



MS-100™ & MS-150™ Installation Guide

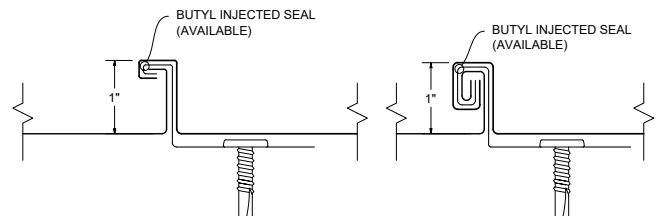
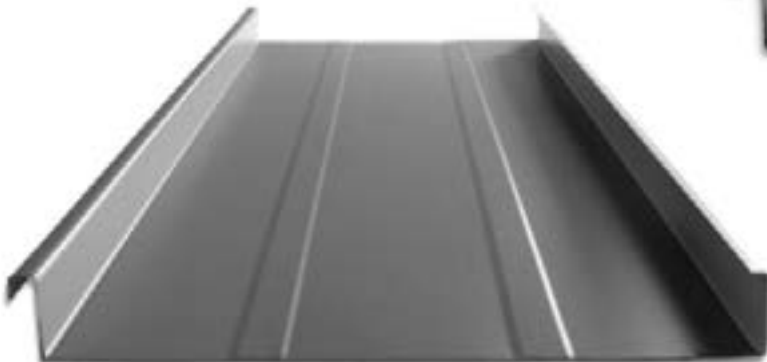
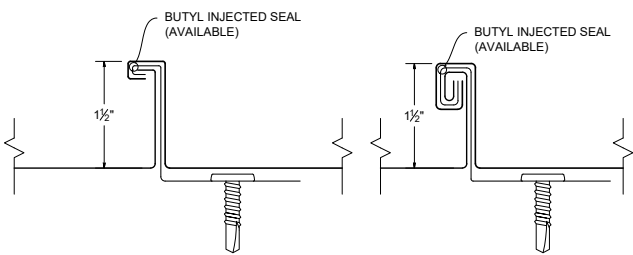

Table of Contents

● Panel Specifications	2-5
● Taylor Delivery Fleet	6
● Delivery & Will Call/Loading	7
● Notes To Designer/Installer	8-10
● Standard Eave	11
● Hook Eave	12
● Gutter/Hook Eave	13
● Standard Ridge	14
● Vented Ridge	15
● End Dam	16
● Valley	17
● Valley – Low Slope	18
● Standard Gable	19
● Alternate Gable	20
● Sidewall	21
● Peak Flashing (R.E.C.)	22
● Vented Peak Flashing (R.E.C.).....	23
● Pitch Change	24
● Endwall	25
● Vented Endwall	26
● Curb Sidewall & Endwall	27
● Curb Back Pan/Cricket	28-31
● Eave to Gable Transition	32-34
● Pipe Penetration – on Pan	35
● Pipe Penetration – on Rib	36-37
● Pipe Penetration – on Plate	38
● Flashing Selection	39-43
● Order Form	44
● Custom Trim	45

13", 17" & 21" coverage options
(other widths inquire)



STRIATIONS

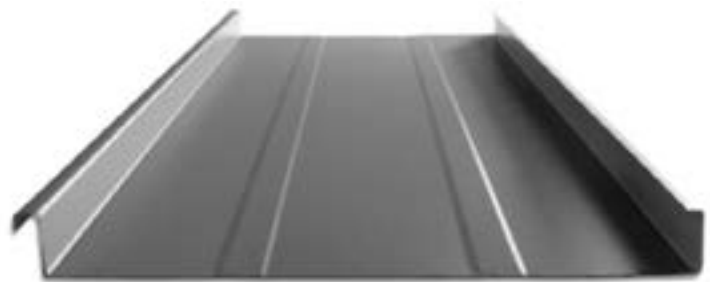

ACCENT RIBS

2 Accent ribs for 13" panels (Salem & Riverside)
3 Accent ribs for 17" & 21" panels
2 Accent ribs for all panels (Sacramento)

90° SEAM DETAIL

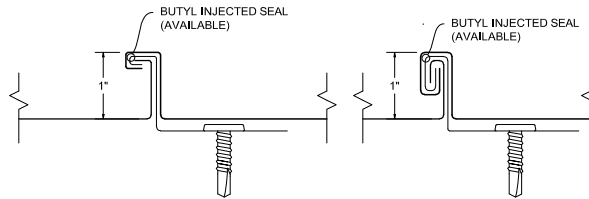

180° SEAM DETAIL

KEY FEATURES

- 13", 17" & 21" coverage options (*other widths inquire*)
- 24 & 22 Tru-Gauge™ and .032" Aluminum
- 16 & 20 oz. Copper (*Please inquire*)
- Zinc Coil (*inquire for thicknesses*)
- Floating clip system: allows for expansion/contraction of panels in longer lengths
- 1" vertical rib
- Factory injected Butyl sealant
- Clip Relief is not standard, available upon request
- Concealed fasteners: fasteners cannot leak
- 1:12 minimum pitch recommended (*For lower pitches, please inquire*)
- Standard panel lengths 3' to 60' - notched
Standard panel lengths 1' to 60' - not notched (*For longer panels, please inquire*)
- Onsite roll forming available
- Panel options: Striations, Accent Ribs, and Flat Pan
- Manufactured in Salem, OR and Riverside, CA

TESTING

-  Code compliance UL Evaluation Report
UL ER #25913-01
- UL Construction No. 575 & 602
- UL 580 Class 90 - Wind Uplift
- UL 790 Class A (ASTM E108) - Fire rated
- UL 2218 Class 4 - Impact (hail) rated
- ASTM A653/A924 - G90 Galvanized
- ASTM A792 - Zinalume/Galvalume AZ-50/55
- ASTM B209 - Aluminum Substrate



The MS-100™ is a mechanically seamed roof that is perfect for high wind areas and snow country. The butyl injected seam prevents water from entering the system, giving you a worry free roof for a lifetime.

MATERIAL SPECIFICATIONS

- 24 Tru-Gauge™ Kynar 500® Painted Steel
- ▲ 22 Tru-Gauge™ Kynar 500® Painted Steel
- ◆ .032" Kynar 500® Painted Aluminum
- 24 Tru-Gauge™ G-90 Galvanized or AZ-50
- 24 and 22 Tru-Gauge™ bare Zincolume® Plus AZ-55 (No finish warranty – 25 yr. perforation warranty)
- G-90 Galvanized or AZ-50
- .032" & .040" Kynar 500® Painted Aluminum (please inquire)
- 24 Tru-Gauge™ Bonderized
- 22 gauge Rusteel Plus™ (A606)
- Custom 20 & 18 Tru-Gauge™ and .050" and .063" Aluminum (please inquire)
- 16 OZ & 20 OZ Real Copper
- Kynar 500® and substrate testing data available (See website)

FINISHES

- 21 Standard Colors, 5 Metallic Colors and 4 Specialized Colors
- Kynar 500® Paint System - the ultimate in exterior durability and color retention
- "Cool" color pigments are specially designed to reflect infrared light, reducing heat gain to dwelling, and conform with ENERGY STAR® criteria
- Superior quality, two coat, 70% resin finish, applied at a 1 mil. thickness
- 40 year residential paint warranty
- 20 and 30 year commercial paint warranty: Contact TMP for warranty specifications
- "Oil Canning" is an inherent characteristic of roof and wall products, and not a defect, which is not a cause for panel rejection

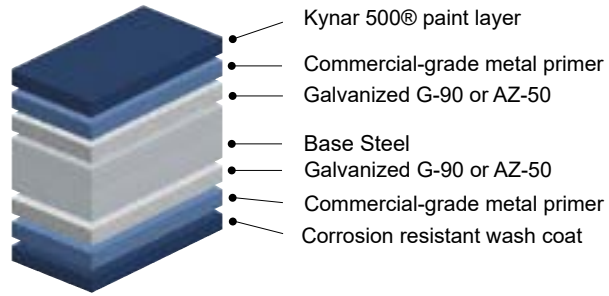

STANDARD COOL KYNAR 500® COLORS

▲ 22 Tru-Gauge™
◆ .032 Aluminum

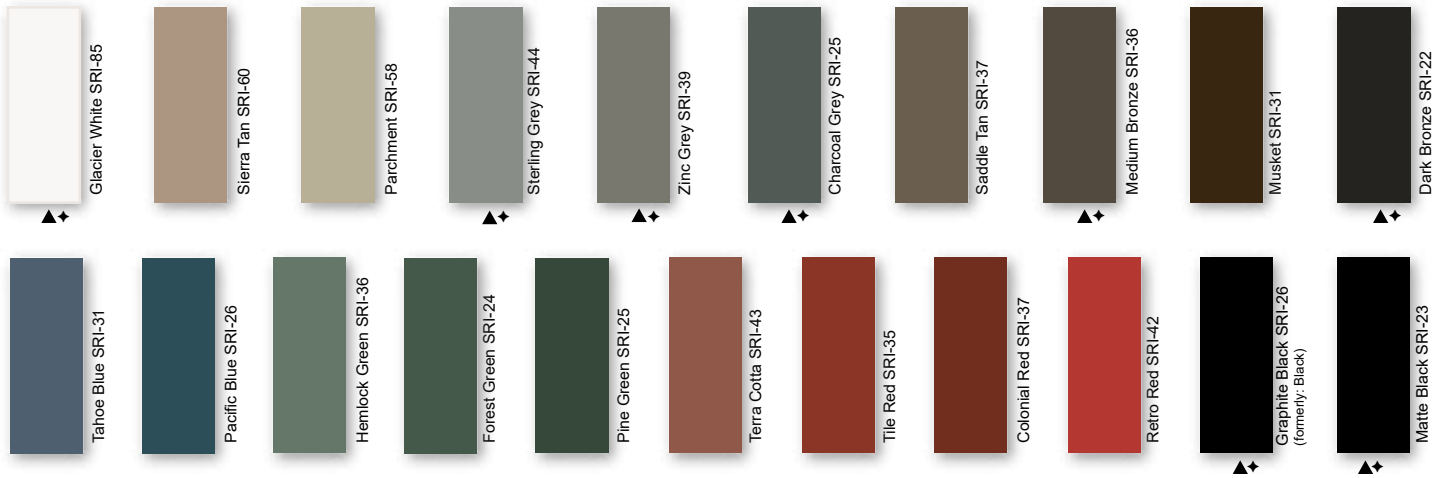

PREMIUM METALLIC COOL KYNAR® COLORS

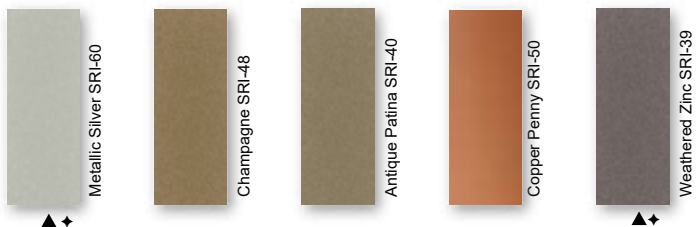

SPECIALIZED MATERIAL

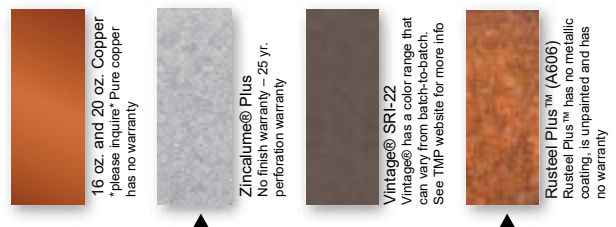

These printed chips provide a close representation of the colors.

Metal samples are available upon request. Coatings are low gloss 10-15% sheen.
SRI = Solar Reflective Index. SRI values listed above are in accordance with ASTM E 1980 and are based on actual testing. ***Oil canning is not a cause for material rejection***



06/24

3

12", 16" & 20" coverage options
(other widths inquire)



STRIATIONS

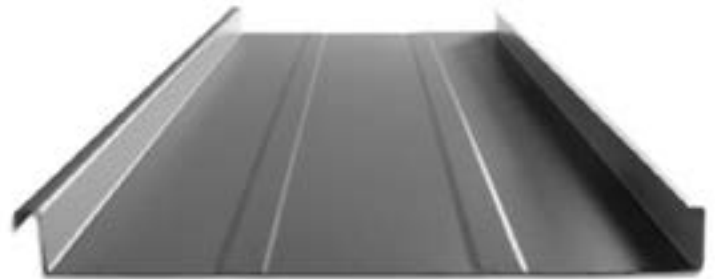

ACCENT RIBS

- 2 Accent ribs for 12" & panels (Salem & Riverside)
- 3 Accent ribs for 16" & 20" panels
- 2 Accent ribs for all panels (Sacramento)



The MS-150™ is a mechanically seamed roof that is perfect for high wind areas and snow country. The butyl injected seam prevents water from entering the system, giving you a worry free roof for a lifetime.

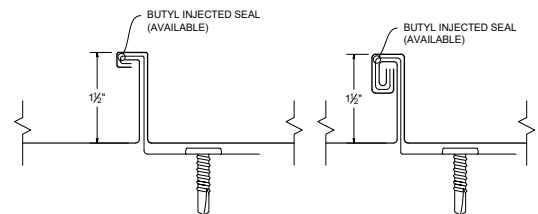



90° SEAM DETAIL

180° SEAM DETAIL

KEY FEATURES

- 12", 16" & 20" coverage options (*other widths inquire*)
- 24 & 22 Tru-Gauge™ and .032" Aluminum
- 16 & 20 oz. Copper (*Please inquire*)
- Zinc Coil (*inquire for thicknesses*)
- Floating clip system: allows for expansion/contraction of panels in longer lengths
- 1-1/2" vertical rib
- Factory injected Butyl sealant
- Clip Relief is not standard, available upon request
- Concealed fasteners: fasteners cannot leak
- 1:12 minimum pitch recommended (*For lower pitches, please inquire*)
- Standard panel lengths 3' to 60' - notched
Standard panel lengths 1' to 60' - not notched (*For longer panels, please inquire*)
- Onsite roll forming available
- Panel options: Striations, Accent Ribs, and Flat Pan
- OverEZee retro-fit systems available
- Weather tightness warranty available: (*Contact TMP representative for details*)

TESTING

-  ICC #5046 with CBC-CRC Supplement
-  Code compliance UL Evaluation Report UL ER #25913-01
- UL Construction No. 554, 588, 603, 604, 605
- UL 580 Class 90 - Wind Uplift
- UL 790 Class A (ASTM E108) - Fire rated
- UL 2218 Class 4 - Impact (hail) rated
- ASTM E1680 - Air Infiltration (roof)
- ASTM E283 Air Infiltration(wall)
- ASTM E1646 - Water Infiltration (roof)
- ASTM E331 Water Infiltration(wall)
- ASTM A653/A924 - G90 Galvanized
- ASTM A792 - Zincalume/Galvalume AZ-50/55
- ASTM B209 - Aluminum Substrate
- ASTM E2140 Standard Test Method for Water Penetration (full immersion)

MATERIAL SPECIFICATIONS

- 24 Tru-Gauge™ Kynar 500® Painted Steel
- ▲ 22 Tru-Gauge™ Kynar 500® Painted Steel
- ◆ .032" Kynar 500® Painted Aluminum
- 24 Tru-Gauge™ G-90 Galvanized or AZ-50
- 24 and 22 Tru-Gauge™ bare Zincolume® Plus AZ-55 (No finish warranty – 25 yr. perforation warranty)
- G-90 Galvanized or AZ-50
- .032" & .040" Kynar 500® Painted Aluminum (please inquire)
- 24 Tru-Gauge™ Bonderized
- 22 gauge Rusteel Plus™ (A606)
- Custom 20 & 18 Tru-Gauge™ and .050" and .063" Aluminum (please inquire)
- 16 OZ & 20 OZ Real Copper
- Kynar 500® and substrate testing data available (See website)

FINISHES

- 21 Standard Colors, 5 Metallic Colors and 4 Specialized Colors
- Kynar 500® Paint System - the ultimate in exterior durability and color retention
- "Cool" color pigments are specially designed to reflect infrared light, reducing heat gain to dwelling, and conform with ENERGY STAR® criteria
- Superior quality, two coat, 70% resin finish, applied at a 1 mil. thickness
- 40 year residential paint warranty
- 20 and 30 year commercial paint warranty: Contact TMP for warranty specifications
- "Oil Canning" is an inherent characteristic of roof and wall products, and not a defect, which is not a cause for panel rejection

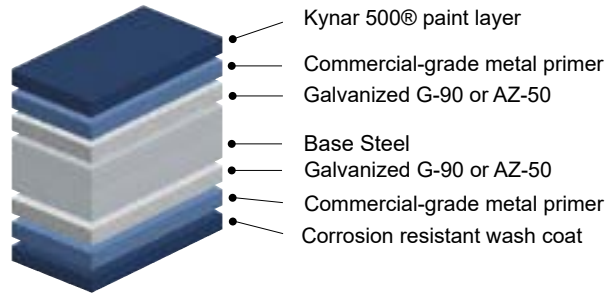

STANDARD COOL KYNAR 500® COLORS

▲ 22 Tru-Gauge™
◆ .032 Aluminum

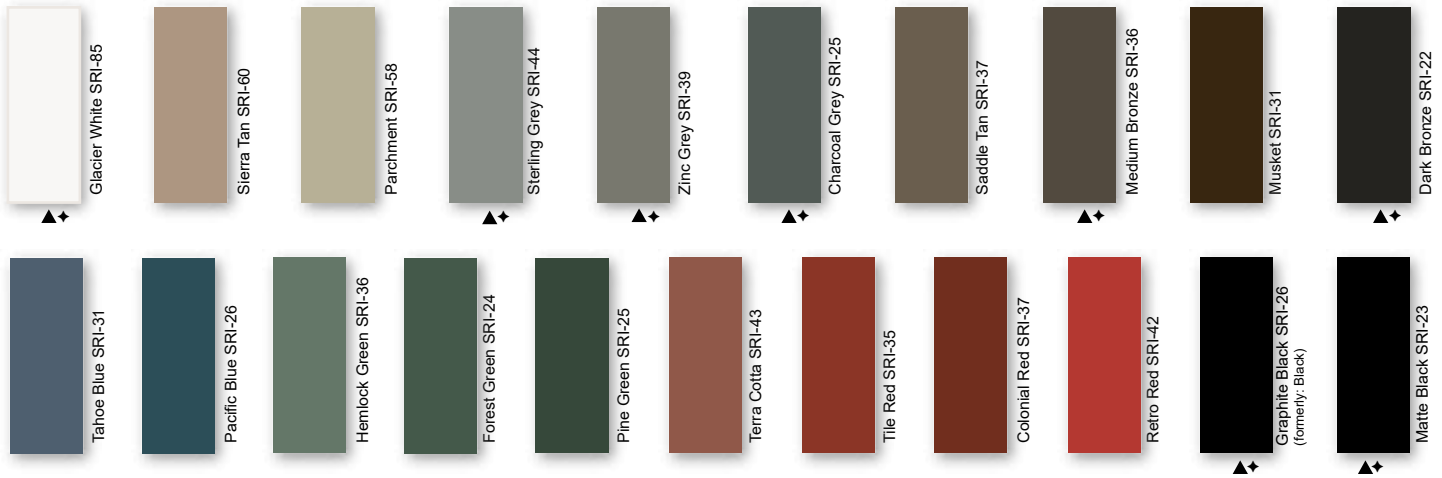

PREMIUM METALLIC COOL KYNAR® COLORS

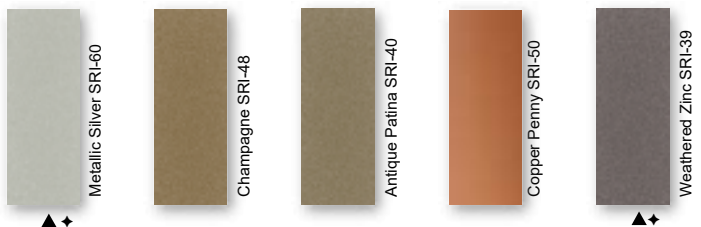

SPECIALIZED MATERIAL

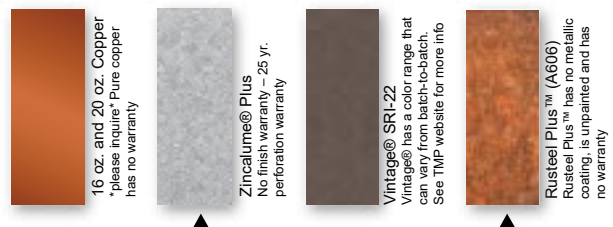

These printed chips provide a close representation of the colors.

Metal samples are available upon request. Coatings are low gloss 10-15% sheen.
SRI = Solar Reflective Index. SRI values listed above are in accordance with ASTM E 1980 and are based on actual testing. ***Oil canning is not a cause for material rejection***



06/24

5

Taylor Delivery Fleet



Delivery Fleet

Taylor Metal Products prides itself with quick lead times delivered with our fleet of semi trucks. Our fleet of trucks are owned and operated by TMP. All of our drivers are Taylor Metal Products employees, so when your truck rolls in to deliver, you are dealing with Taylor Metal Products.

Expect consistent and exceptional service with short lead times. The inhouse fleet allows for efficient and cost-effective delivery.



Mounted on the rear of our semitrailer, the truck-mounted "piggy-back" forklift will accompany you right to your place of use, opening up unprecedented possibilities in terms of transportation. It can travel sideways, carrying panels up to 40' long, allowing delivery in locations that would typically be considered impossible to reach.

Save time and effort while avoiding potential loading and transport issues; have experienced TMP personnel deliver and unload your order.



Delivery

We will make every attempt to deliver material to the desired location. We may be unable to gain access on tight corners or steep terrain. If the site is deemed inaccessible by our driver, the customer may choose an alternate delivery site within a reasonable proximity. If we are unable to make the alternate delivery, additional charges may be assessed.

The customer is responsible for:

- Determining adequate access for delivery ahead of time.
- Meeting the delivery at the agreed upon time.
- Providing adequate resources (1-4 people as needed) for off loading materials.
- A charge of \$100 per hour may be added for deliveries that go beyond their allotted time
- Check the shipment at the time of delivery.
- Verify material quantities against the shipping/packing list.
- Note any damage or discrepancies upon the paper work at the time of delivery and notify Taylor Metal Products within 48 hours of delivery.

Delivery times are usually scheduled one day in advance. Taylor Metal Products will make every effort to make the delivery at the scheduled time. Please be aware that there may be conditions beyond our control such as traffic, mechanical failures, road closures, etc. which may affect our schedule.

Will Call/Loading

Flatbed trailers and trucks are best suited to transport metal roofing materials. These can be loaded from the side with a forklift and tied down in a safe and secure manner.

We are not able to load materials onto vehicles and/or trailers which are not suitable or may be hazardous to load. Please be aware that if we find a vehicle to be inappropriate, we reserve the right to refuse to load your order.

Unacceptable examples include: boat trailers, vans, buses, motor homes, campers and box trailers. Pickup racks which do not have sufficient supports for the weight or are not long enough to support bundles are also unacceptable.

Taylor Metal Products is not responsible to tie down loads nor do we provide any tie down materials. Please bring tie downs to secure your load (string or twine are **not** acceptable for this purpose).

Consider having your order delivered on one of our trucks with a piggy back forklift.



Notes to Designer/Installer

Taylor Metal Products is providing the following details as an aid in design. The details in this guide are not inclusive to all design situations. The designer/installer is responsible for modifications and should take into consideration all aspects of the project including climate conditions, such as, snow and wind, as well as, building code requirements, building design, building usage and maintenance requirements.

Installation should be performed only by qualified installers familiar with metal roofing systems and industry standards. For details not shown in this guide, refer to the Sheet Metal and Air Conditioning Contractors National Association (SMACNA) architectural sheet metal manual for proper design. For manufacturer's weather tightness warranties – all details must be preapproved by Taylor Metal Products technical representative.

The Standard gauge for all products in this guide is 24 gauge and the standard finish is Kynar 500®. We recommend specifying all flashings be the same gauge, color, and finish as the panels to ensure long-term durability and color match.

Substrates

Details in the manual are all shown over solid substrate. **MS-100™/MS-150™** can be used over spaced purlins. For solid substrate, **Taylor Metal Products** recommends 15/32" plywood or 22 ga. metal decking. Contact a TMP representative with questions about panel attachment to varying substrates.

Underlayment

For roofs with pitches below 3:12, High Temp Ice and Water shield underlayment must be installed across the entire surface (projects with manufacturer's weathertightness warranties require the TMP private label product). For pitches steeper than (or equal to) 3:12, High Temp Ice and Water is necessary at all perimeter locations, eave, ridge, valley, hips, sidewall, endwall, prow and penetrations. The remaining of the roof's field areas can then be covered with approved synthetic felt. If local codes or specifications require a Class A fire rated assembly, Polystick XFR or Titanium FR (both products are distributed by TMP) must be installed over the entire roof with combustible decks.

Follow manufactures instructions carefully for all underlayment installation.

Drag Load Requirements

All panels must be pinned at one end to resist the drag load caused by snow loads, live loads, and the weight of the panel. Drag load is a function of roof slope, actual load and length of panels. Contact **Taylor Metal Products** for specific drag load requirements.

Ventilation/Insulation

It is the responsibility of the designer to determine the material types needed to control condensation and to insulate and ventilate the roof system. Applications over rigid insulation may require blocking for solid attachment and framing the perimeter for installation of perimeter flashings.

Oil Canning

Flat metal surfaces will display waviness commonly referred to as “oil canning.” Oil canning is caused by a variety of conditions. Steel mill tolerances, variations in or uneven substrates and roofing underlayments. Oil canning is a characteristic of metal roofing, not a defect and is not a cause for rejection. **Taylor Metal Products** offers **MS100™/MS150™** with striations or accent ribs to help minimize oil canning.

Thermal Movement

The Panels and the flashings must be allowed to expand and contract, especially with longer length panels. The panel may need to have a slight gap where the panel hooks the offset cleat to allow for thermal movement of the panels.

Snow Design

The following details do not address all conditions for snow environments. Consult with the designers, engineers, and others for acceptable details to accommodate your project and climate conditions. When possible gutters, valleys, pitch changes or other penetrations should be minimized in snow areas.

All roof penetrations should be located as close to the ridge or “pin point” top of roof. Snow country requires special designs for valleys to accommodate accumulation of snow and ice from uphill panels. Roof design should be considered in snow areas. Roof design should help resist the melting and freezing of snow and ice.

A fit for purpose roof design has the greatest impact on maintaining a damage free roof system in snow areas. Please contact a **Taylor Metal Products** representative for assistance in detail designs and appropriate panel selection for specific climate and building conditions.

MS-100™ / MS-150™

Flashing and Details Guide

Handling / Storage & Safety

Handle materials with care when off-loading or moving materials to avoid damage to panels or flashings. Long panels may require two or more pick-up points, properly spaced to avoid damaging panels. Plan ahead; contact **Taylor Metal Products** for recommendations on handling/hoisting long panels.

Store the panels, flashings and accessories in a dry, well ventilated area, off the ground. If covering, allow ventilation around panels. Elevate one end of bundle to allow drainage of wet materials.

Wear clean, soft-soled shoes when walking on roofing panels to avoid damage to the painted finish.

Take care that sand, gravel, dirt, etc. sticking to your shoes is not carried onto the roof, scratching or otherwise damaging the finish on the roofing material. Walking on asphalt impregnated felt paper, especially on a hot day, can cause the asphalt to stick to your shoes and be tracked on to the roofing material.

Take care when painting to avoid getting over spray on the roofing material. Remember that wind can carry paint particles some distance. Over spray can cause the finish of the roofing material to look dull and may void your warranty.

Secure materials, especially when leaving the site, on the ground or roof to prevent winds from moving the materials. Wind-blown materials may cause damage to the material, property or persons.

Always use proper safety equipment and attire to minimize risk of cuts or other injuries.

Do not walk on panels that have not been completely installed.

Do not walk on major ribs of panels.

Metal roofs that are wet or dusty can be extremely slippery. Wear soft soled shoes and a safety harness to minimize risk of falling.

Avoid installing metal panels in windy conditions.

Safety considerations are the responsibility of the installer and his crew. Be sure to **use common sense** and generally accepted safety practices when installing roofing materials.

STANDARD EAVE DETAIL

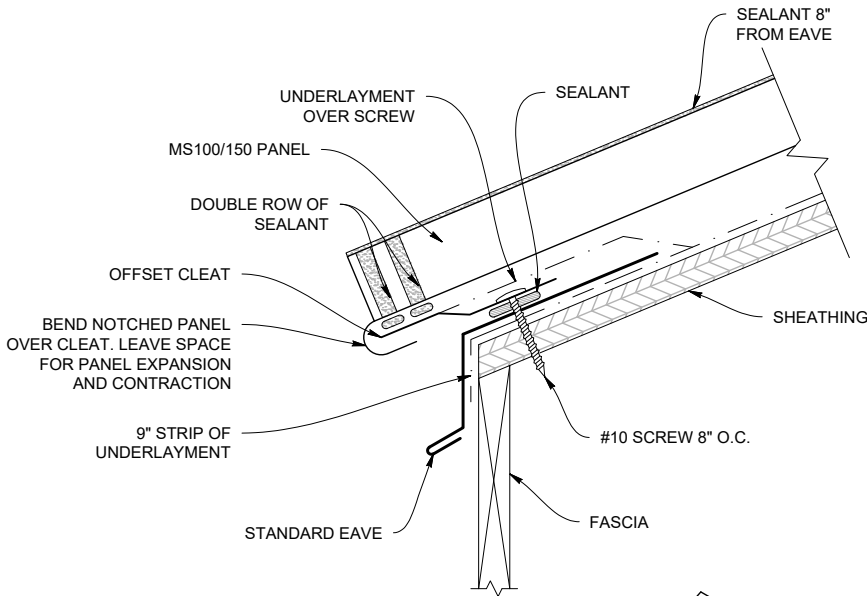

STANDARD EAVE (MS150ES / MS100ES)

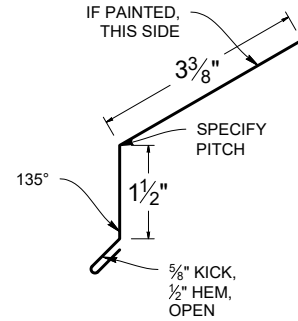

OFFSET CLEAT (MS150OC / MS100OC)

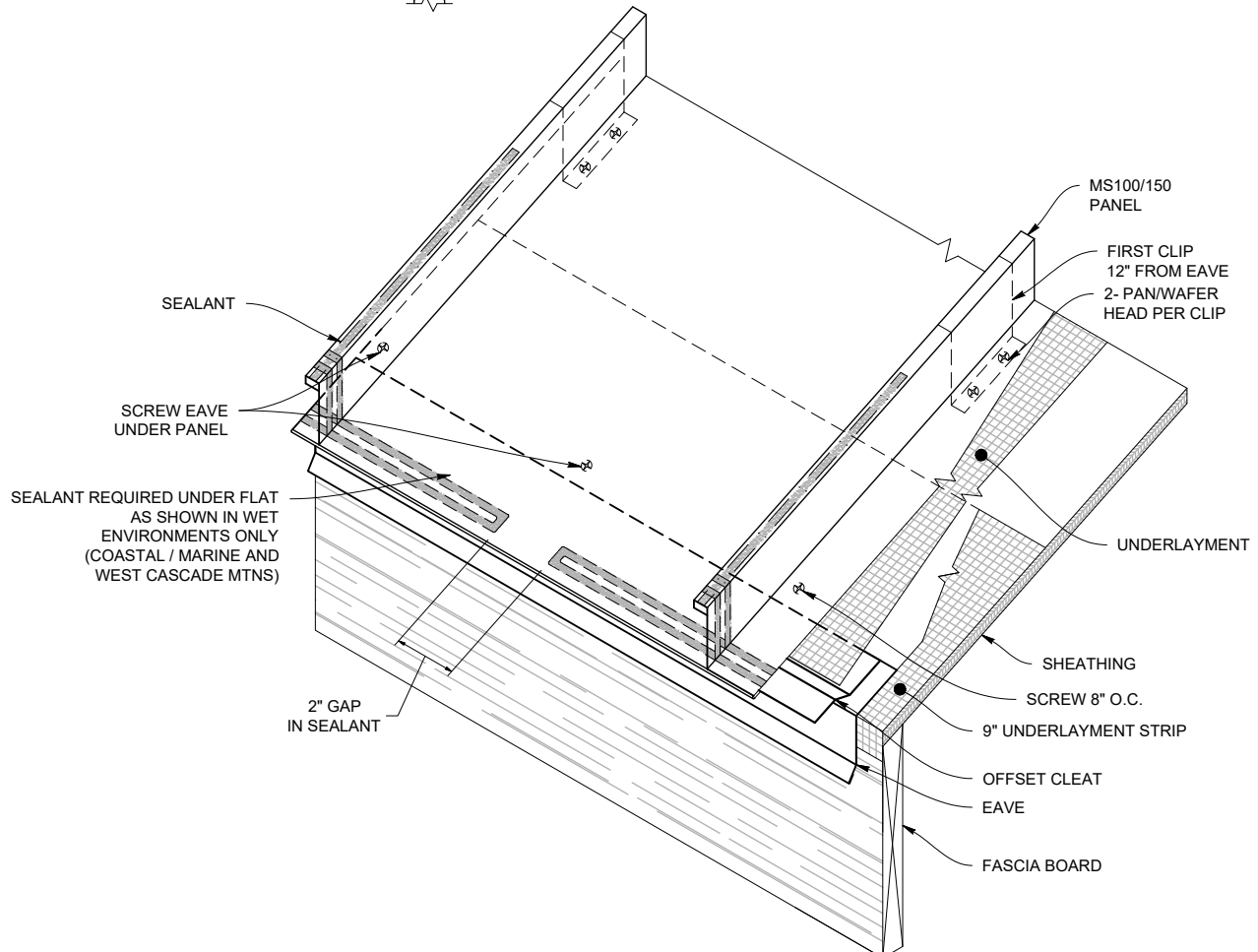
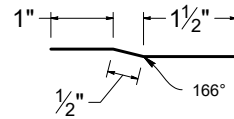

Note: All screws must be fastened into solid substrate.
Flashing must be lapped 4" with 3 rows of gunnable sealant.

Hook Eave

HOOK EAVE DETAIL

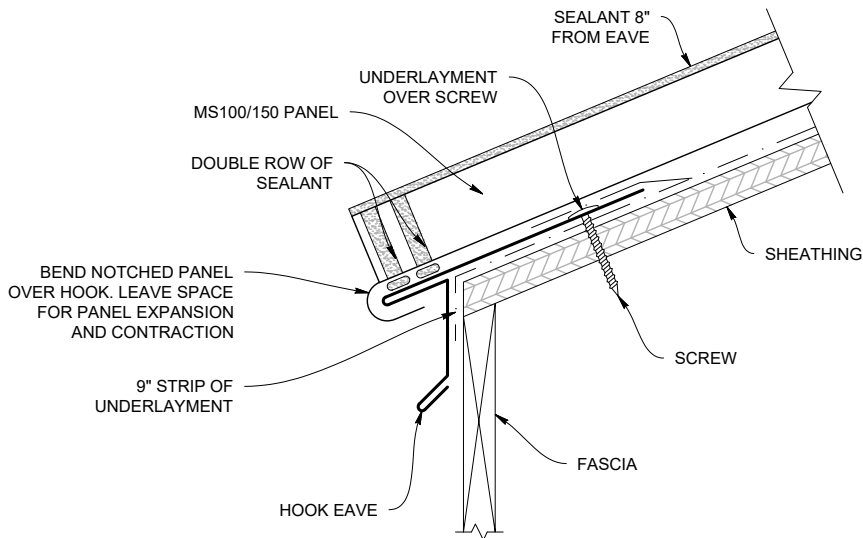

HOOK EAVE (MS150EH / MS100EH)

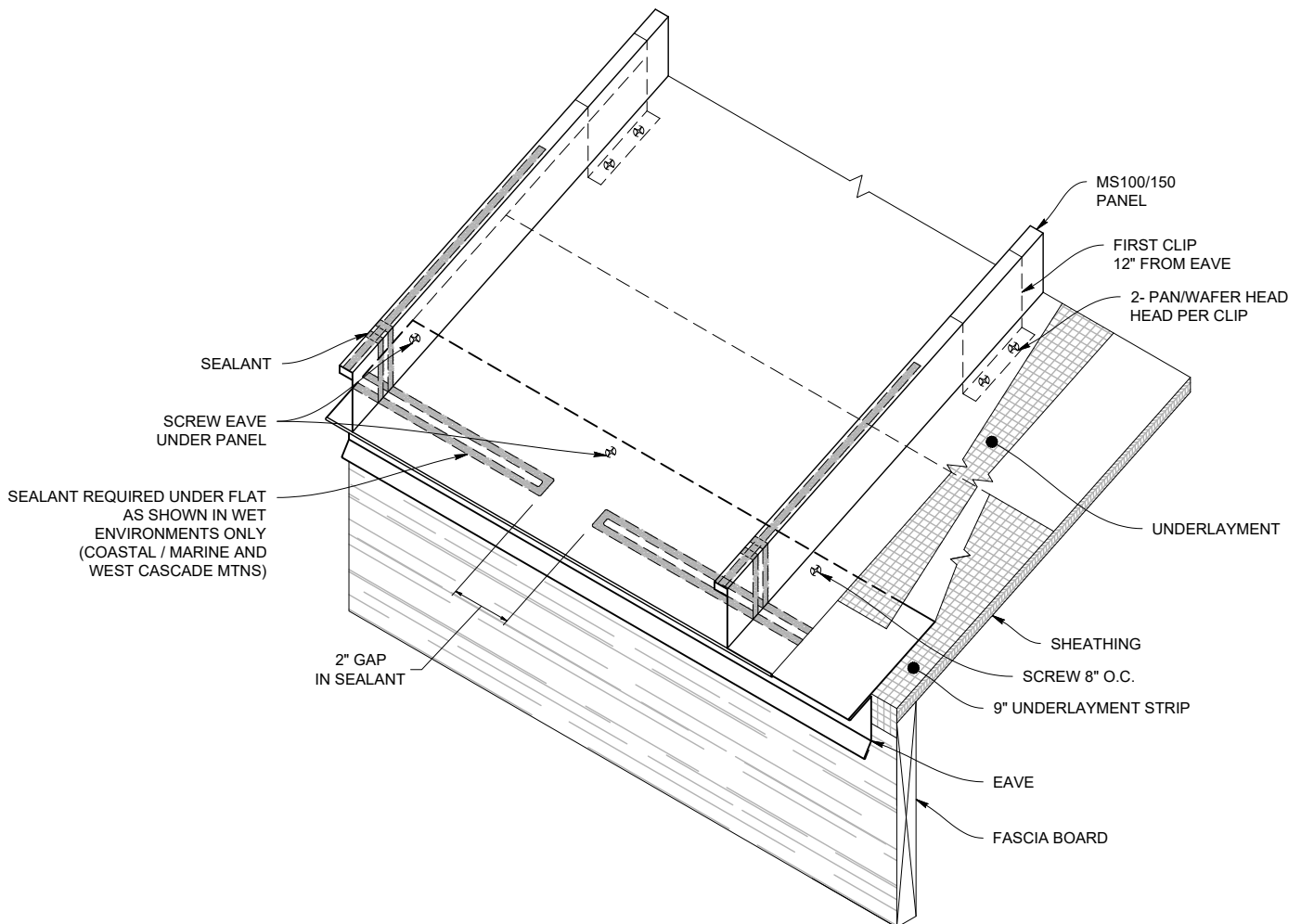
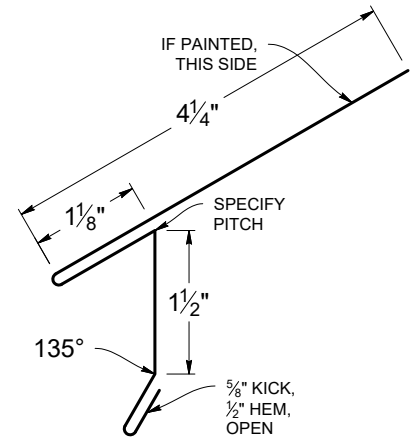

HOOK EAVE WITH GUTTER DETAIL

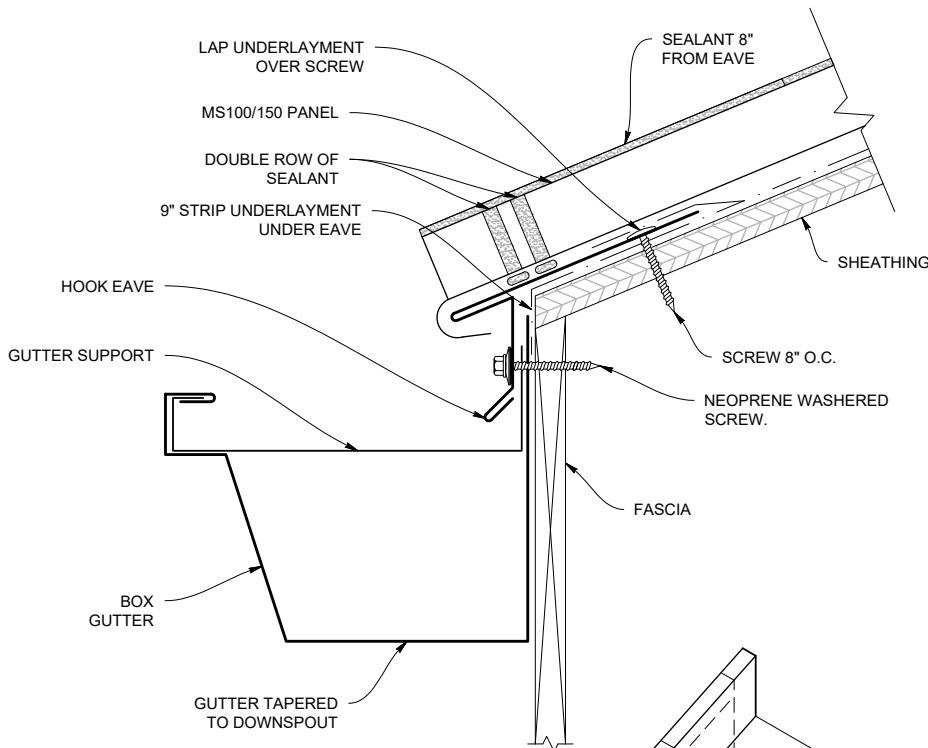

BOX GUTTER (MS150BG / MS100BG)

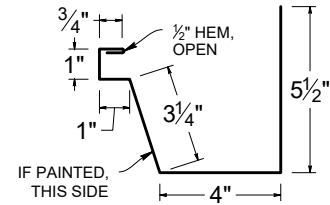

HOOK EAVE (MS150EH / MS100EH)

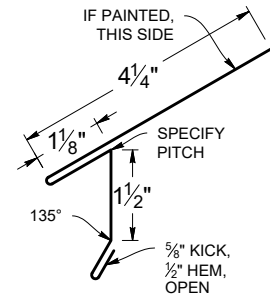

BOX GUTTER HANGER (AGH6)

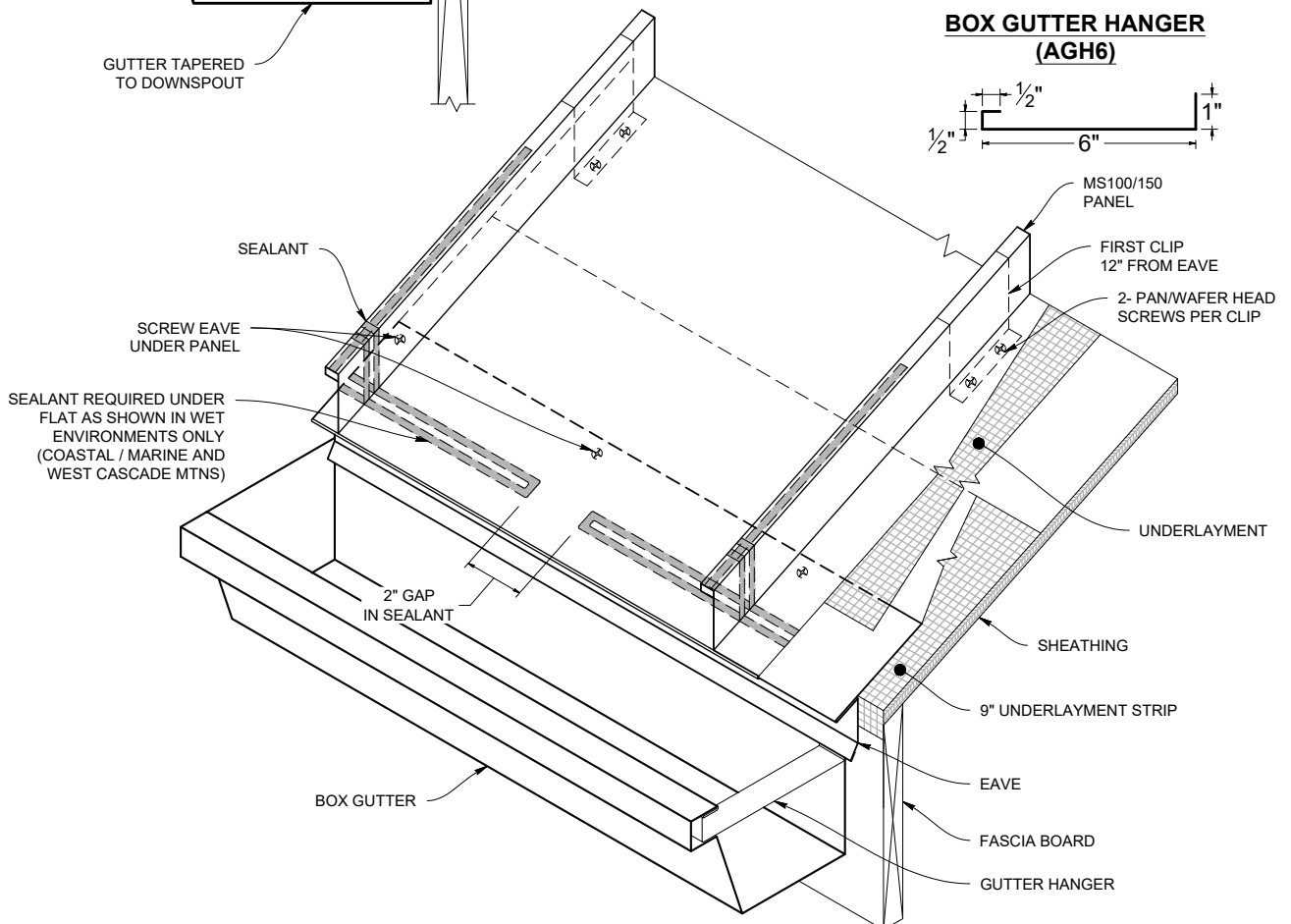
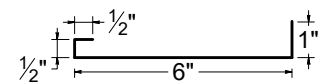

Note: All screws must be fastened into solid substrate. Flashing must be lapped 4" with 3 rows of gunnable sealant.

Standard Ridge

STANDARD RIDGE DETAIL

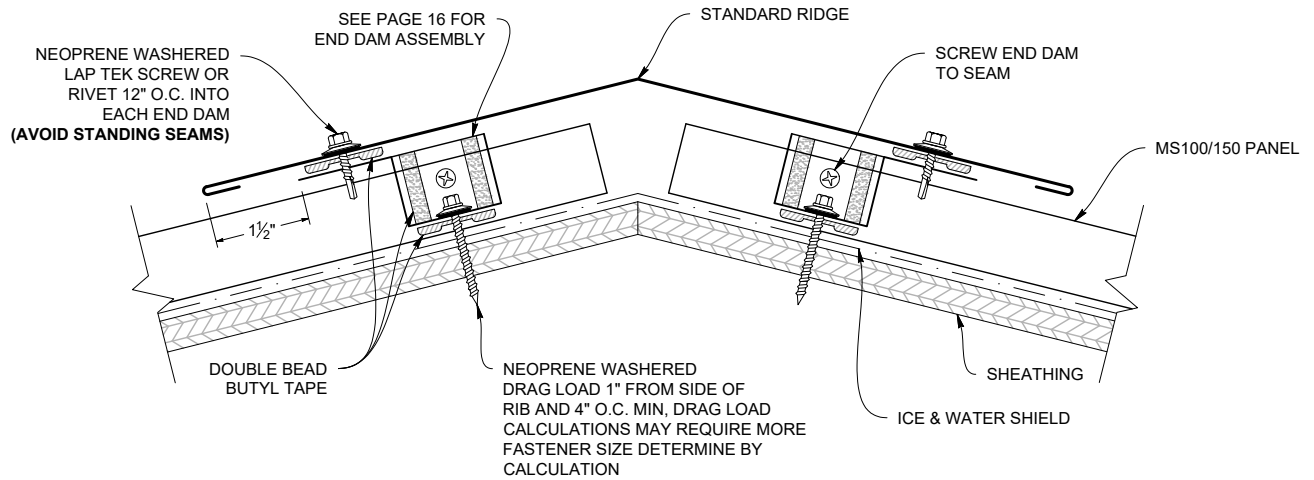

STANDARD RIDGE (MS150RS / MS100RS)

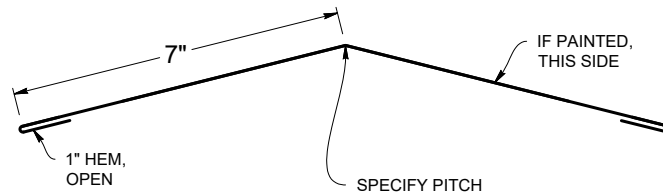

STANDARD RIDGE LAP

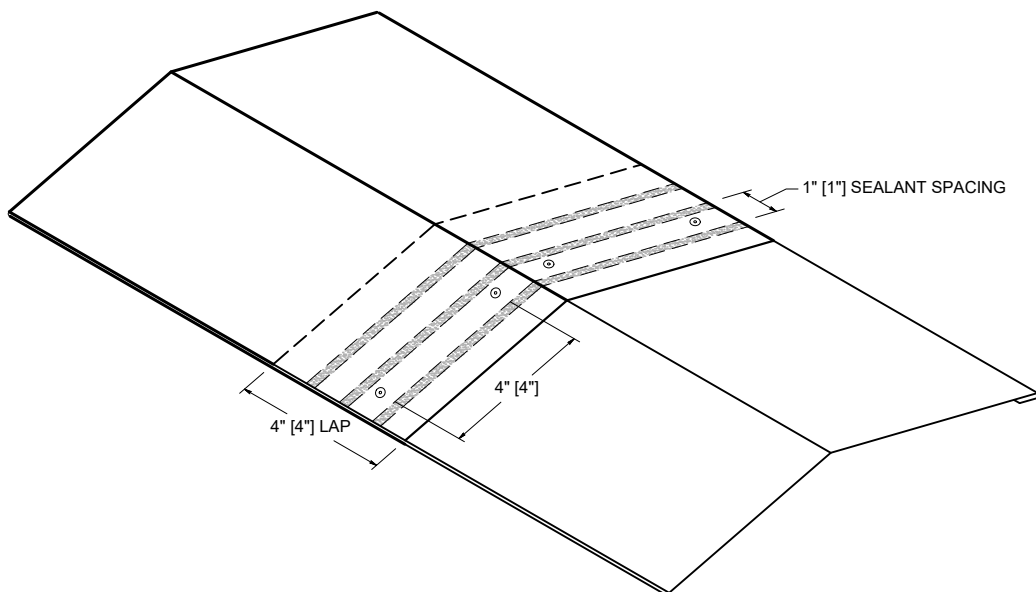

Note: All screws must be fastened into solid substrate.
Flashing must be lapped 4" with 3 rows of gunnable sealant.

WT VENTED RIDGE DETAIL

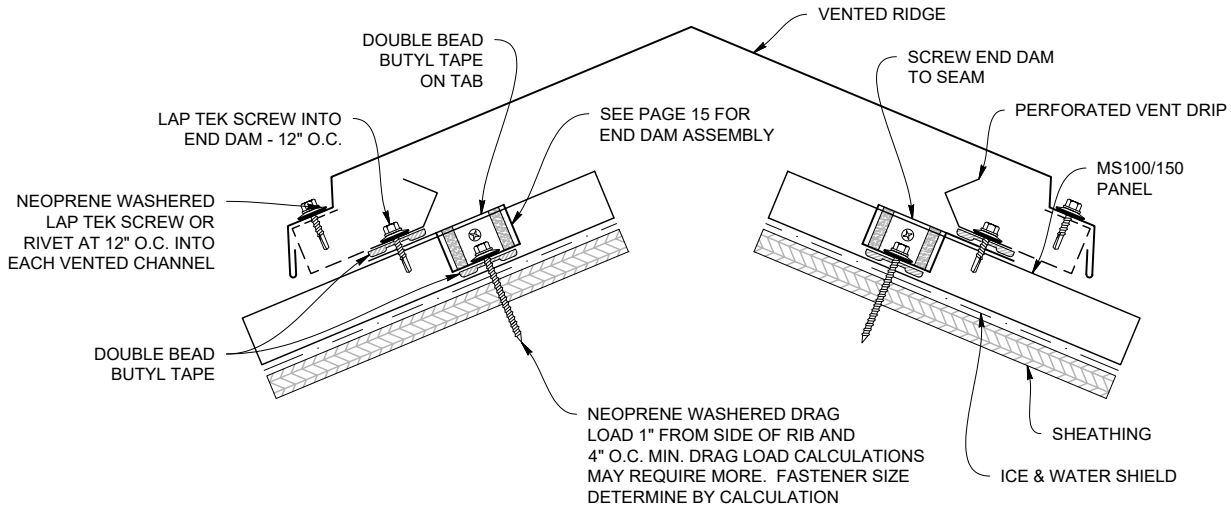

WT RIDGE FULL VENTED MS150WTRFV / MS100WTRFV

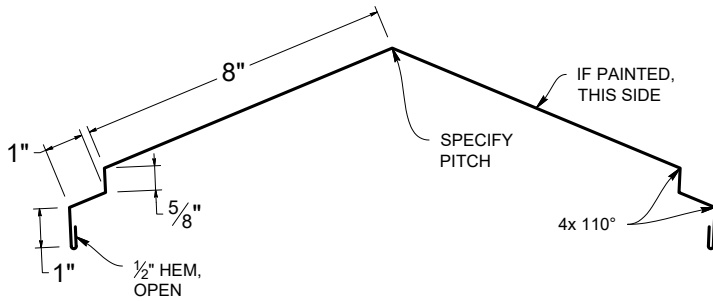

PERFORATED VENT DRIP MS150PVD / MS100PVD

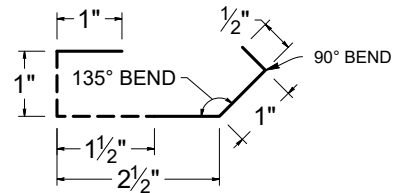

VENTED RIDGE LAP

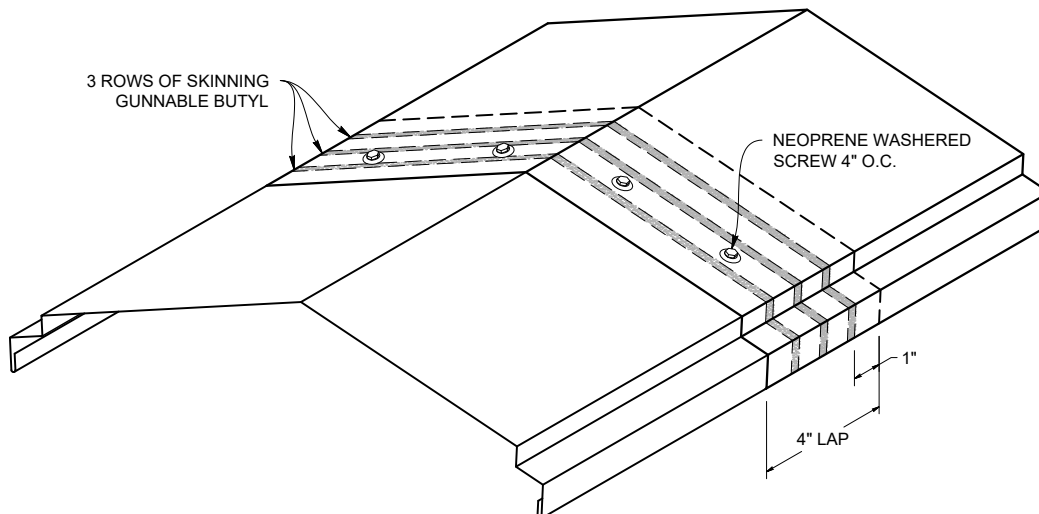

Note: All screws must be fastened into solid substrate.
Flashing must be lapped 4" with 3 rows of gunnable sealant.

End Dam

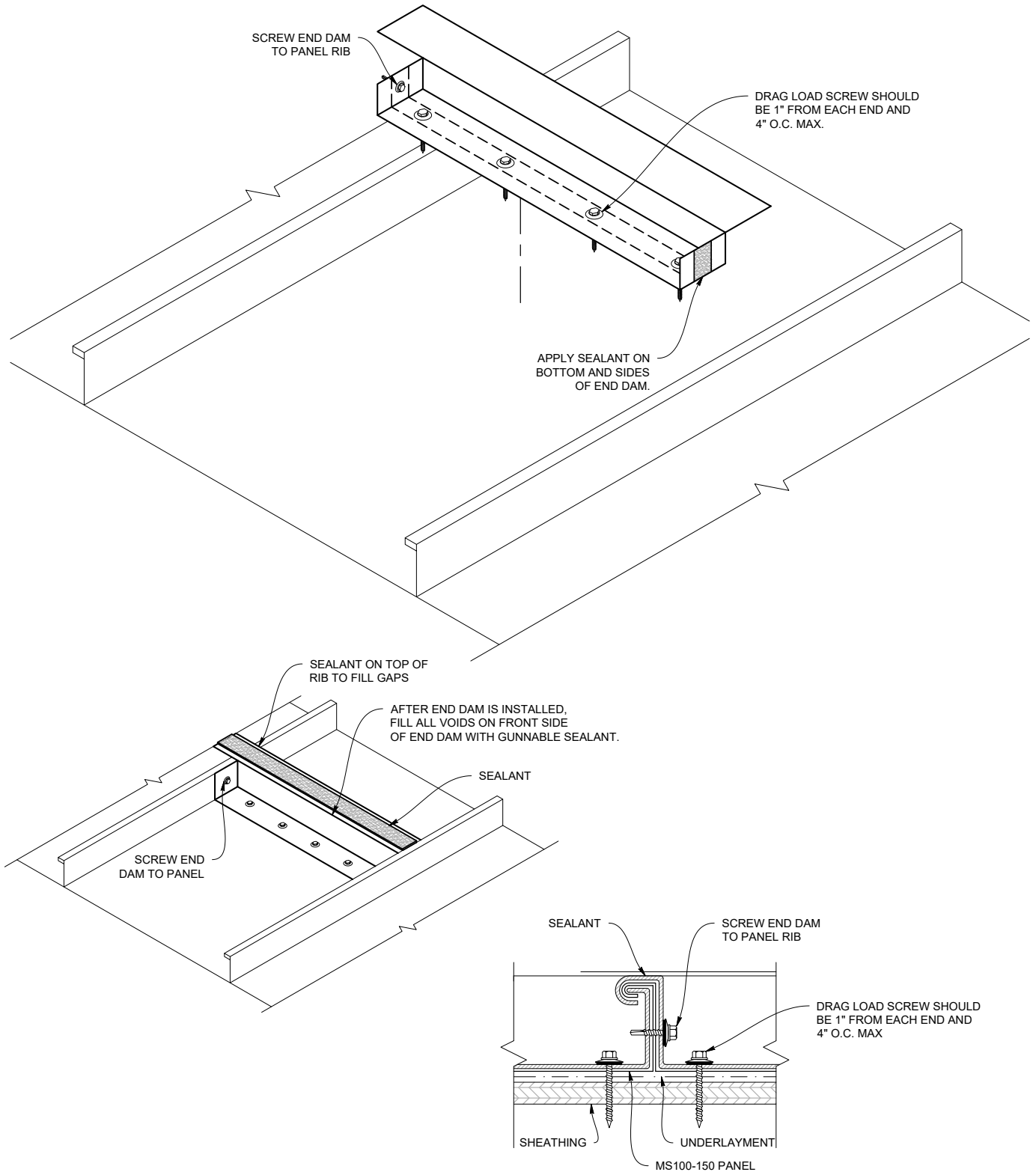

VALLEY 24" FLASHING (MS150VF / MS100VF)

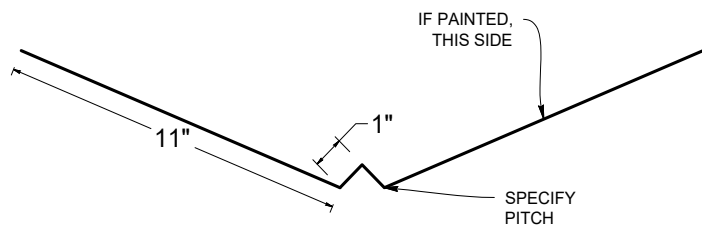

OFFSET CLEAT (MS150OC / MS100OC)

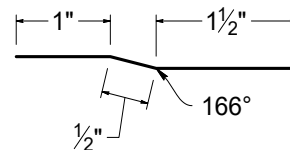

VALLEY 24" DETAIL (3:12 Or Greater Pitch)

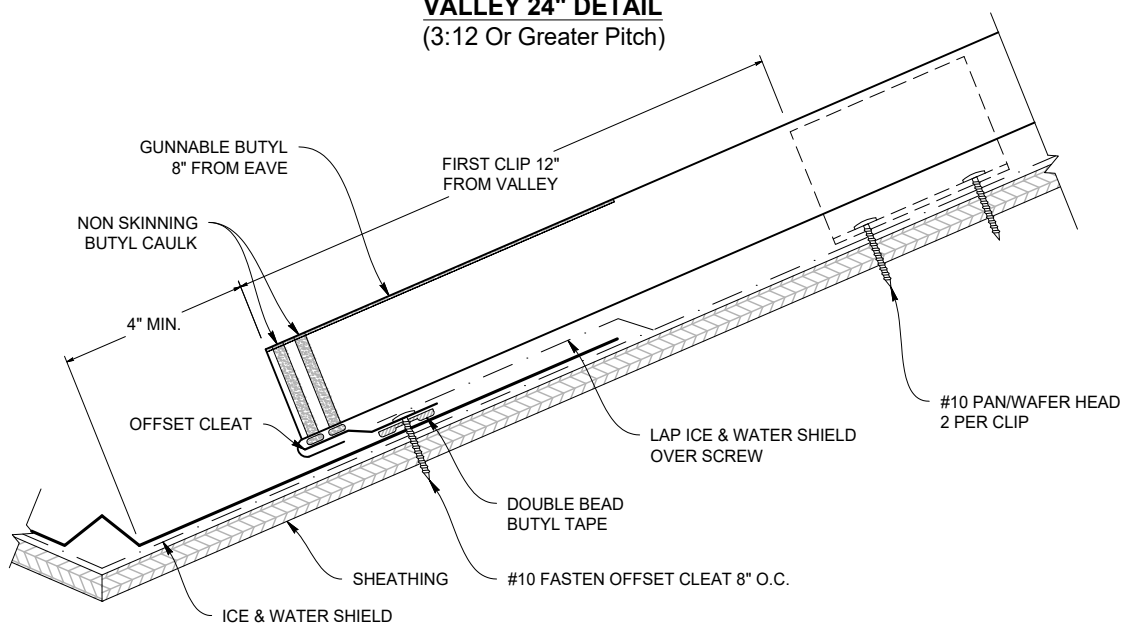

VALLEY LAP (3:12 Or Greater Pitch)

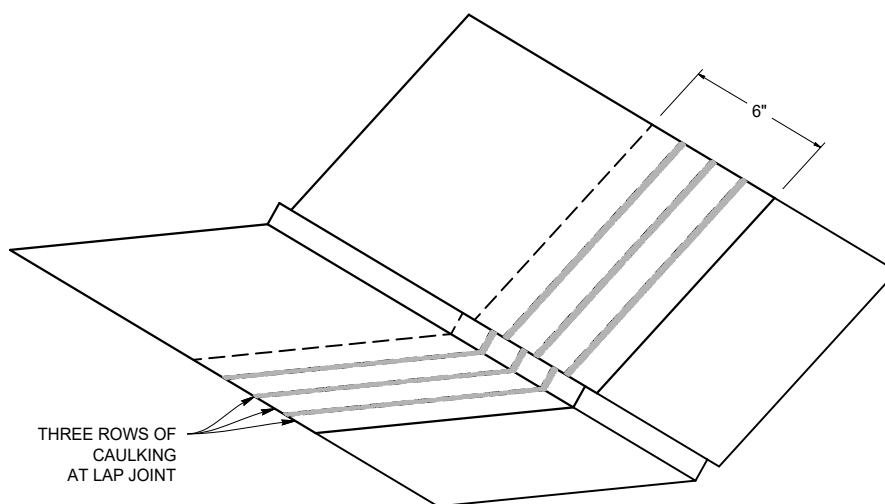

Note: All screws must be fastened into solid substrate.
Flashing must be lapped 4" with 3 rows of gunnable sealant.

Valley Flashing - Low Slope

Slope Less than 3:12



LOW SLOPE VALLEY DETAIL (Less Than 3:12 Pitch)

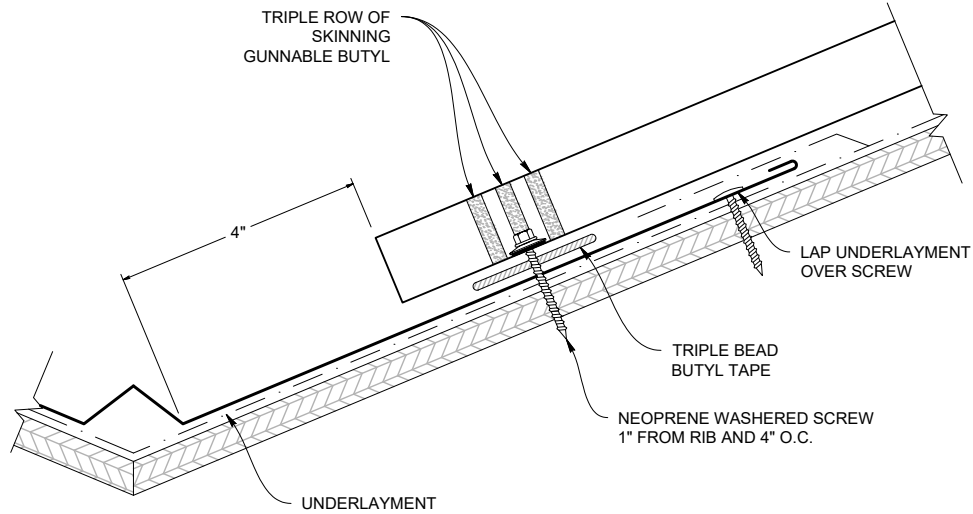

VALLEY FLASHING (MS150VF / MS100VF)

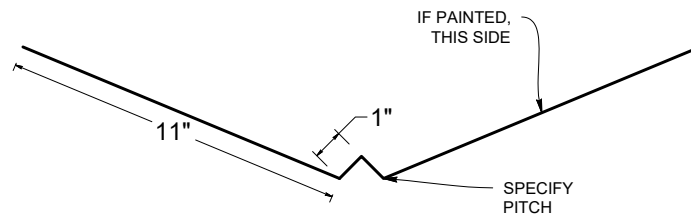

LOW SLOPE VALLEY LAP (Less Than 3:12 Pitch)

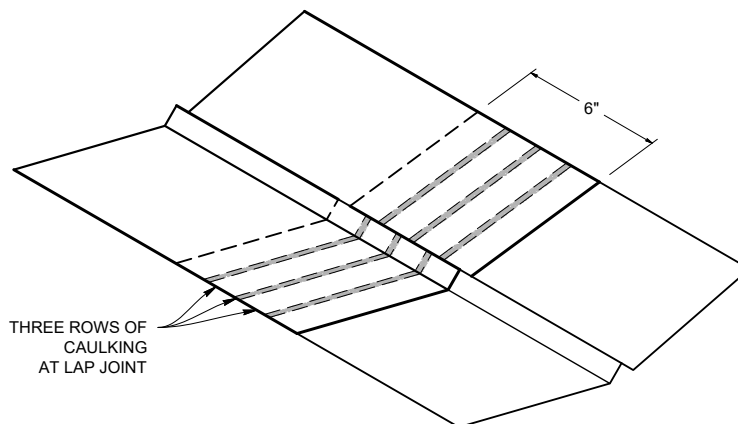

Note: All screws must be fastened into solid substrate.
Flashing must be lapped 4" with 3 rows of gunnable sealant.

STANDARD GABLE DETAIL

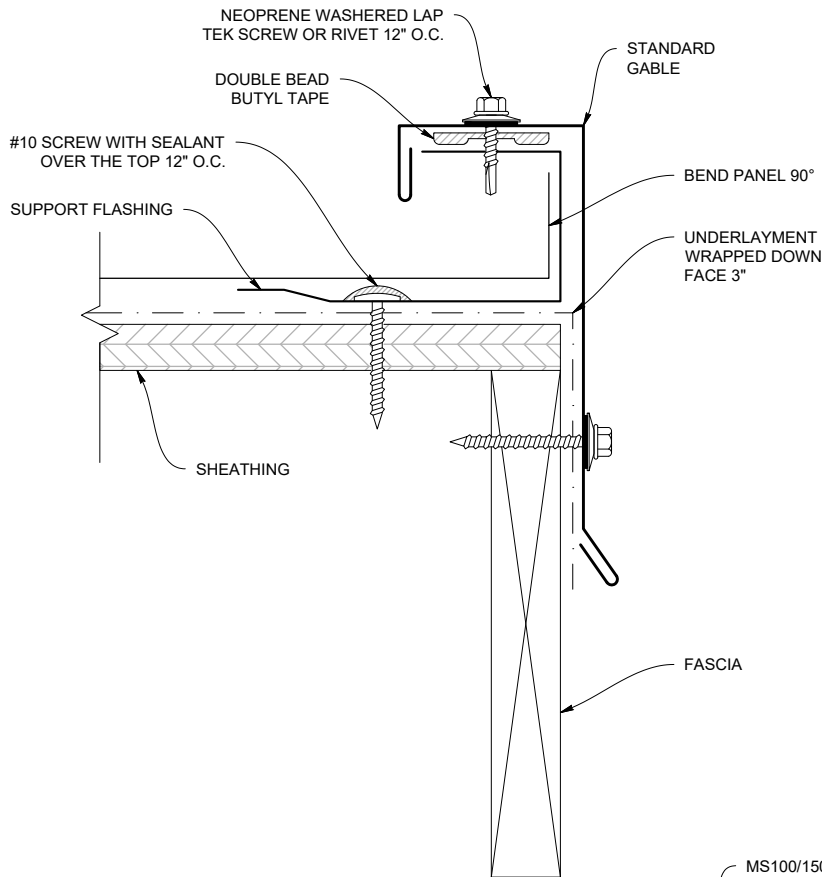

STANDARD GABLE (MS150GS / MS100GS)

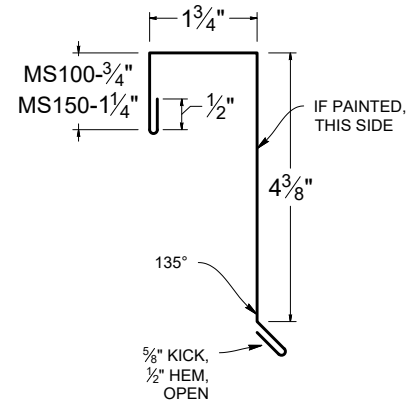

SUPPORT FLASHING (MS150SF / MS100SF)

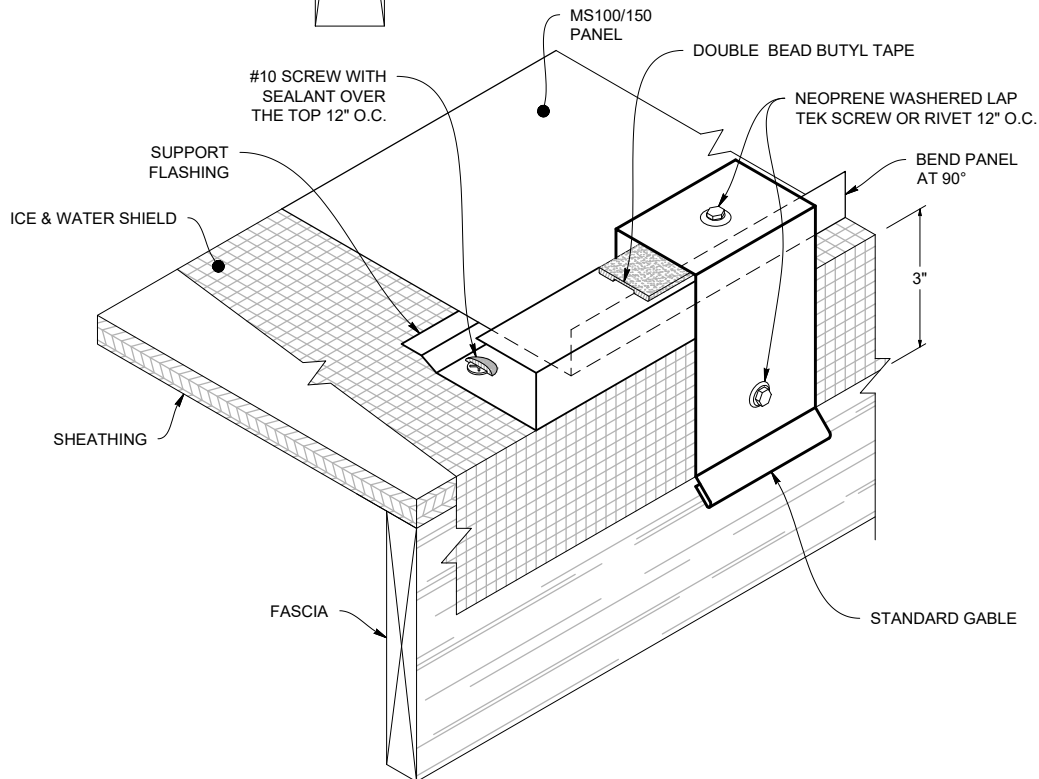
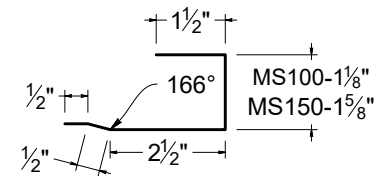

Note: All screws must be fastened into solid substrate.
Flashing must be lapped 4" with 3 rows of gunnable sealant.

Alternate Gable

SUPPORT FLASHING (MS100SF / MS150SF)

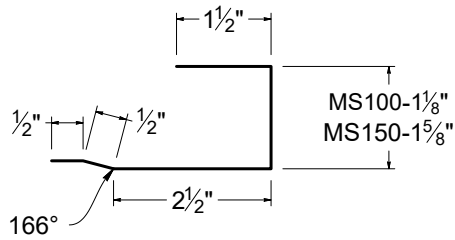

ALTERNATE GABLE (MS200AT)

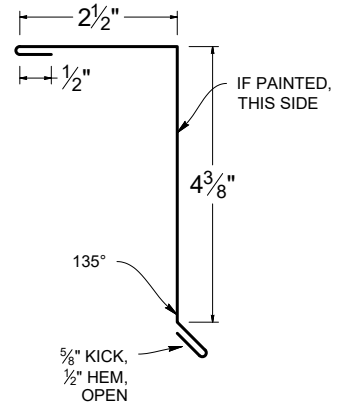

ALTERNATE GABLE DETAIL

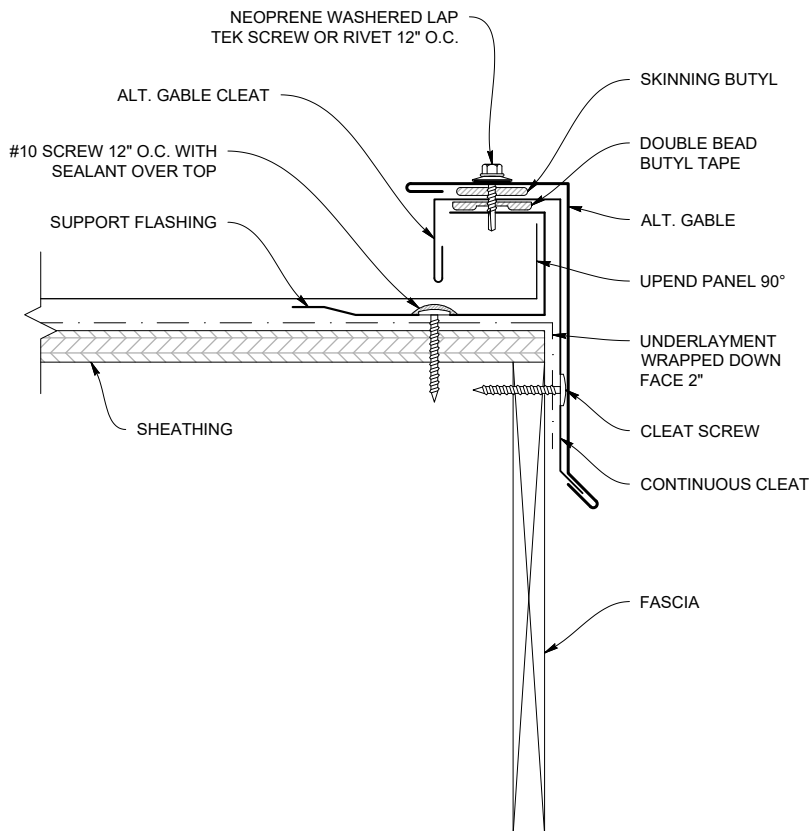

ALTERNATE GABLE CLEAT (MS100AGC / MS150AGC)

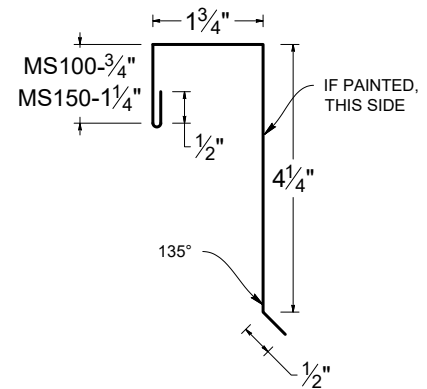

Note: All screws must be fastened into solid substrate.
Flashing must be lapped 4" with 3 rows of gunnable sealant.

SIDEWALL DETAIL

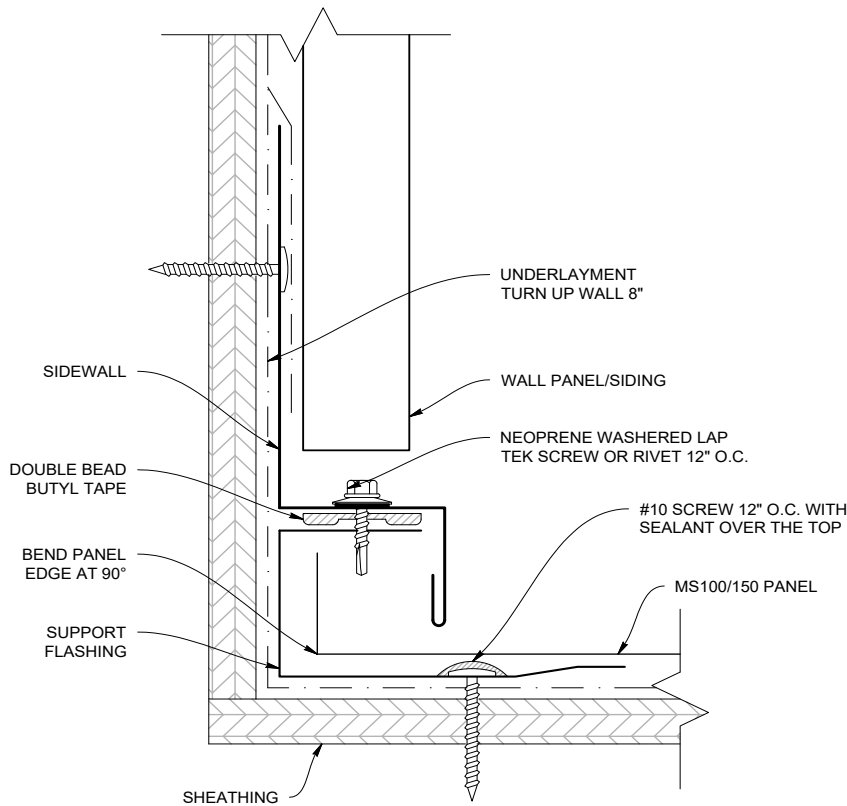

SIDEWALL (MS150SW / MS100SW)

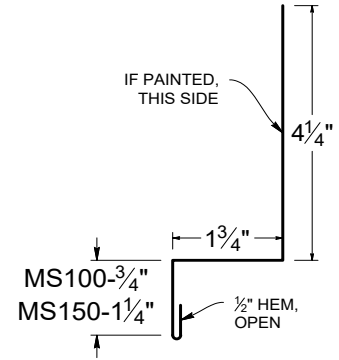

SUPPORT FLASHING (MS150SF / MS100SF)

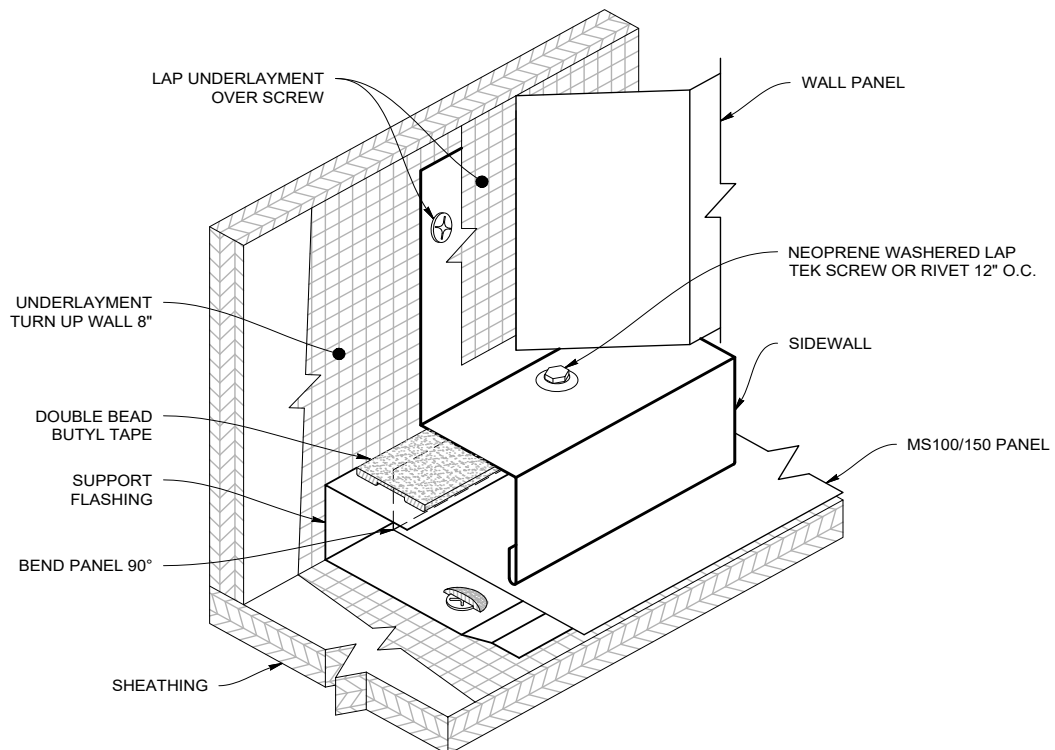
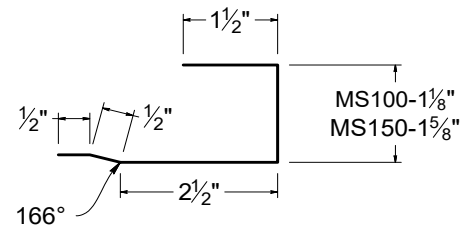

Note: All screws must be fastened into solid substrate.
Flashing must be lapped 4" with 3 rows of gunnable sealant.

Peak Flashing

(Ridge End Cap)

PEAK FLASHING DETAIL

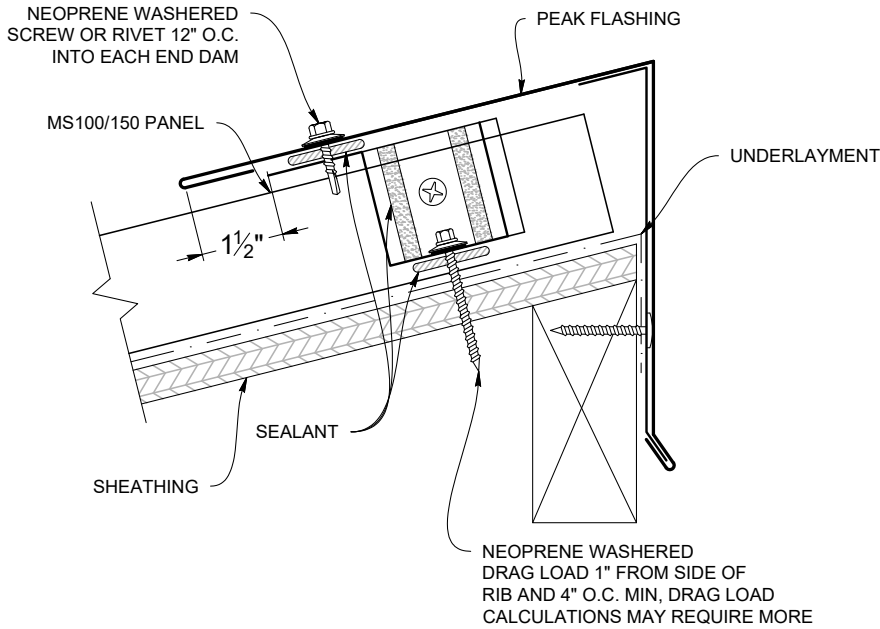

PEAK FLASHING (MS100REC / MS150REC)

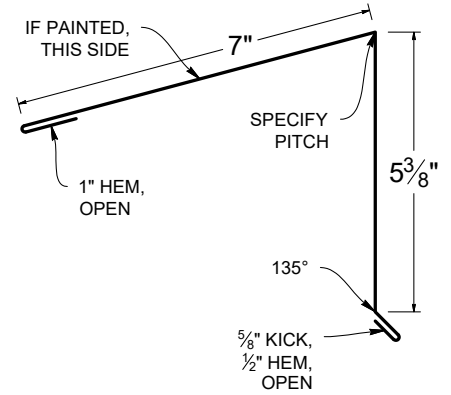

PEAK CLEAT (MS100RECC / MS150RECC)

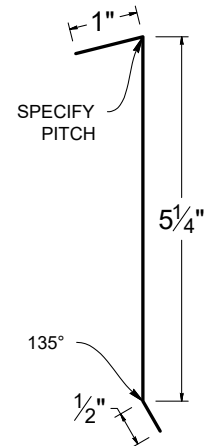

PEAK FLASHING LAP

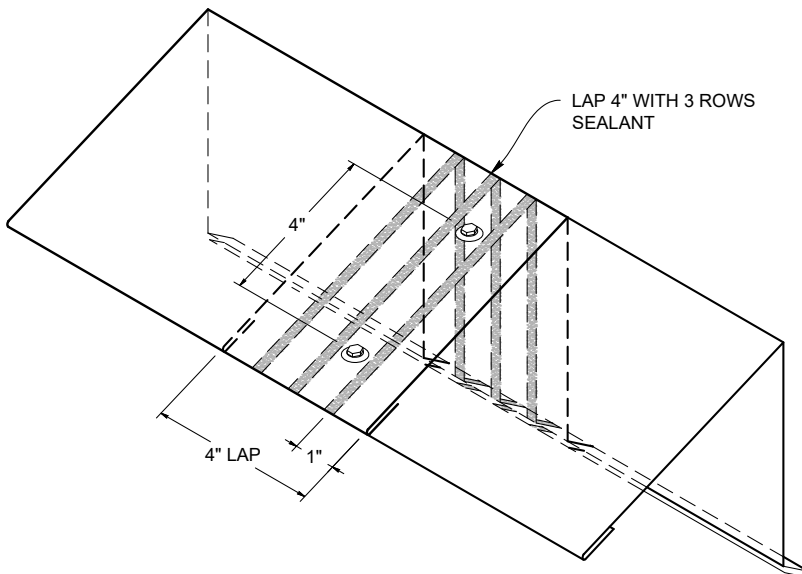

Note: All screws must be fastened into solid substrate.
Flashing must be lapped 4" with 3 rows of gunnable sealant.

WT VENTED PEAK FLASHING DETAIL (Vented Ridge End Cap)

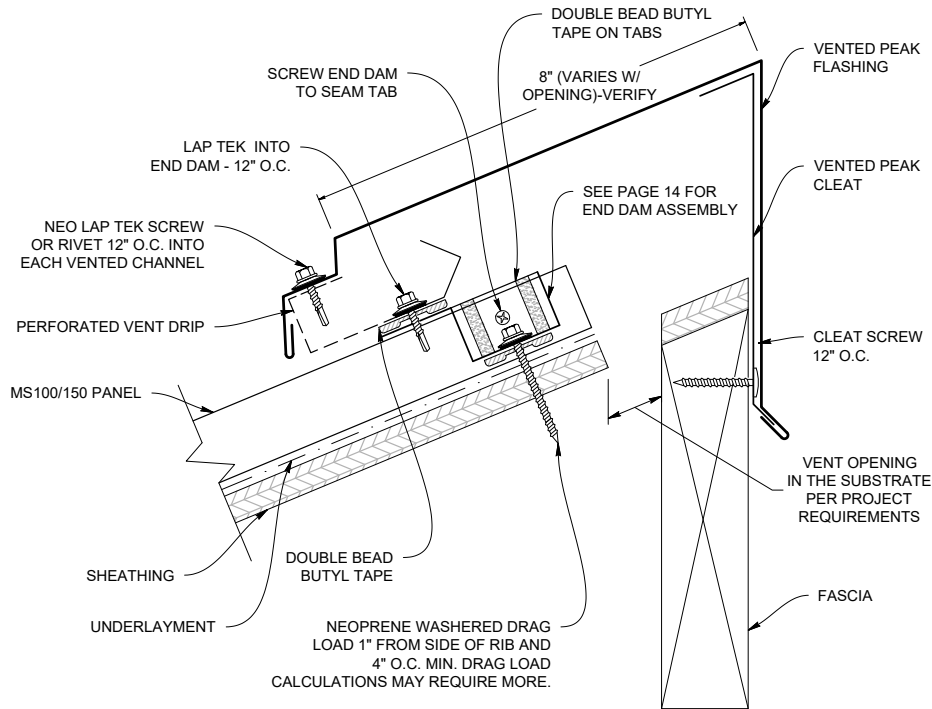

VENTED PEAK CLEAT (MS100VRECC / MS150VRECC)

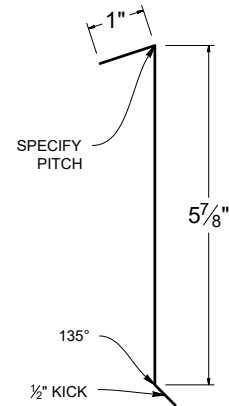

WT VENTED PEAK FLASHING (MS100WTRECV / MS150WTRECV)

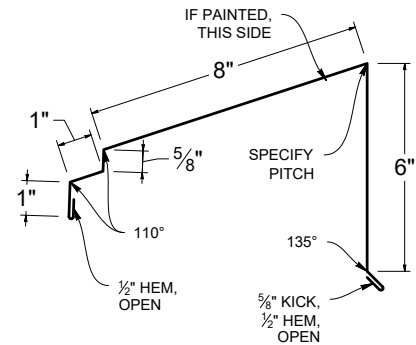

VENTED PEAK FLASHING LAP

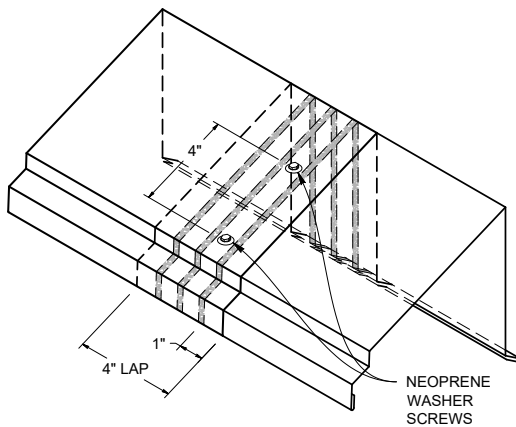

PEAK FLASHING (MS100PVD / MS150PVD)

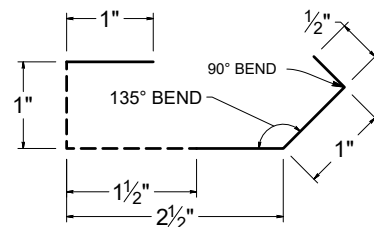

Note: All screws must be fastened into solid substrate.
Flashing must be lapped 4" with 3 rows of gunnable sealant.

PITCH CHANGE DETAIL

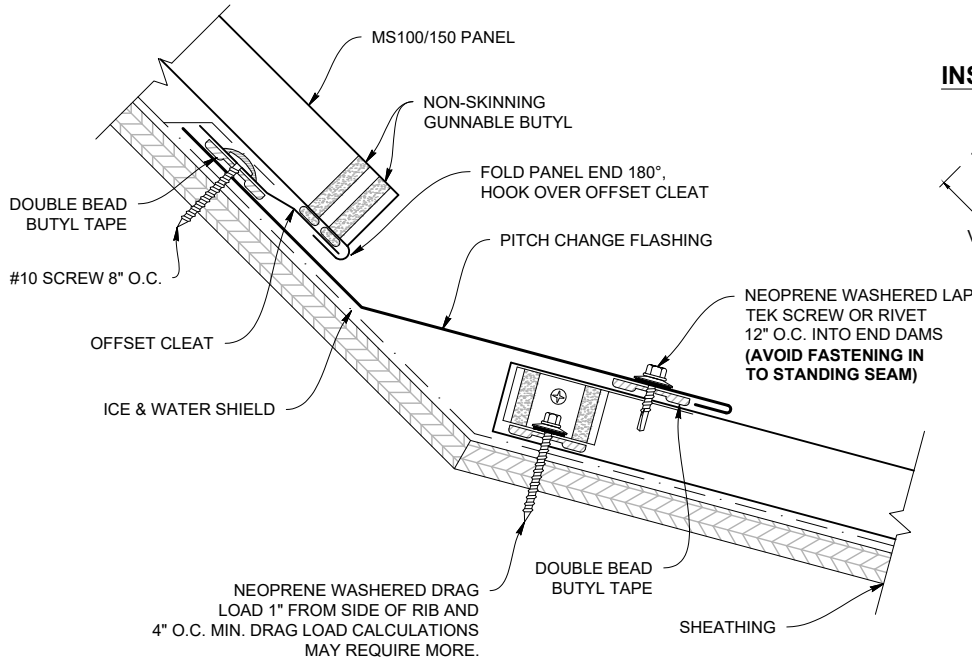

INSIDE PITCH CHANGE FLASHING

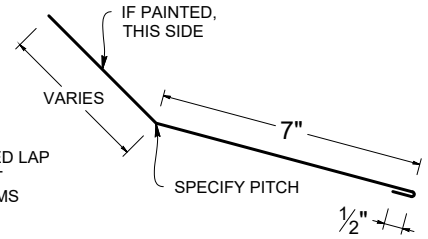

OFFSET CLEAT (MS100OC / MS150OC)

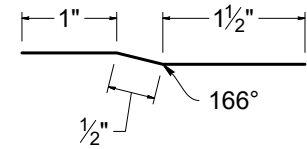

PITCH CHANGE LAP

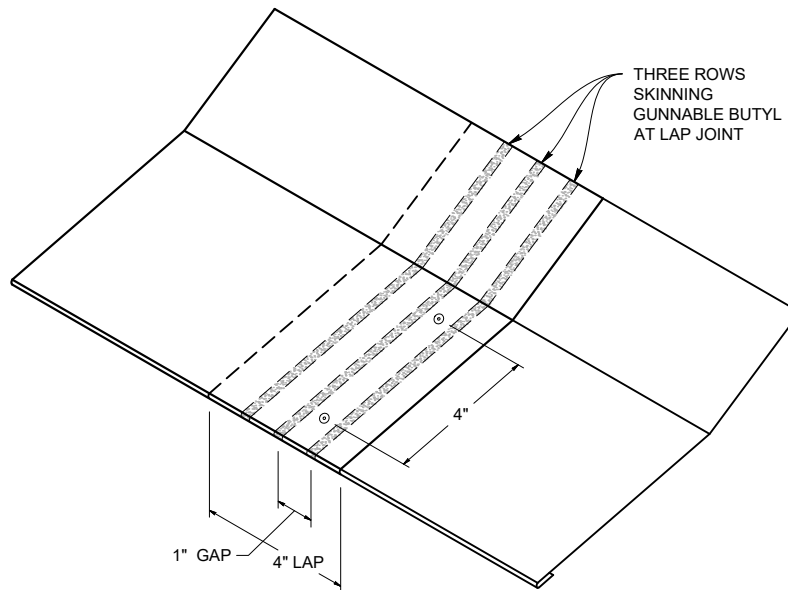

Note: All screws must be fastened into solid substrate.
Flashing must be lapped 4" with 3 rows of gunnable sealant.

ENDWALL DETAIL

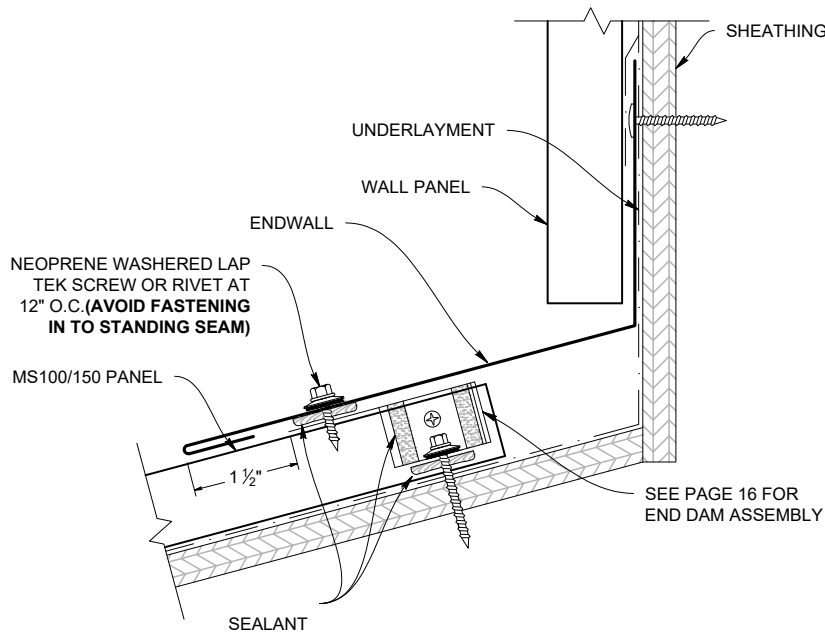

ENDWALL FLASHING (MS150EW / MS100EW)

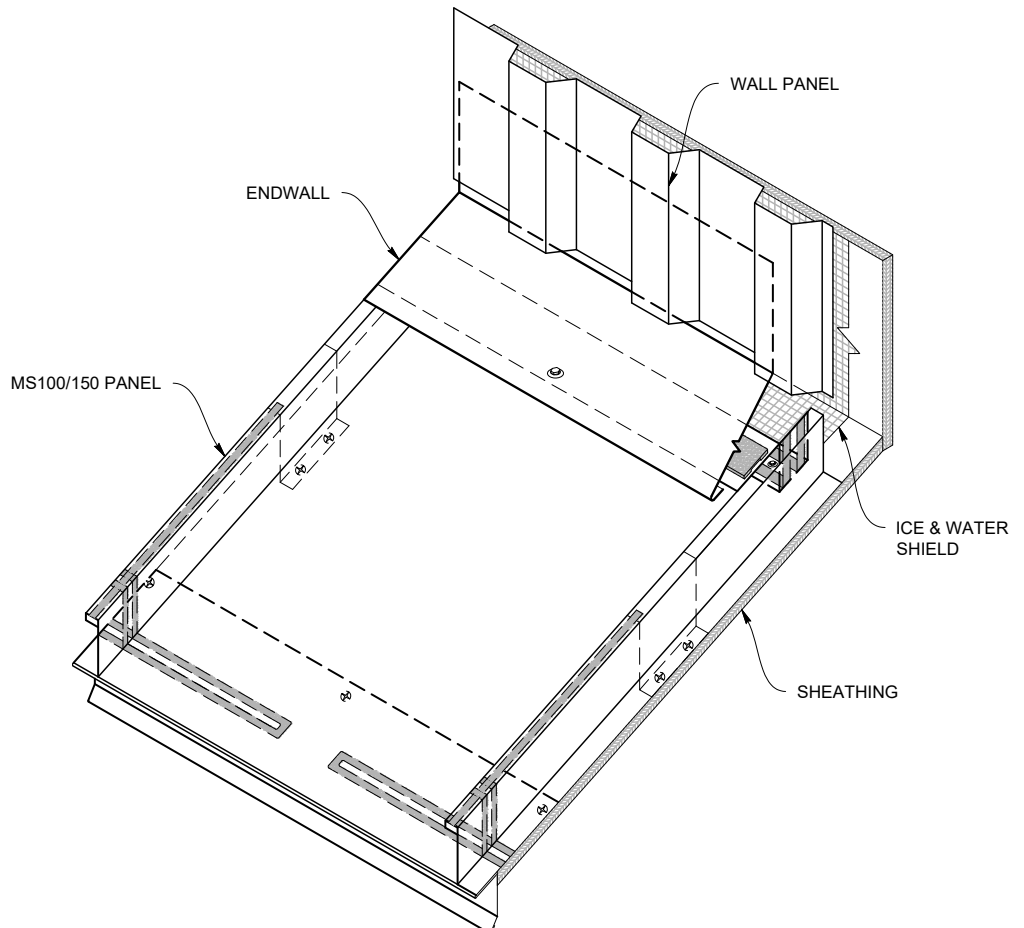
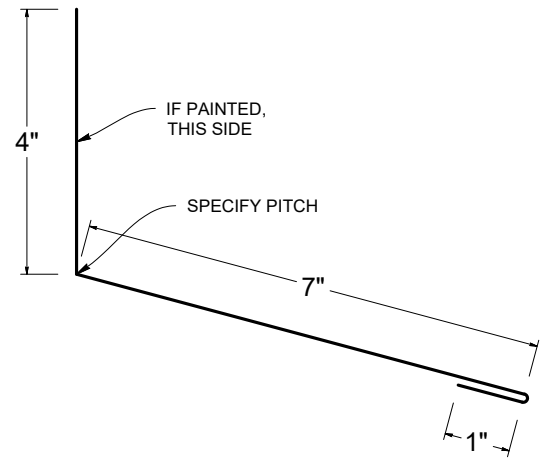

Note: All screws must be fastened into solid substrate.
Flashing must be lapped 4" with 3 rows of gunnable sealant.

Vented Endwall

WT VENTED ENDWALL DETAIL

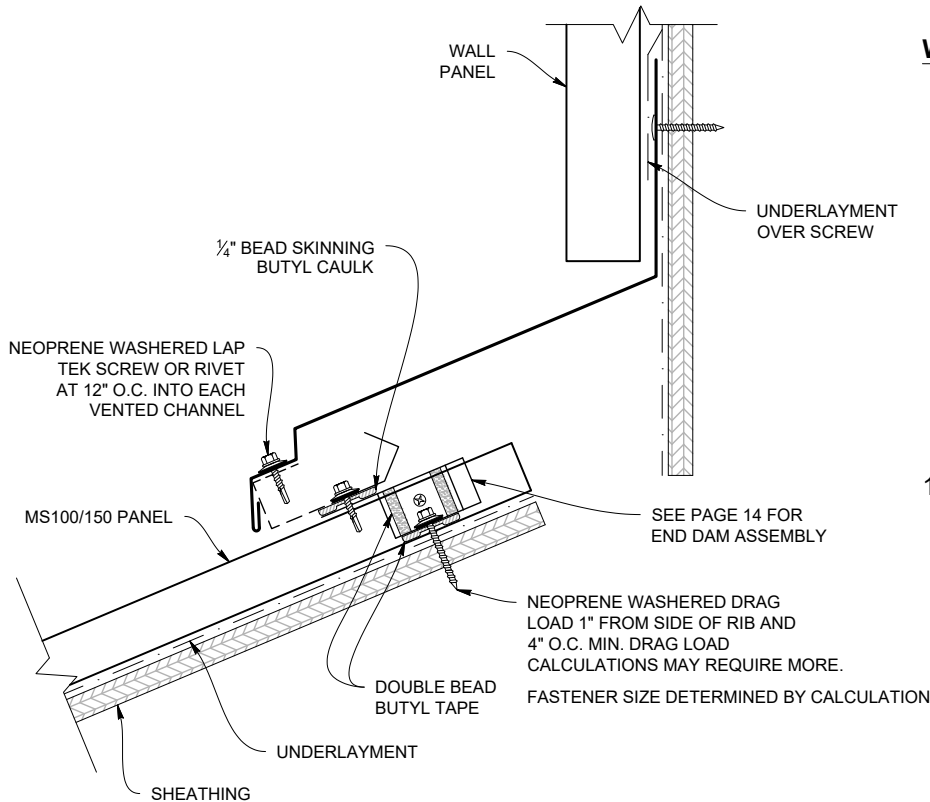

WT VENTED ENDWALL FLASHING (MS150WTEWV / MS100WTEWV)

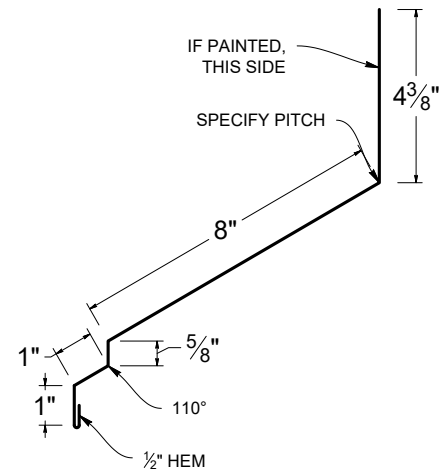

PERFORATED VENT DRIP (MS150PVD / MS100PVD)

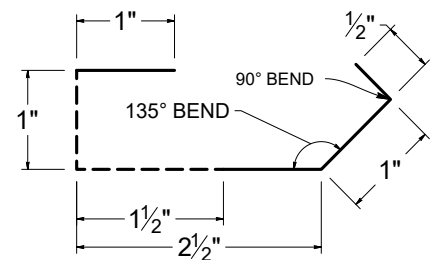

ENDWALL LAP

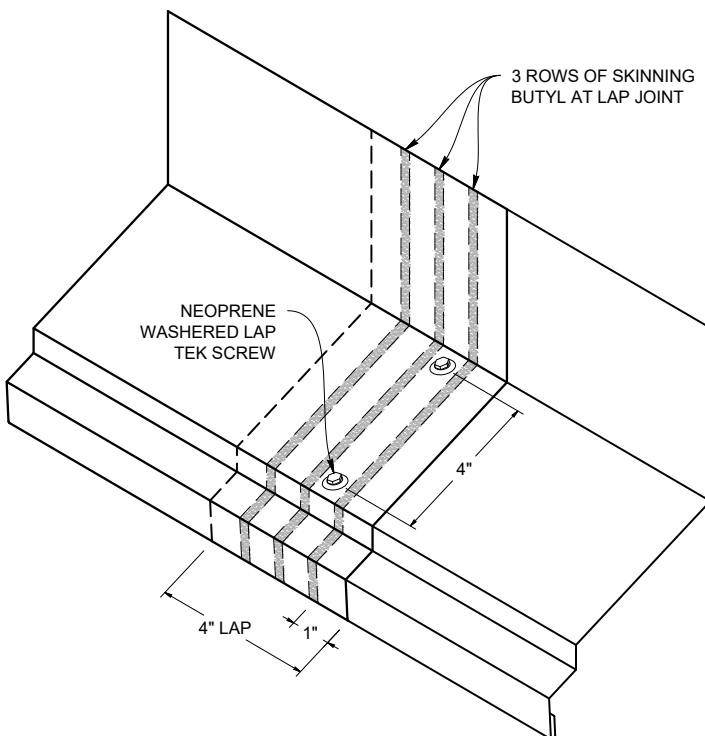

Note: All screws must be fastened into solid substrate.
Flashing must be lapped 4" with 3 rows of gunnable sealant.

CURB SIDEWALL MS150CSW / MS100CSW

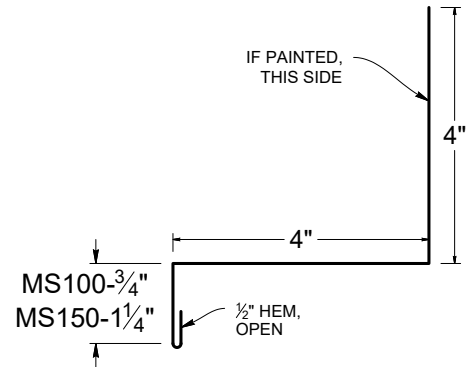
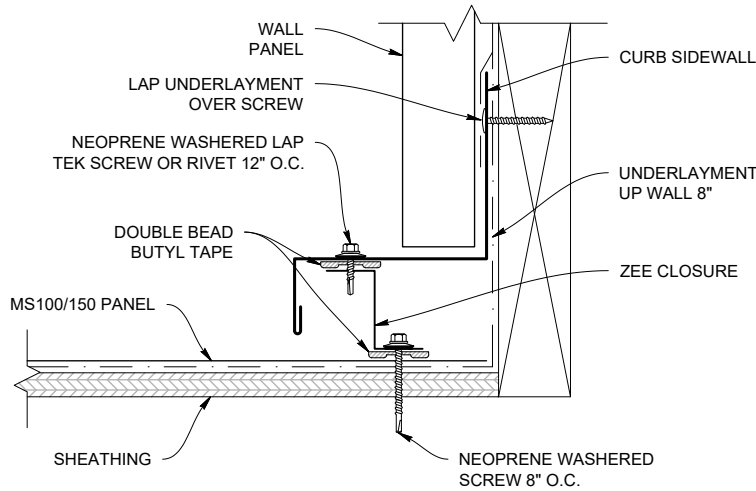

CURB ENDWALL MS150CH / MS100CH

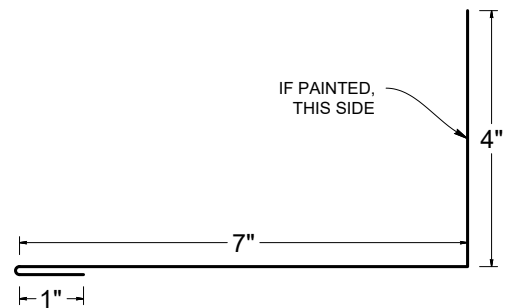
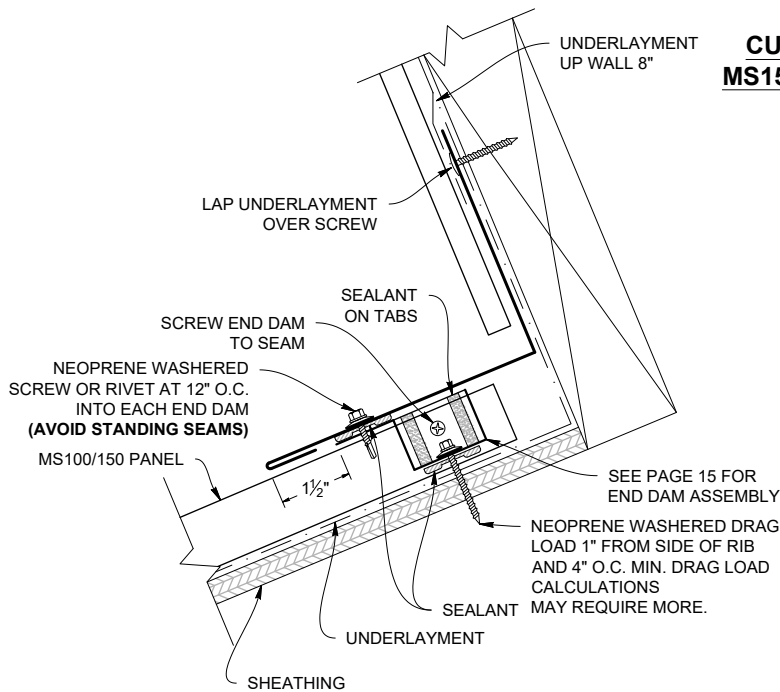

Note: All screws must be fastened into solid substrate.
 Flashing must be lapped 4" with 3 rows of gunnable butyl caulk.

Curb Back Pan/Cricket

STEP 1

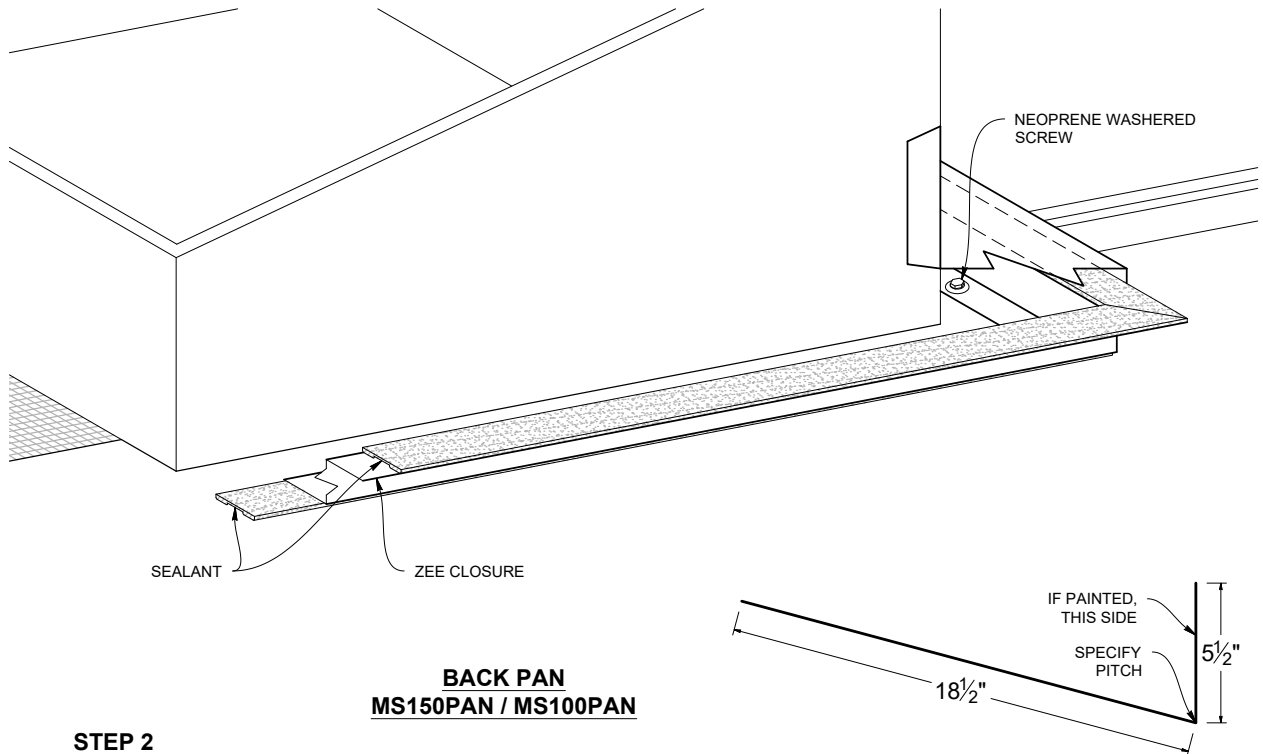

BACK PAN MS150PAN / MS100PAN

STEP 2

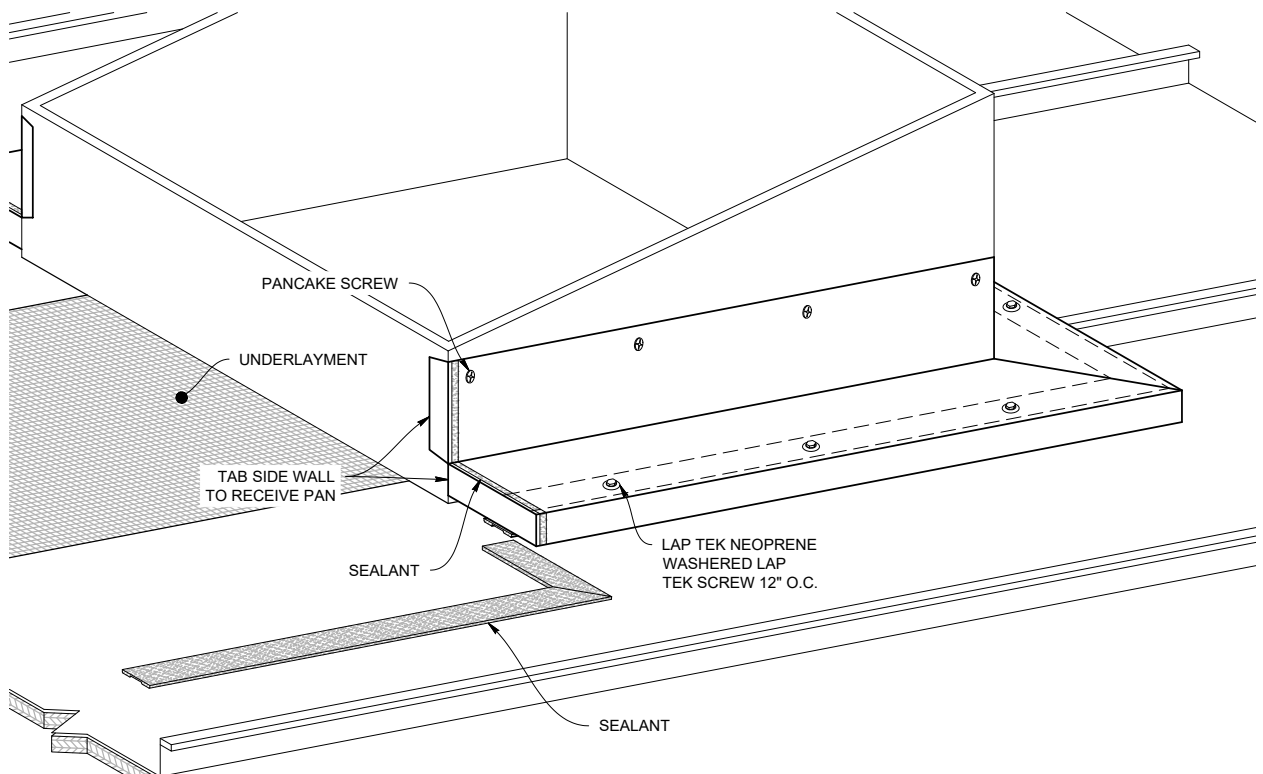

Note: All screws must be fastened into solid substrate.
Flashing must be lapped 4" with 3 rows of gunnable butyl caulk.
Soldered or welded Stainless Steel crickets are allowed - except in corrosive environments

STEP 3

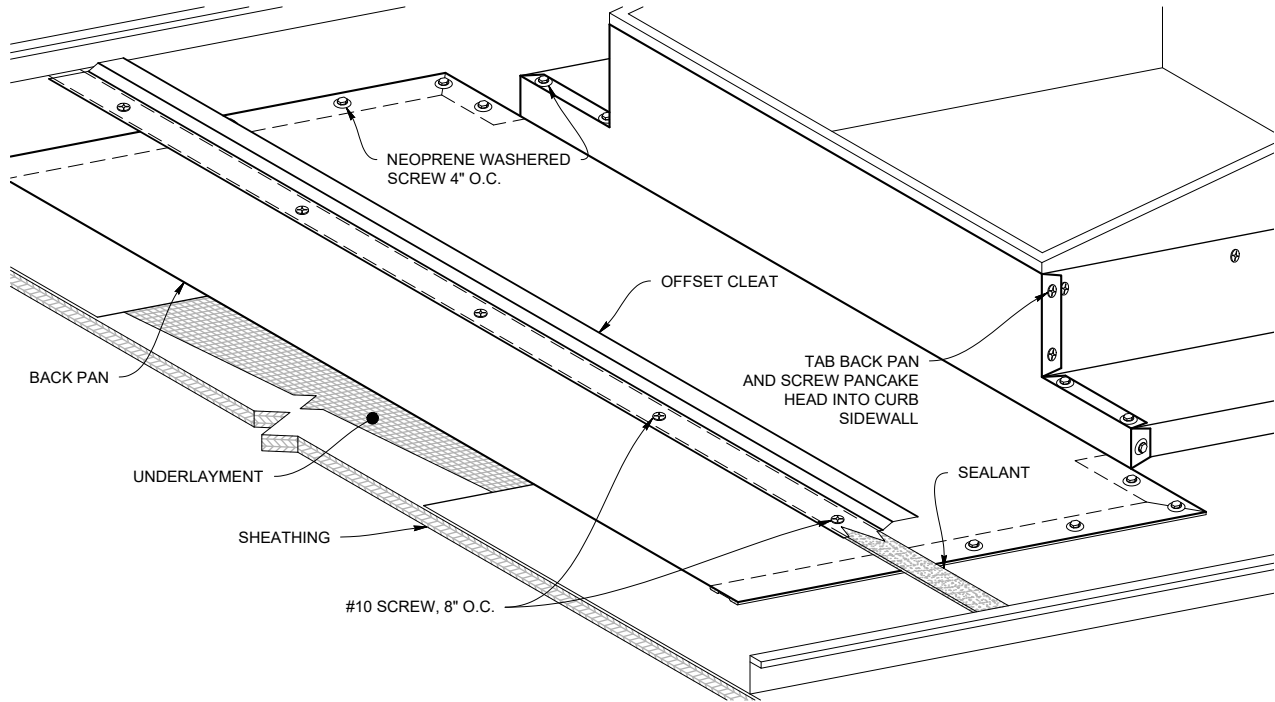

STEP 4

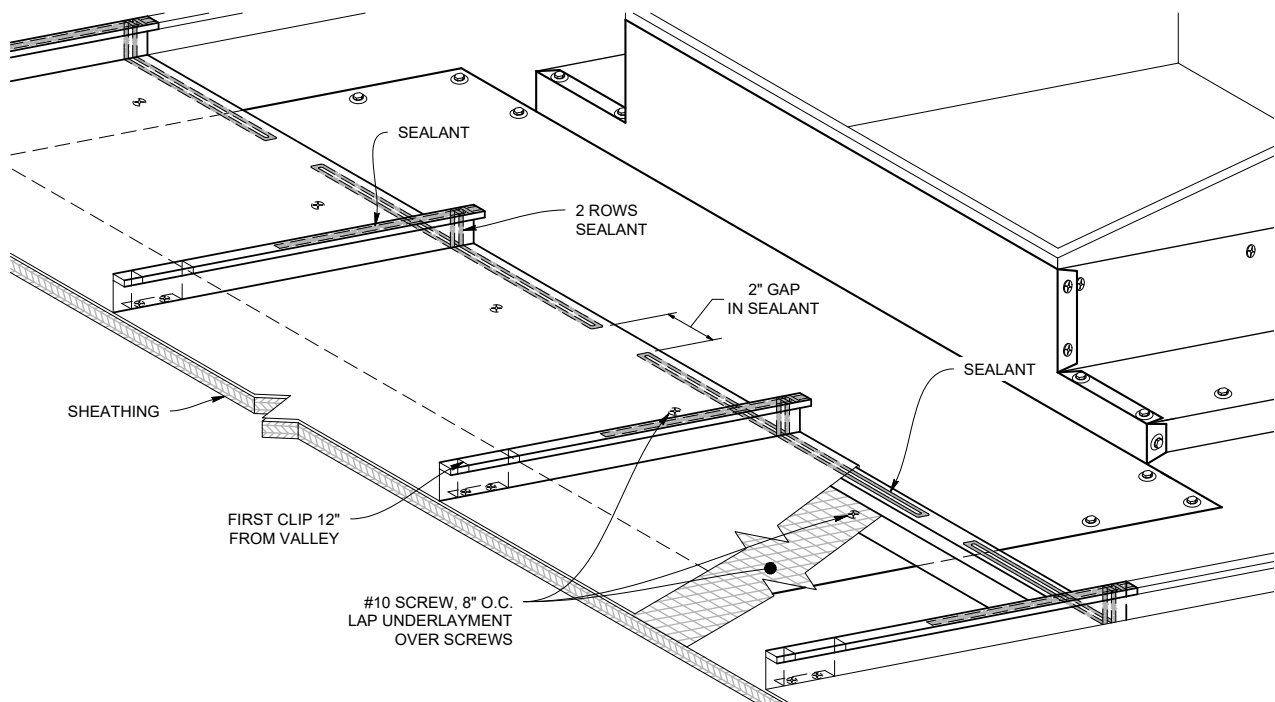

Note: All screws must be fastened into solid substrate.
Flashing must be lapped 4" with 3 rows of gunnable butyl caulk.
Soldered or welded Stainless Steel crickets are allowed - except in corrosive environments

Curb Back Pan/Cricket

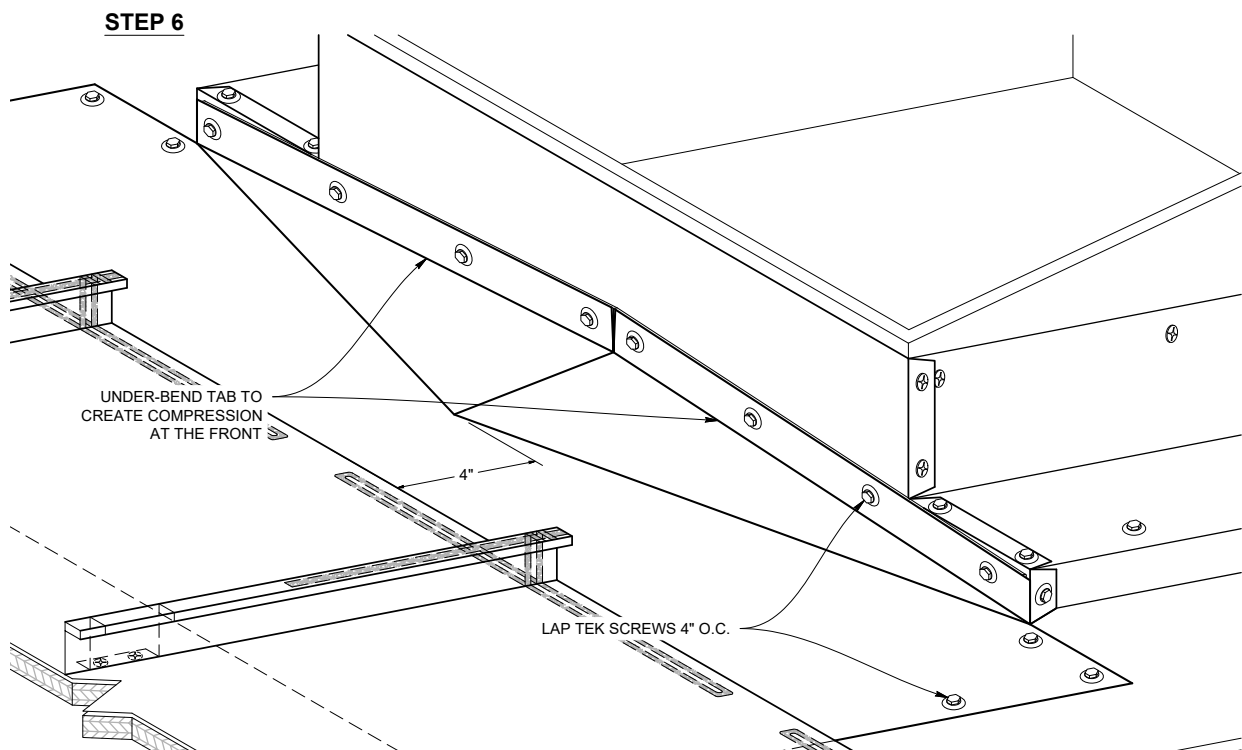
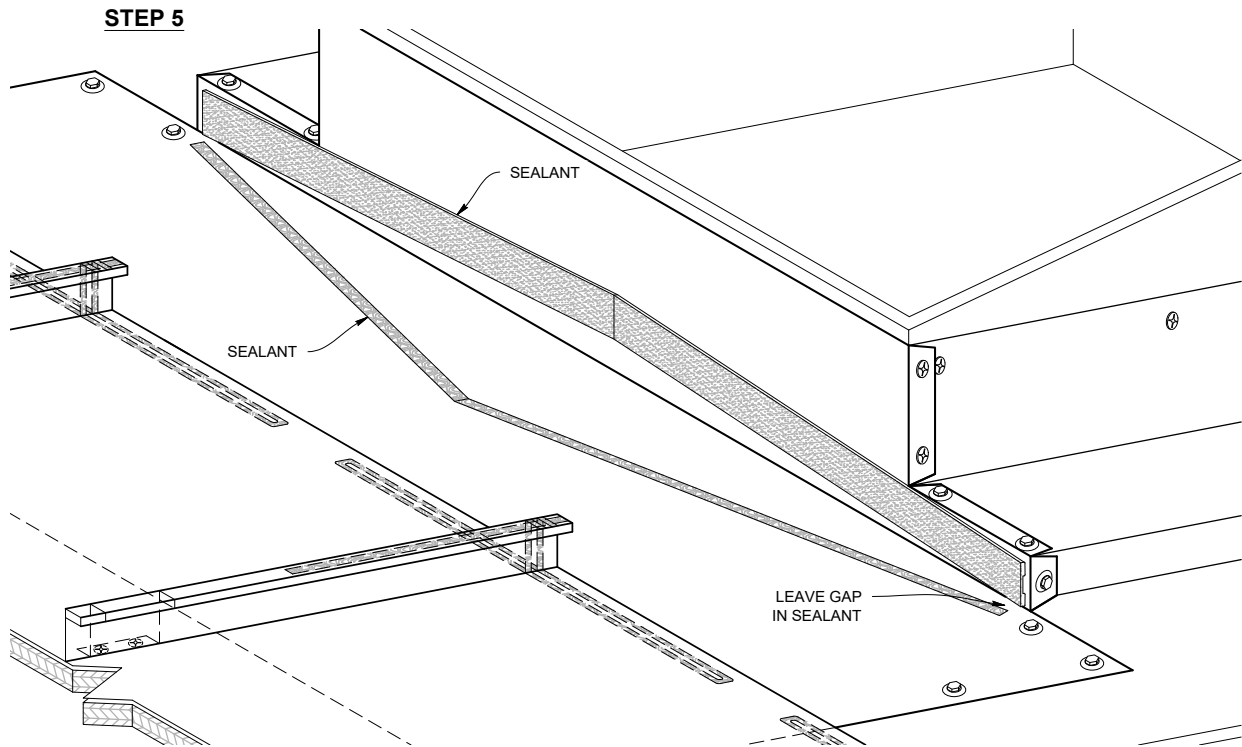

Note: All screws must be fastened into solid substrate.
Flashing must be lapped 4" with 3 rows of gunnable butyl caulk.
Soldered or welded Stainless Steel crickets are allowed - except in corrosive environments

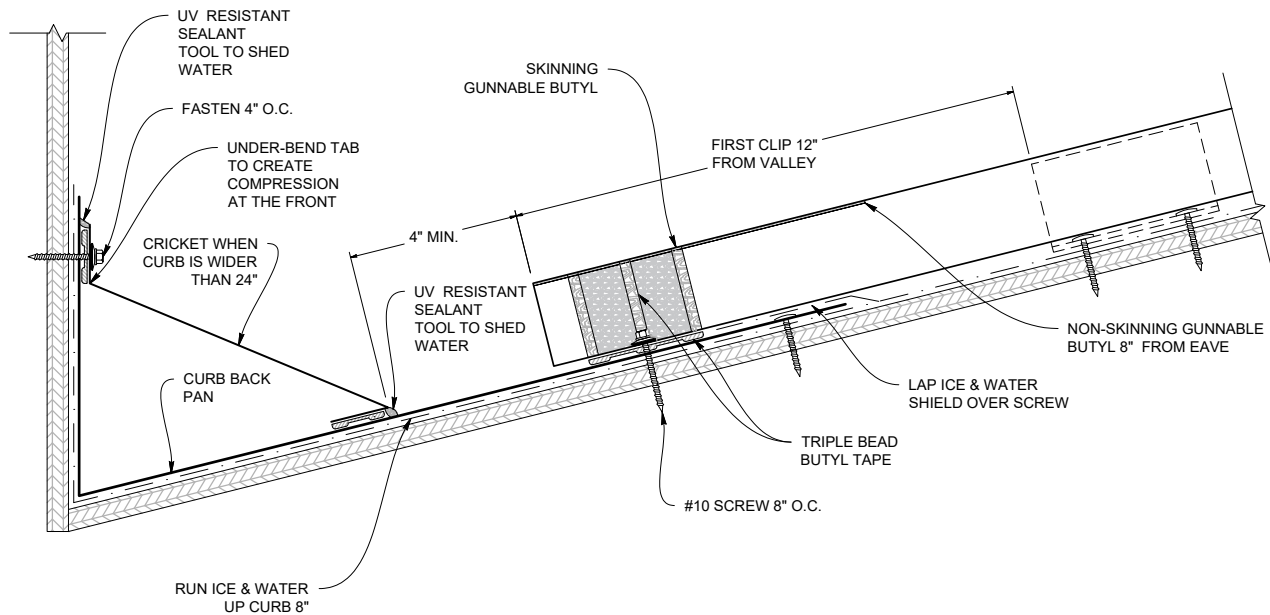
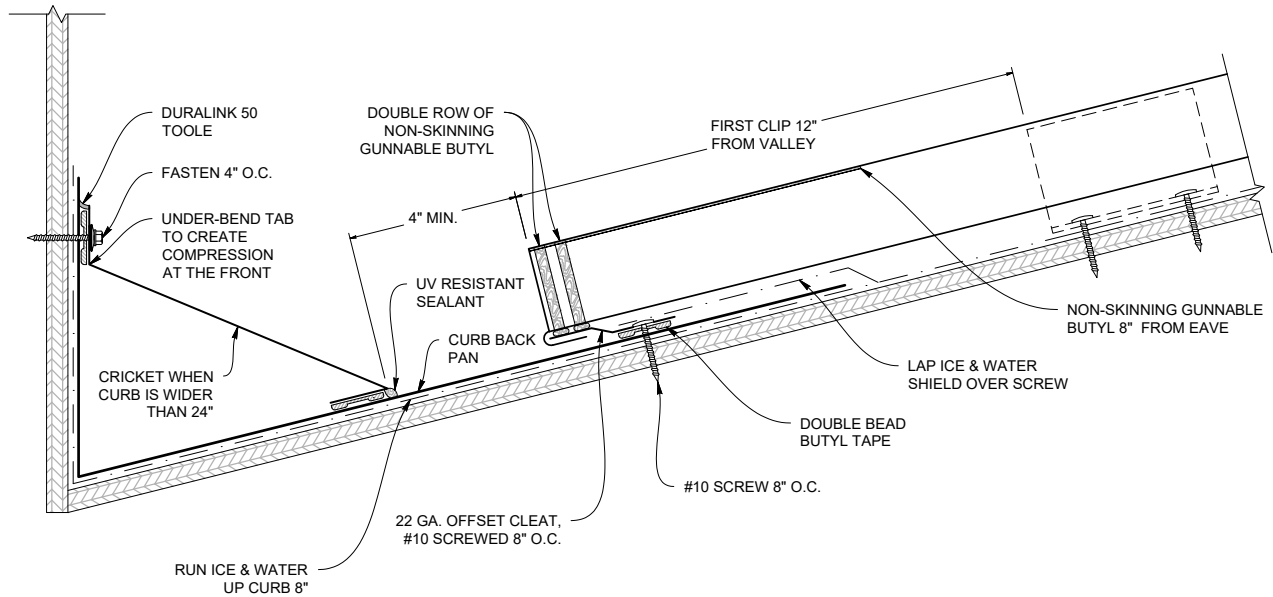

Note: All screws must be fastened into solid substrate.
Flashing must be lapped 4" with 3 rows of gunnable sealant.

Eave to Gable Transition

STEP 1

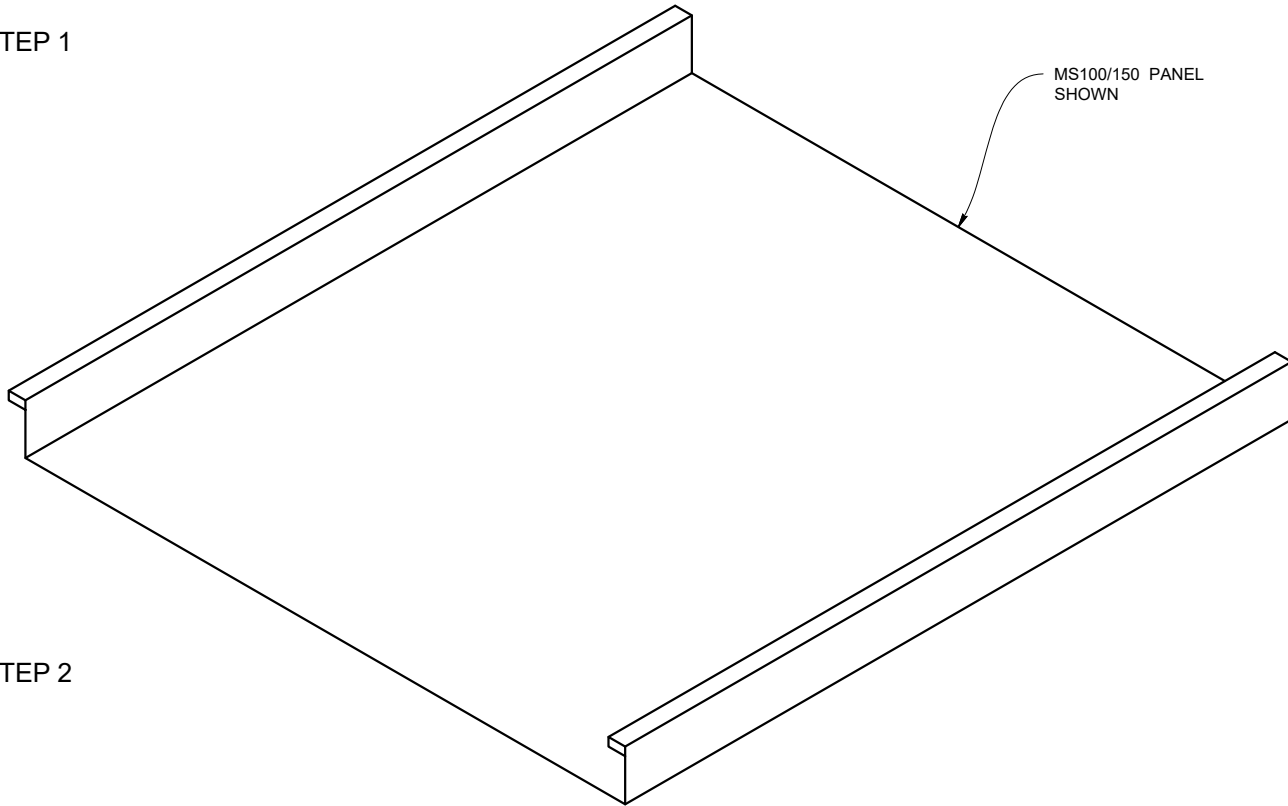

STEP 2

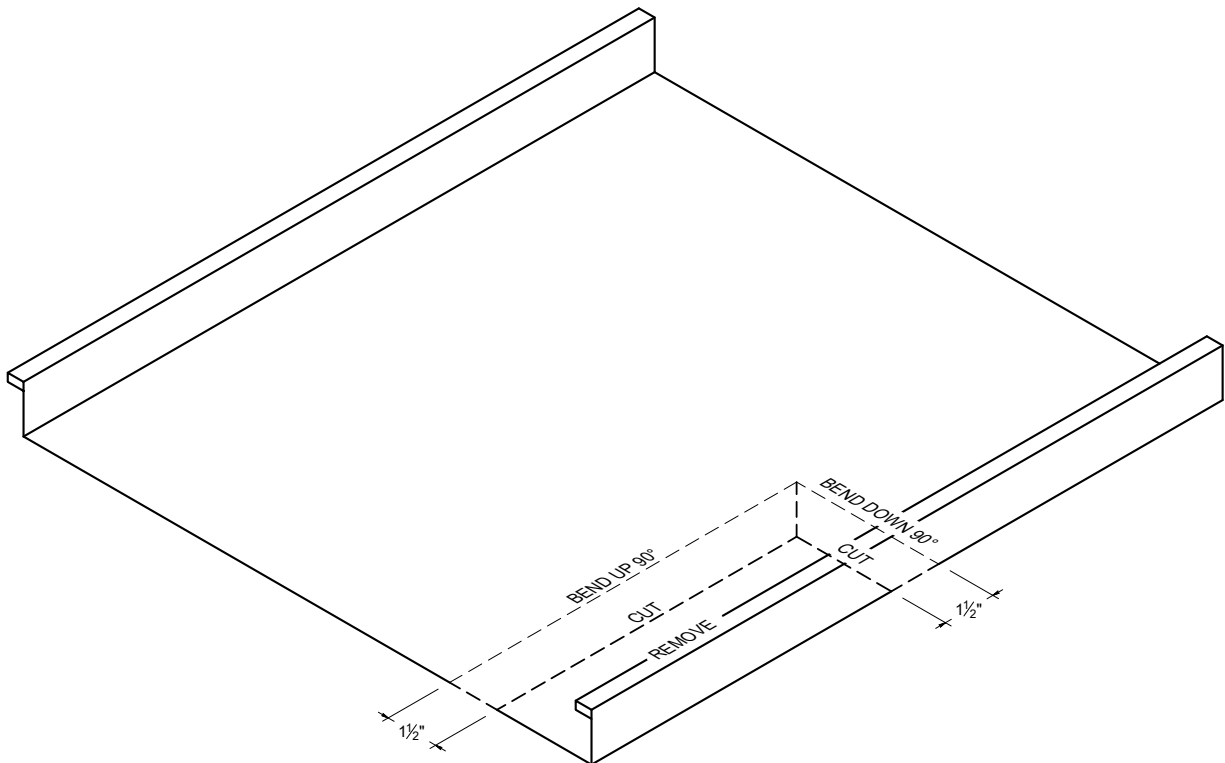

Note: All screws must be fastened into solid substrate.
Flashing must be lapped 4" with 3 rows of gunnable sealant.

STEP 3

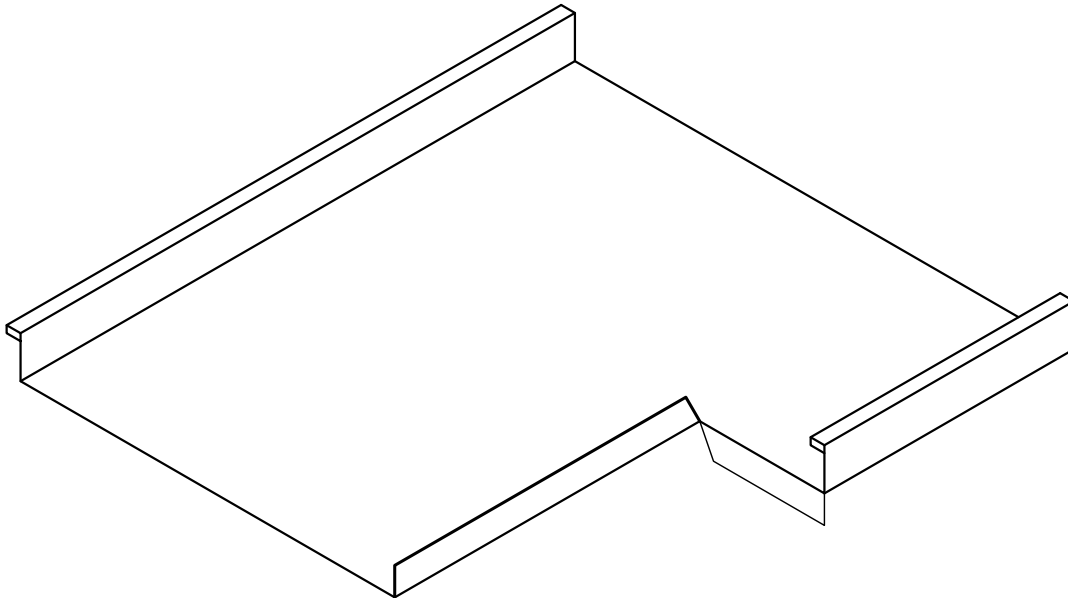

STEP 4

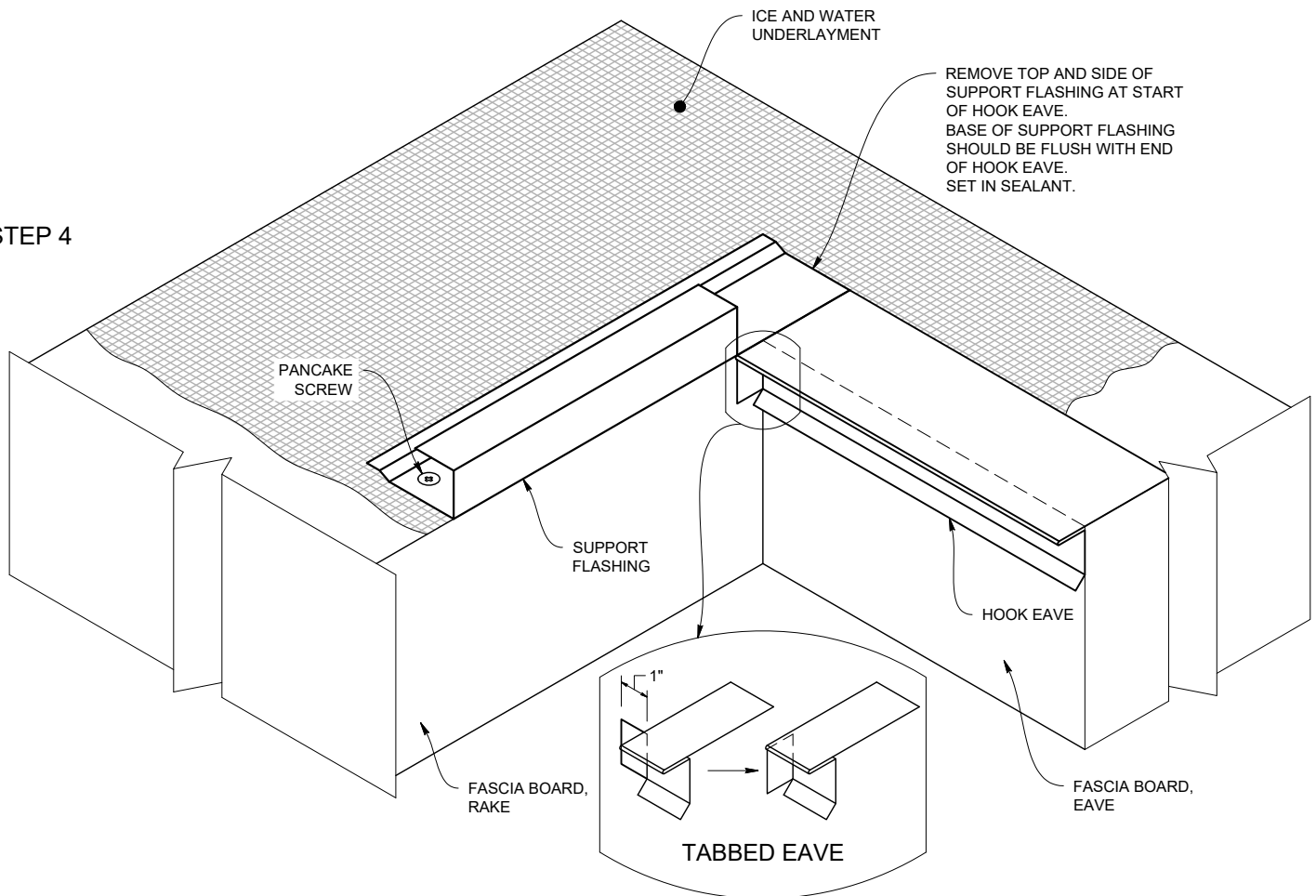

Note: All screws must be fastened into solid substrate.
Flashing must be lapped 4" with 3 rows of gunnable sealant.

Eave to Gable Transition

STEP 5

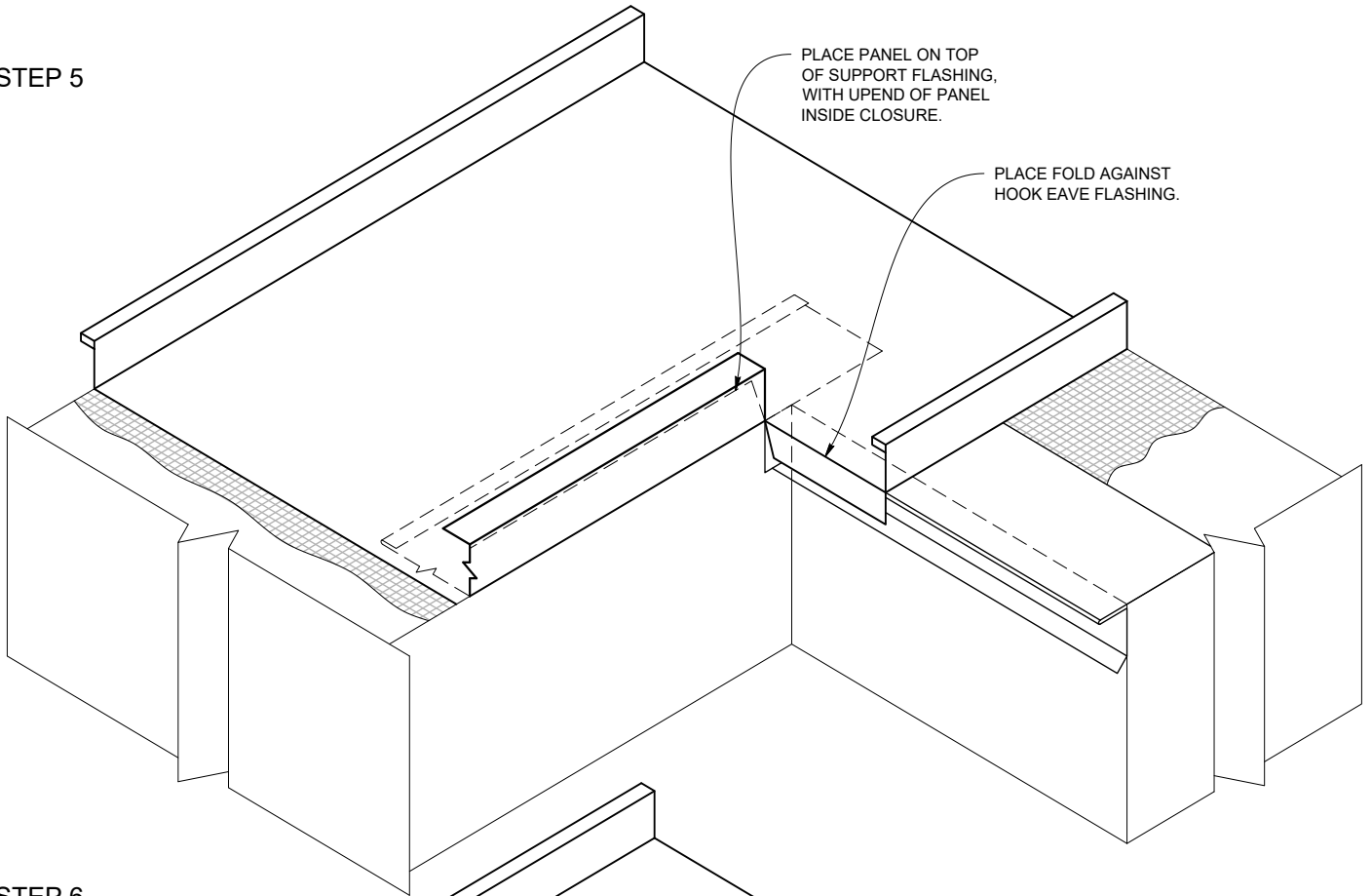

STEP 6

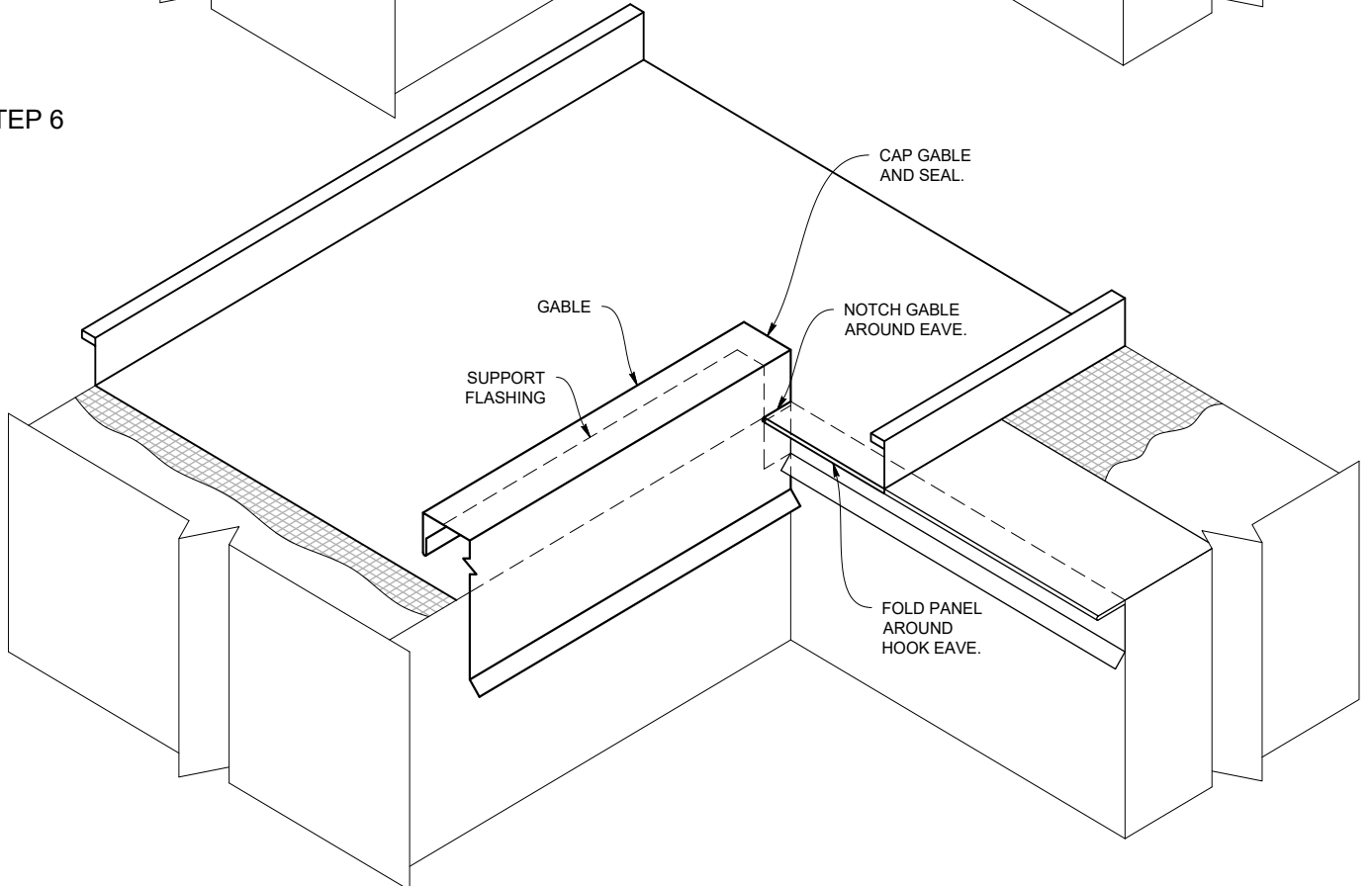

Note: All screws must be fastened into solid substrate.
Flashing must be lapped 4" with 3 rows of gunnable sealant.

FOR PIPES LOCATED 20' OR GREATER FROM PIN POINT

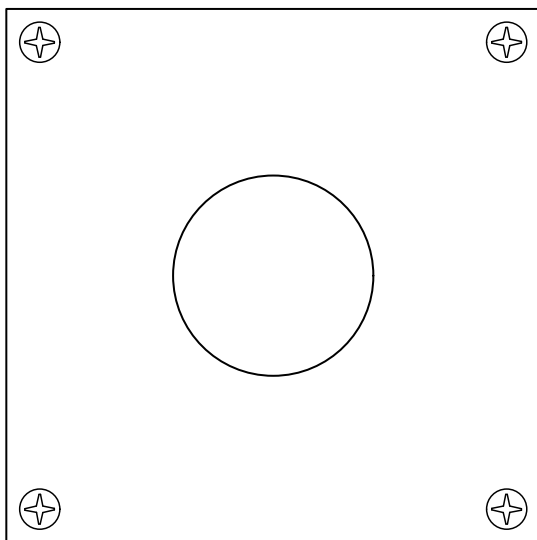
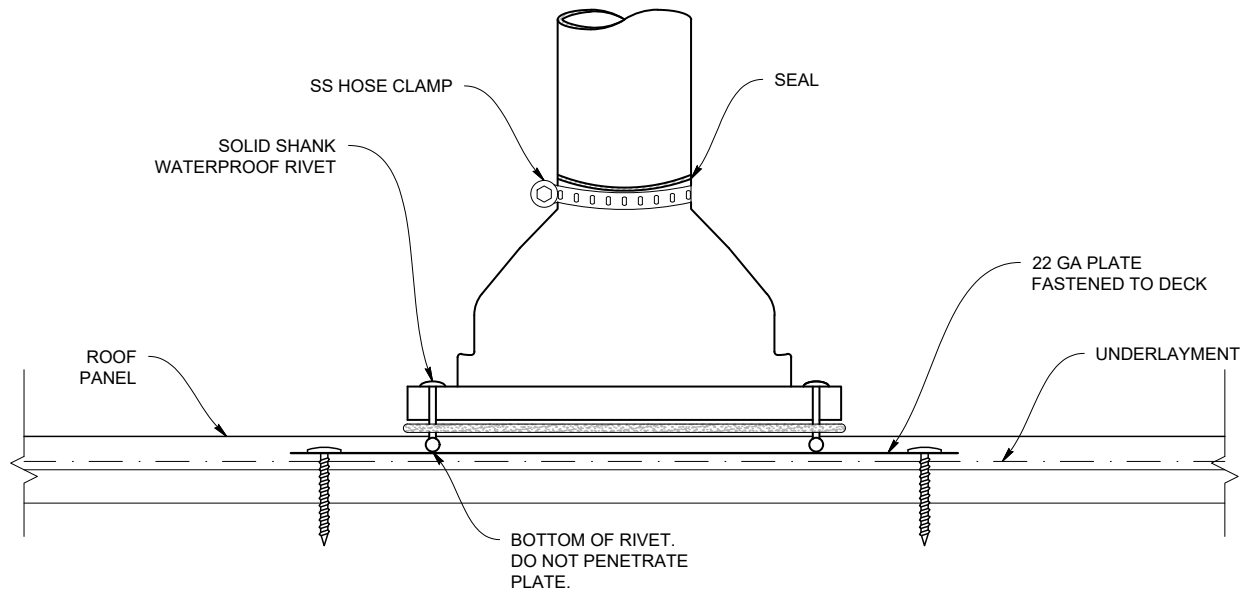

SINGLE 22 GAUGE PLATE

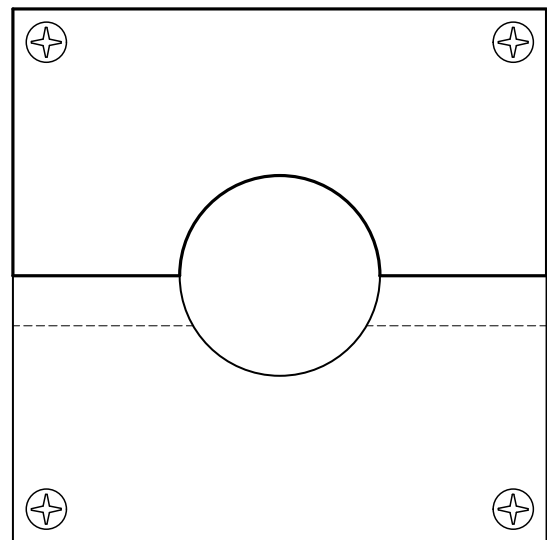

TWO OVERLAPPING 22 GAUGE PLATES

Note: If pipe penetration is over 20 ft. from PIN point, the Z closures shall be riveted to the panel the underlayment covered by 22 ga. skid plate to protect the underlayment from rivets and thermal movement.

Pipe Penetration - on Rib

STEP 1

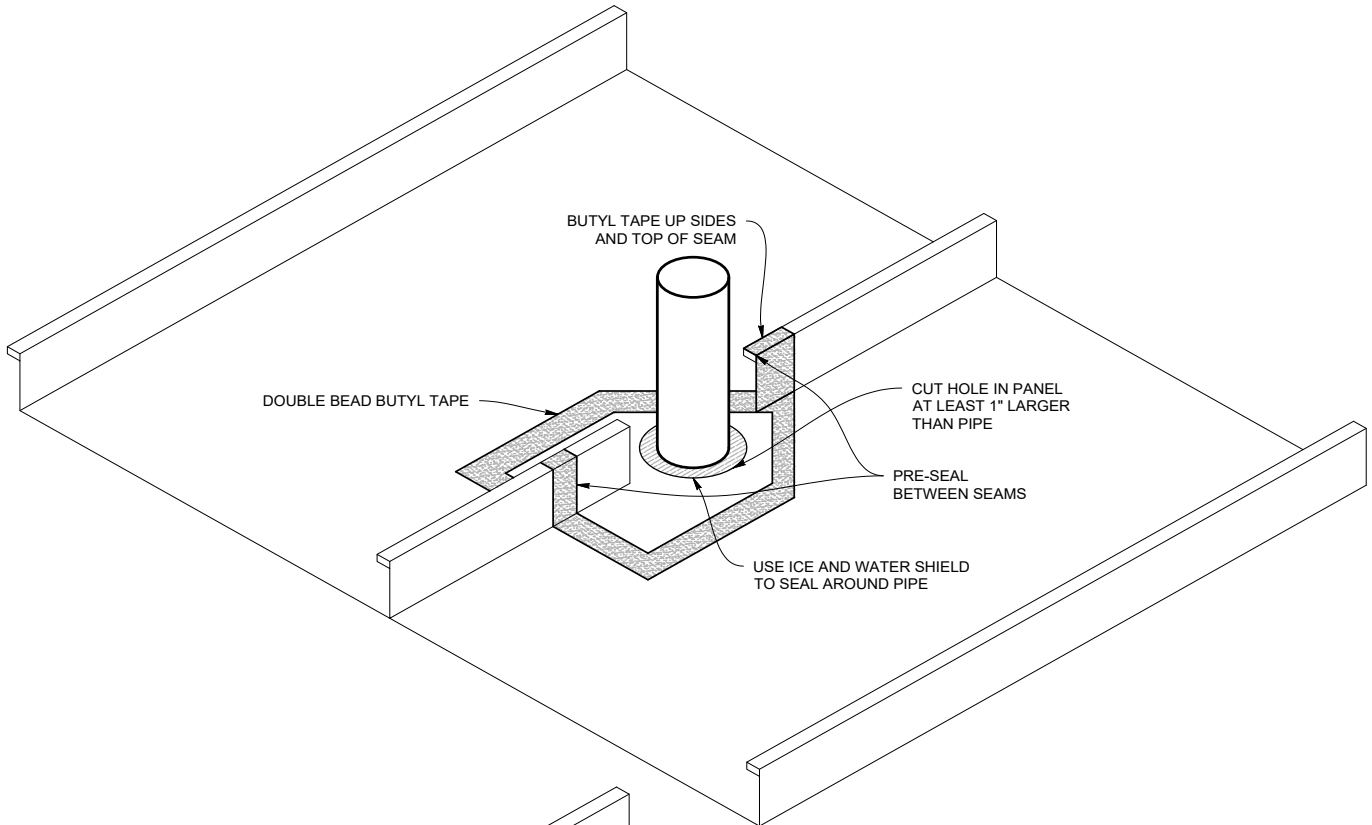

STEP 2

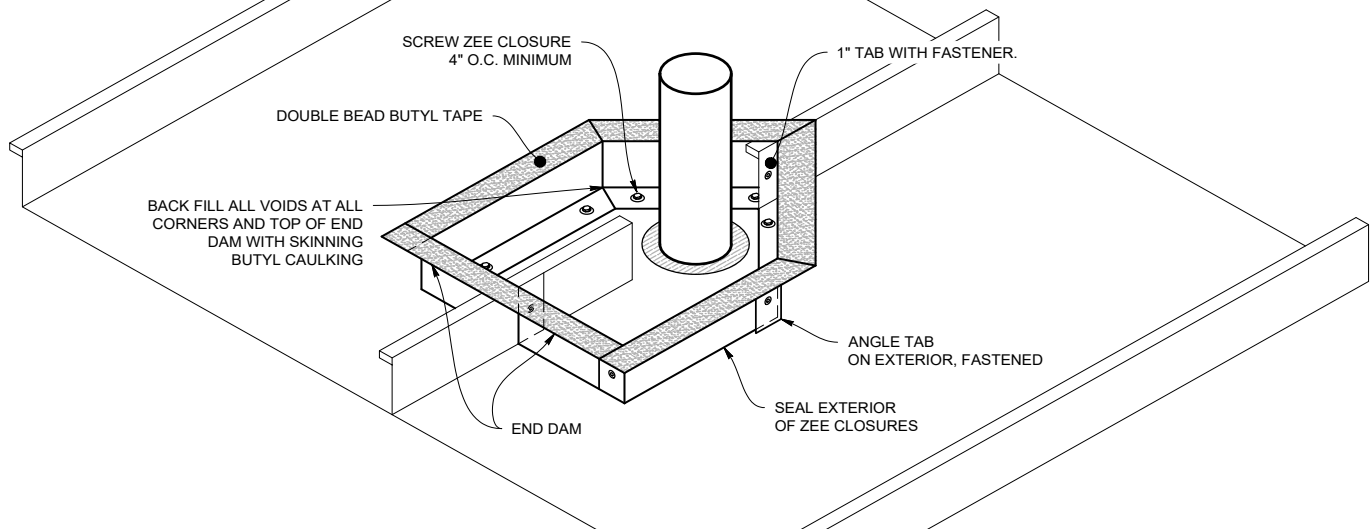

*Use #63 closed end (solid shank) rivets and skid plate when penetration is greater than 20' from fixed pin point when installations are over a solid deck.

Note: All screws must be fastened into solid substrate. Flashing must be lapped 4" with 3 rows of gunnable sealant.

STEP 3

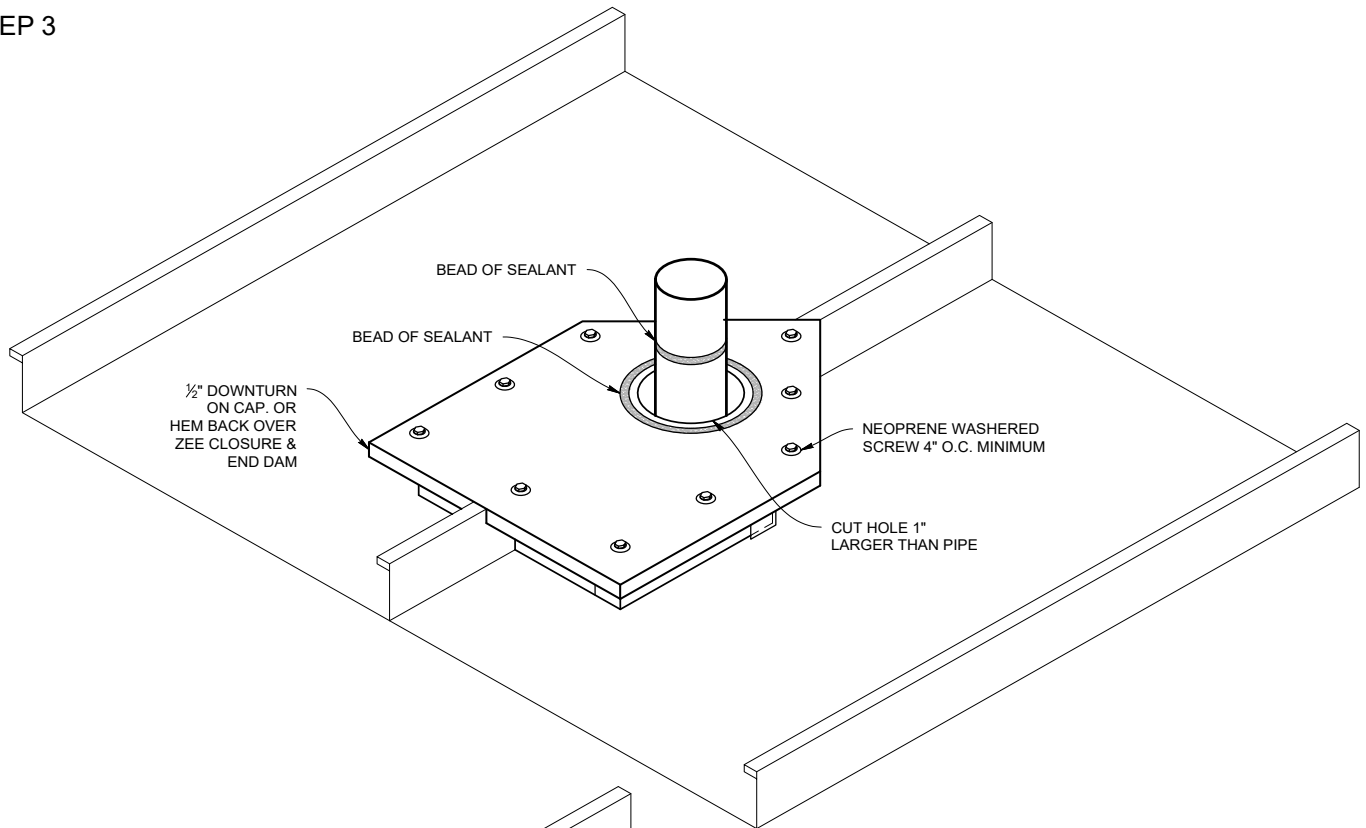

STEP 4

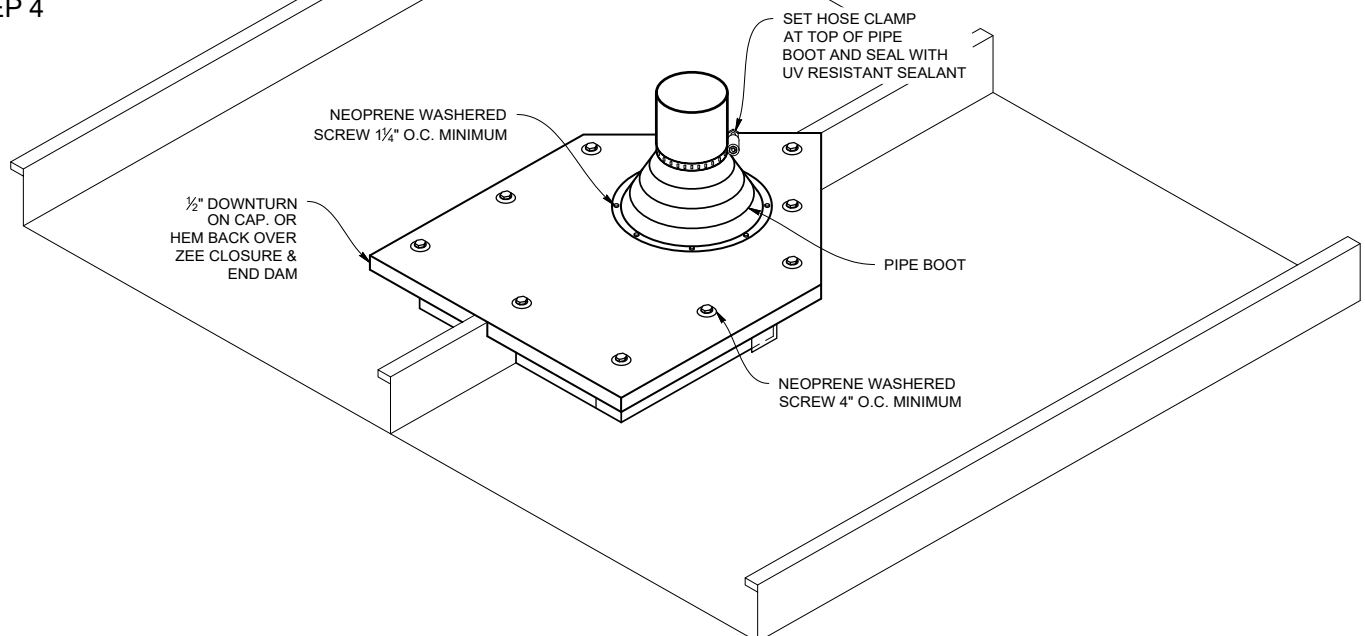

Note: All screws must be fastened into solid substrate. Flashing must be lapped 4" with 3 rows of gunnable sealant.

Pipe Penetration - on Pan

STEP 1

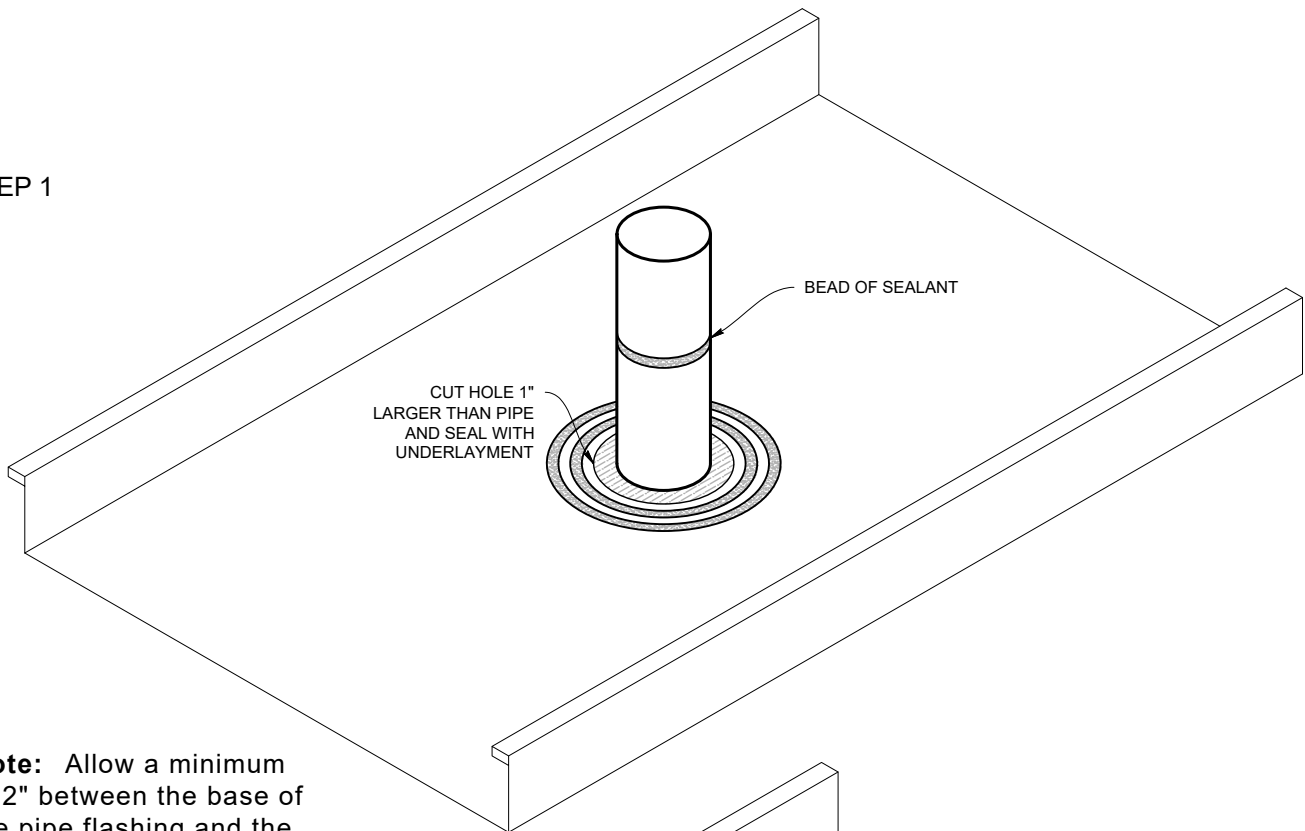

Note: Allow a minimum of 2" between the base of the pipe flashing and the standing seam.

STEP 2

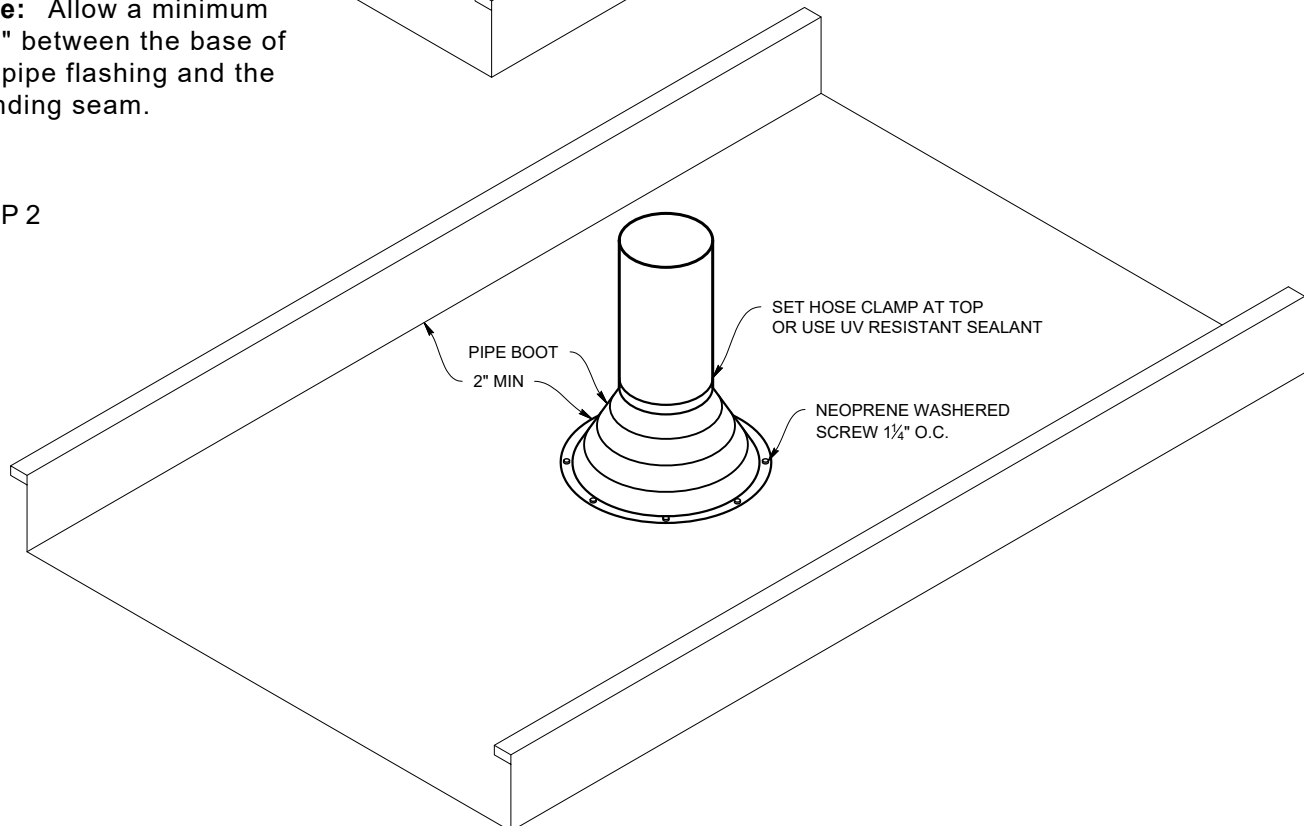

Note: If pipe penetration is over 20 ft. from PIN point, the pipe flashing shall be riveted to the panel the underlayment covered by 22 ga. skid plate to protect the underlayment from rivets and thermal movement.

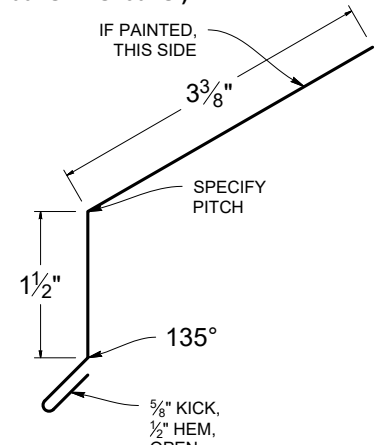
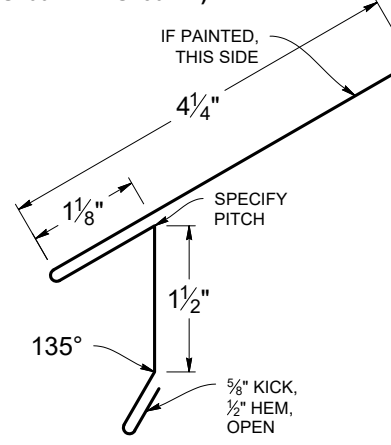
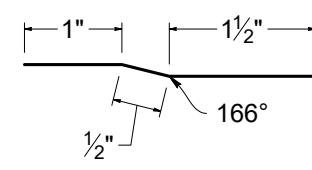
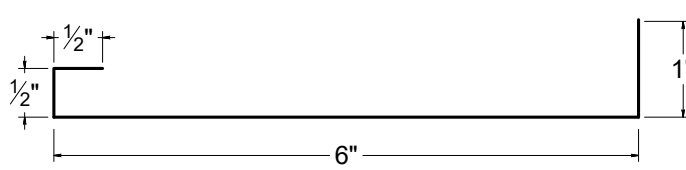
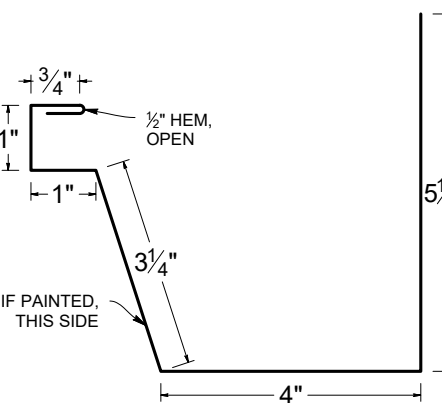
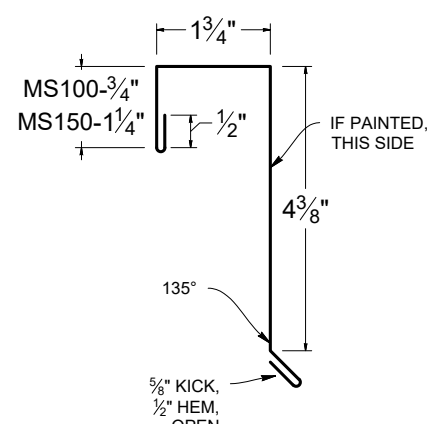
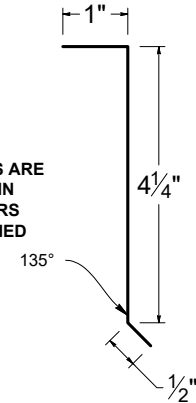
<p>STANDARD EAVE (MS100ES / MS150ES)</p>  <p>IF PAINTED, THIS SIDE</p> <p>3 3/8"</p> <p>SPECIFY PITCH</p> <p>1 1/2"</p> <p>135°</p> <p>5/8" KICK, 1/2" HEM, OPEN</p> <p>SCALE 1:2 S.O. 6" WEIGHT: 4.9 LBS.</p>	<p>HOOK EAVE (MS100EH / MS150EH)</p>  <p>IF PAINTED, THIS SIDE</p> <p>4 1/4"</p> <p>1 1/8"</p> <p>SPECIFY PITCH</p> <p>1 1/2"</p> <p>135°</p> <p>5/8" KICK, 1/2" HEM, OPEN</p> <p>SCALE 1:2 S.O. 8" WEIGHT: 6.5 LBS.</p>	<p>OFFSET CLEAT (MS100OC / MS150OC)</p> <p>NON-VISIBLE / SUB-FLASHINGS ARE NOT PROVIDED IN SPECIFIC COLORS UNLESS SPECIFIED</p>  <p>1"</p> <p>1 1/2"</p> <p>166°</p> <p>1/2"</p> <p>SCALE 1:2 S.O. 3" WEIGHT: 2.5 LBS.</p>
<p>GUTTER HANGER (AGH6)</p>  <p>S.O. 8"</p> <p>WEIGHT: 0.5 LBS.</p> <p>SCALE 1:2</p>		
<p>BOX GUTTER (MS100BG / MS150BG)</p>  <p>3/4"</p> <p>1"</p> <p>1"</p> <p>3 1/4"</p> <p>IF PAINTED, THIS SIDE</p> <p>4"</p> <p>5 1/2"</p> <p>1/2" HEM, OPEN</p> <p>SCALE 1:3 S.O. 16" WEIGHT: 13.3 LBS.</p>	<p>STANDARD GABLE (MS100GS / MS150GS)</p>  <p>1 3/4"</p> <p>MS100-3/4"</p> <p>MS150-1 1/4"</p> <p>1/2"</p> <p>IF PAINTED, THIS SIDE</p> <p>4 3/8"</p> <p>135°</p> <p>5/8" KICK, 1/2" HEM, OPEN</p> <p>SCALE 1:3 S.O. 8.5"/9" WEIGHT: 7.6 LBS.</p>	<p>GABLE CLEAT (MS100GC / MS150GC)</p> <p>NON-VISIBLE / SUB-FLASHINGS ARE NOT PROVIDED IN SPECIFIC COLORS UNLESS SPECIFIED</p>  <p>1"</p> <p>4 1/4"</p> <p>135°</p> <p>1/2"</p> <p>SCALE 1:3 S.O. 5.75" WEIGHT: 4.7 LBS.</p>

MS-100™/MS-150™

Flashing and Details Selection
Flashing: 10' Standard



ALTERNATE GABLE (MS100AT / MS150AT)

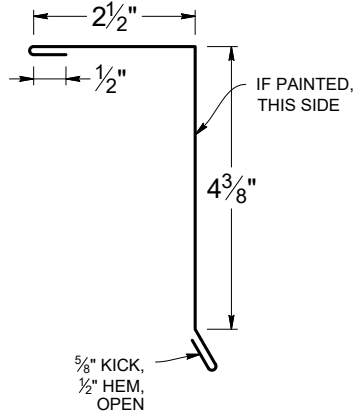

SCALE 1:3 S.O. 8.5" WEIGHT: 7 LBS.

ALTERNATE GABLE CLEAT (MS100AGT / MS150AGT)

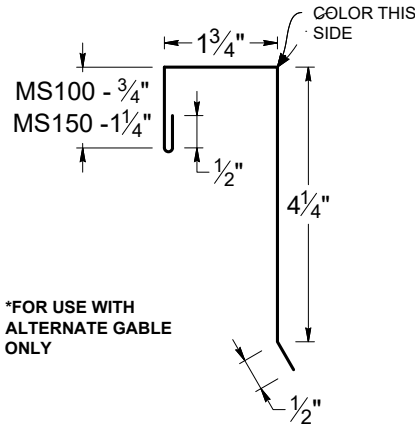

*FOR USE WITH ALTERNATE GABLE ONLY

SCALE 1:3 S.O. 7.75"/8.25" WEIGHT: 4.7 LBS.

SUPPORT FLASHING (MS100SF / MS150SF)

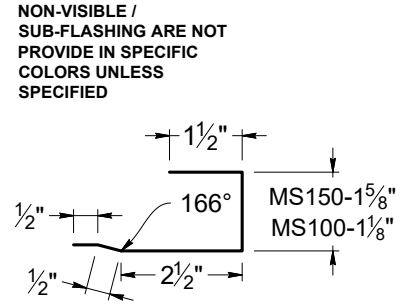

SCALE 1:3 S.O. 6.125"/6.625" WEIGHT: 6 LBS.

PEAK FLASHING (MS100REC / MS150REC)

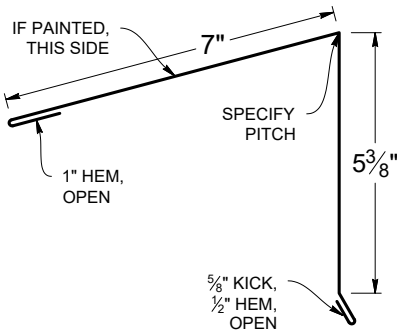

SCALE 1:4 S.O. 14.5" WEIGHT: 11.9 LBS.

WT VENTED PEAK FLASHING (MS100WTRECV / MS150WTRECV)

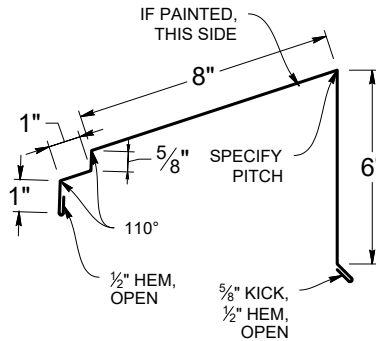

SCALE 1:6 S.O. 18.25" WEIGHT: 12.9 LBS.

VENTED PEAK FLASHING (MS100RECV / MS150RECV)

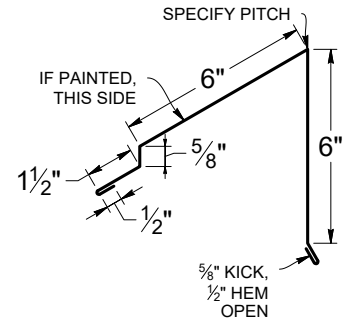

SCALE 1:6 S.O. 15.75" WEIGHT: 12.9 LBS.

PEAK CLEAT (MS100RECC / MS150RECC)

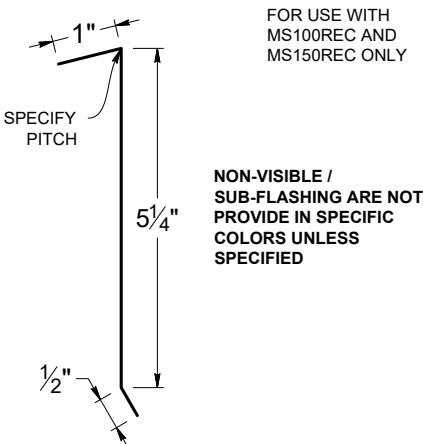

SCALE 1:3 S.O. 6.75" WEIGHT: 6 LBS.

VENTED PEAK CLEAT (MS100VRECC / MS150VRECC)

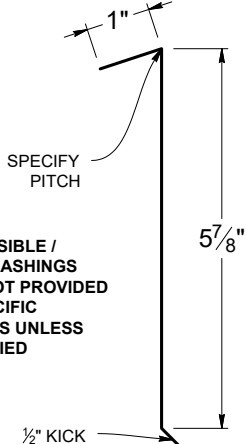

SCALE 1:3 S.O. 7.375" WEIGHT: 2.5 LBS.

VALLEY WIDE FLASHING
(MS100VFW / MS150VFW)

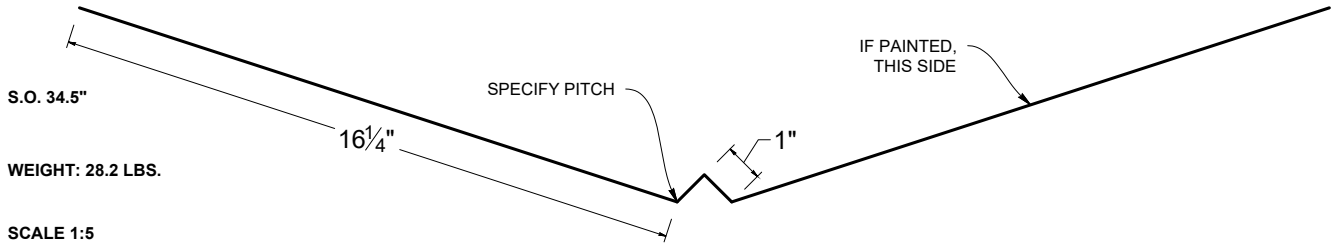

VALLEY FLASHING
(MS100VF / MS150VF)

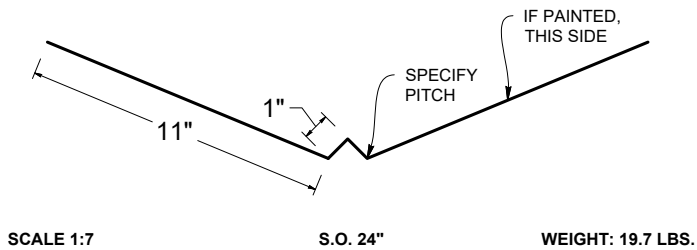

OFFSET CLEAT
(MS100OC / MS150OC)

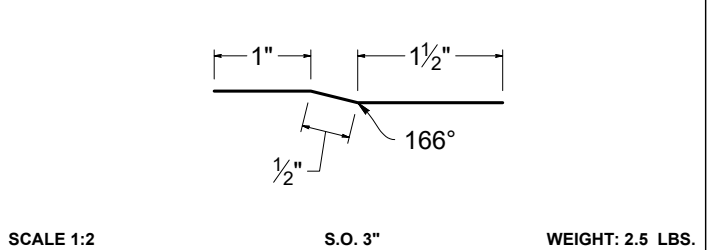

STANDARD RIDGE
(MS100RS / MS150RS)

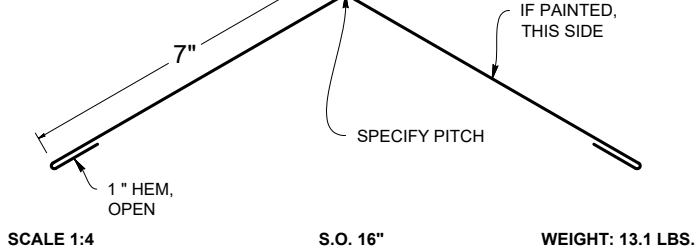

WT RIDGE FULL VENTED
(MS100WTRFV / MS150WTRFV)

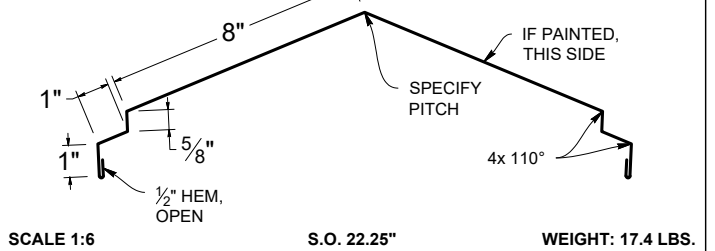

RIDGE FULL VENTED
(MS100RFV / MS150RFV)

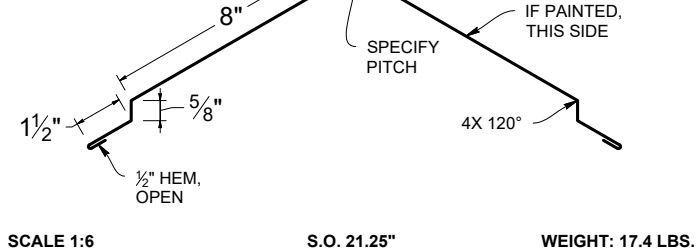

MS-100™ / MS-150™

Flashing and Details Selection
Flashing: 10' Standard

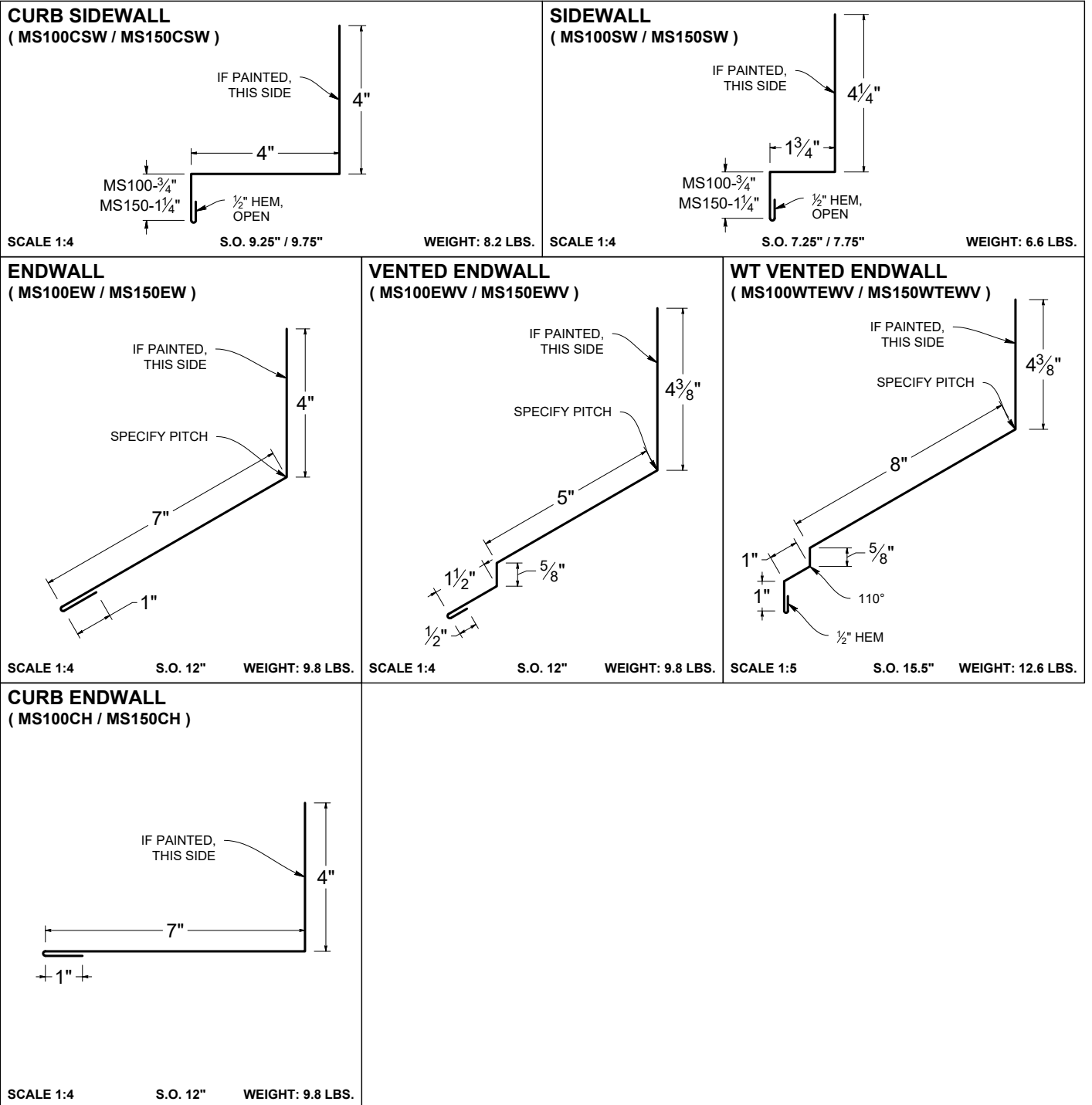

PAN FLASHING
(MS100PAN / MS150PAN)

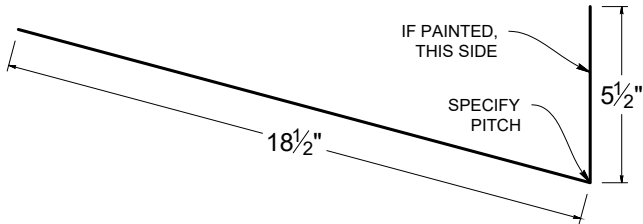

SCALE 1:6 S.O. 24" WEIGHT: 19.53 LBS.

OFFSET CLEAT
(MS100OC / MS150OC)

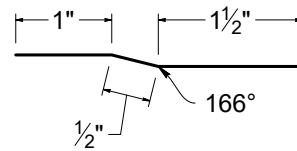

NON-VISIBLE /
SUB-FLASHING ARE NOT
PROVIDE IN SPECIFIC
COLORS UNLESS
SPECIFIED

SCALE 1:2 S.O. 3" WEIGHT: 2.5 LBS.

END DAM

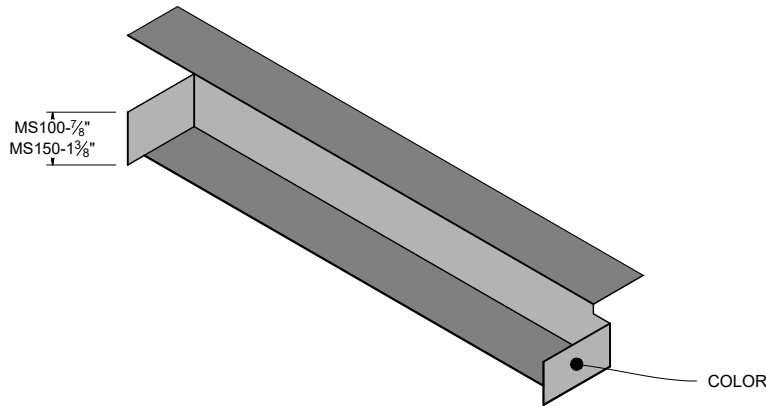

S.O. VARIES

WEIGHT: VARIES

SCALE 1:5

4" PERFORATED STRIP
(MS100PS / MS150PS)

NON-VISIBLE / SUB-FLASHING
ARE NOT PROVIDE IN SPECIFIC
COLORS UNLESS SPECIFIED

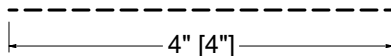

SCALE 1:2 S.O. 4" WEIGHT: 3.3 LBS.

PERFORATED VENT DRIP
(MS150PVD / MS100PVD)

NON-VISIBLE /
SUB-FLASHINGS
ARE NOT PROVIDED
IN SPECIFIC
COLORS UNLESS
SPECIFIED

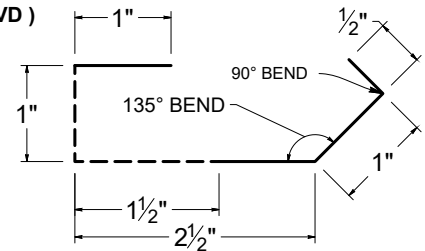

SCALE 1:2 S.O. 6" WEIGHT: 4.88 LBS.

REGLET
(MS100RF / MS150RF)

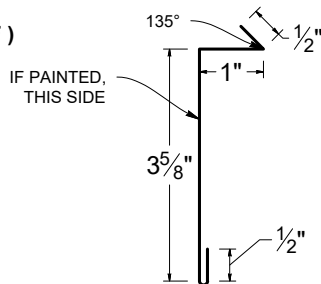

SCALE 1:3 S.O. 5.625" WEIGHT: 4.6 LBS.

ZEE CLOSURE
(MS100ZC / MS150ZC)

* HEIGHT ALLOWS FOR
3/8" DOUBLE BEAD BUTYL
TAPE. IF USING
CAULKING PLEASE
INQUIRE OF TMP REP

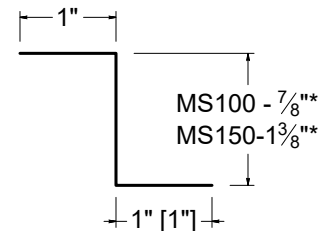

SCALE 1:2 S.O. 2.875" / 3.375" WEIGHT: 3 LBS.



Order Form

Inside Sale: _____

New Order Add-on Order Quote

PO #: _____ Date: _____

Sold To: _____

Order Contact: _____
Phone #: _____
Fax #: _____
 Agricultural Residential

Job Name: _____
Ship To: _____
 Will Call Delivery
Day: _____ **Delivery Date:** _____
 Commercial **Route:** _____

Standard Panels are in Bold font.

Panels with * need Pattern Choice:
 Ribs Striations Flat (Flat not available on StreamLine)
 Notched? Y/N Clip Relief? Y/N Sealant? Y/N
 Notched AND Tabbed? Y/N (REQUIRED together for EasyLock & StreamLine)
 Screw Concealer? Y/N (Standard for Ribs and Striations)

- PBR
- Marion "R" Panel
- Max Corr
- 2-1/2" Corrugated
- Classic 7/8" Corrugated
- GR-7
- HR-34
- T-3
- Tuff-Rib

- 12" Easy-Lock* ShadowLine** (circle): 1", or 1-1/2" 1/2" to 3" Reveal: _____
- 16" Easy-Lock*
- 16" StreamLine* 1"x12" SmoothWall**
- 1"x12" Lifetime Soffit**

- 15 5/8" Slim-Lock*
- 12" MS-200*
- 14" MS-200*
- 16" MS-200*
- 18" MS-200*
- 12" MS-150*
- 16" MS-150*
- 20" MS-150*
- 13" MS-100*
- 17" MS-100*
- Other Panel: _____

Color: _____
 Pitch: _____
 Gauge: _____
 Dmatch: _____
 Pallet: 10' 20' 30'
 12" Versa-Span*
 14" Versa-Span*
 16" Versa-Span*
 18" Versa-Span*
 14 5/8" T-Panel*

Panels with ** need Pattern Choice:
 Striations Flat 1 V-Groove 2 V-Grooves
 Perforated? (Available on Lifetime Soffit Only)

Panel & Flashing Items

*All Kynar Slim-Lock, Easy-Lock, Lifetime Soffit, SmoothWall, ShadowLine, T-Panel, Versa-Span, MS-100, MS-150, & MS-200 flashings are 10'
 *All ArmorTech StreamLine, T-3, Tuff Rib, GR7, PBR, HR-32, Marion "R", & Corrugated flashings are 12'6"

Quantity	Length	Item Description	Part #	Quantity	Length	Item Description	Part #

Forgetting Anything?
 Underlayment? Screws? Clips? Caulking? Closures?

Customer Name: _____ Job Name: _____

Gauge: _____ Color: _____ Status: Original New

Specify: Angles Color Side Dimensions Stretchout

SO _____

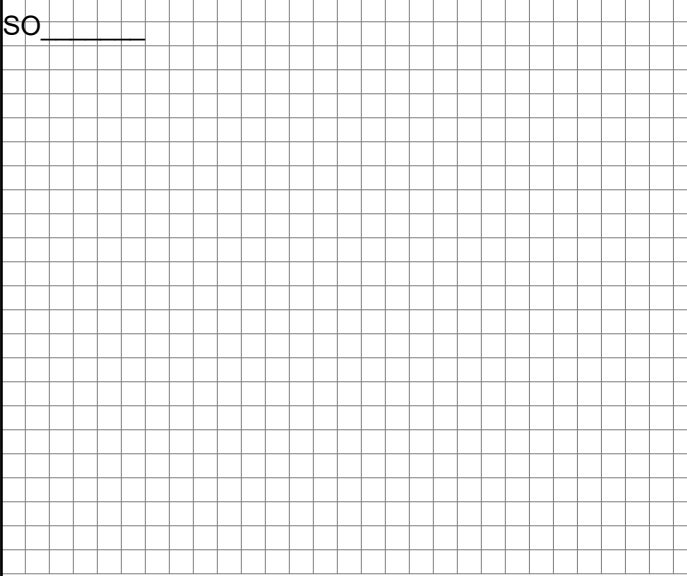

Dwg #: _____ Pitch: _____ # of Pieces: _____

Description: _____

Hems: Open Closed Slightly Open

SO _____

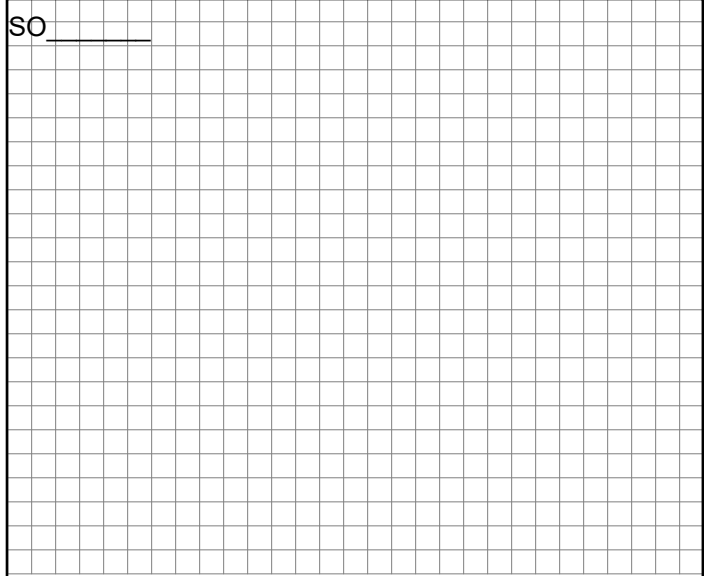

Dwg #: _____ Pitch: _____ # of Pieces: _____

Description: _____

Hems: Open Closed Slightly Open

SO _____

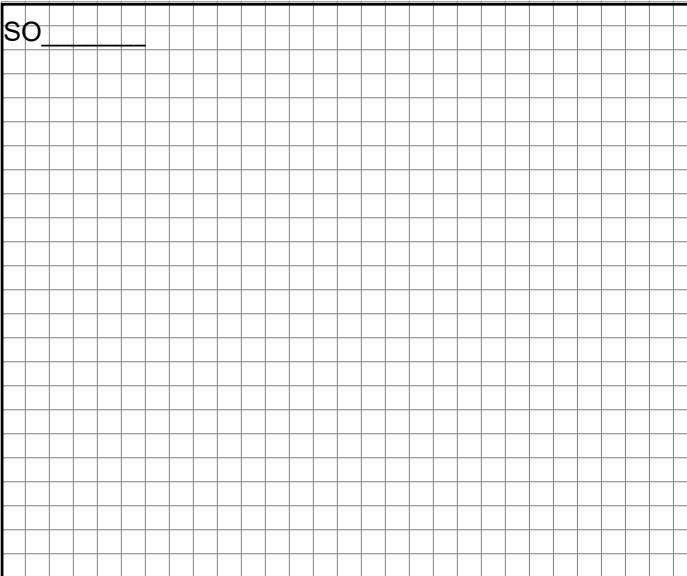

Dwg #: _____ Pitch: _____ # of Pieces: _____

Description: _____

Hems: Open Closed Slightly Open

SO _____

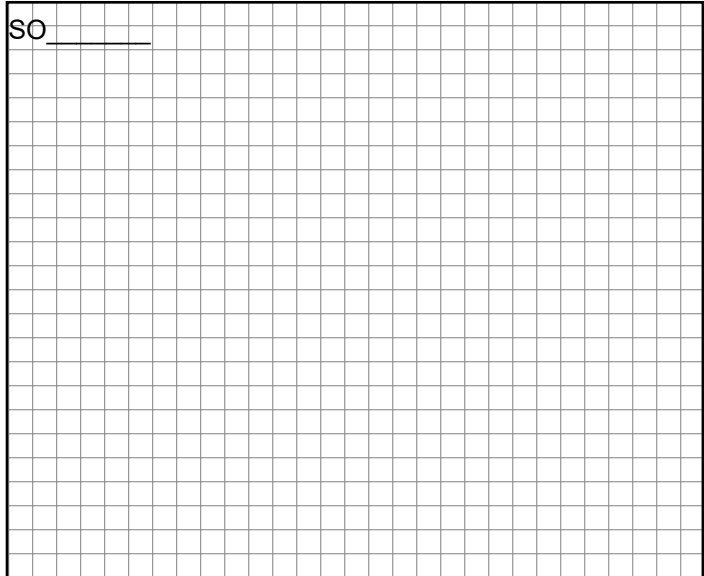

Dwg #: _____ Pitch: _____ # of Pieces: _____

Description: _____

Hems: Open Closed Slightly Open

Please provide a drawing for each flashing with precise measurements and angles

Fax to: 503-581-6877

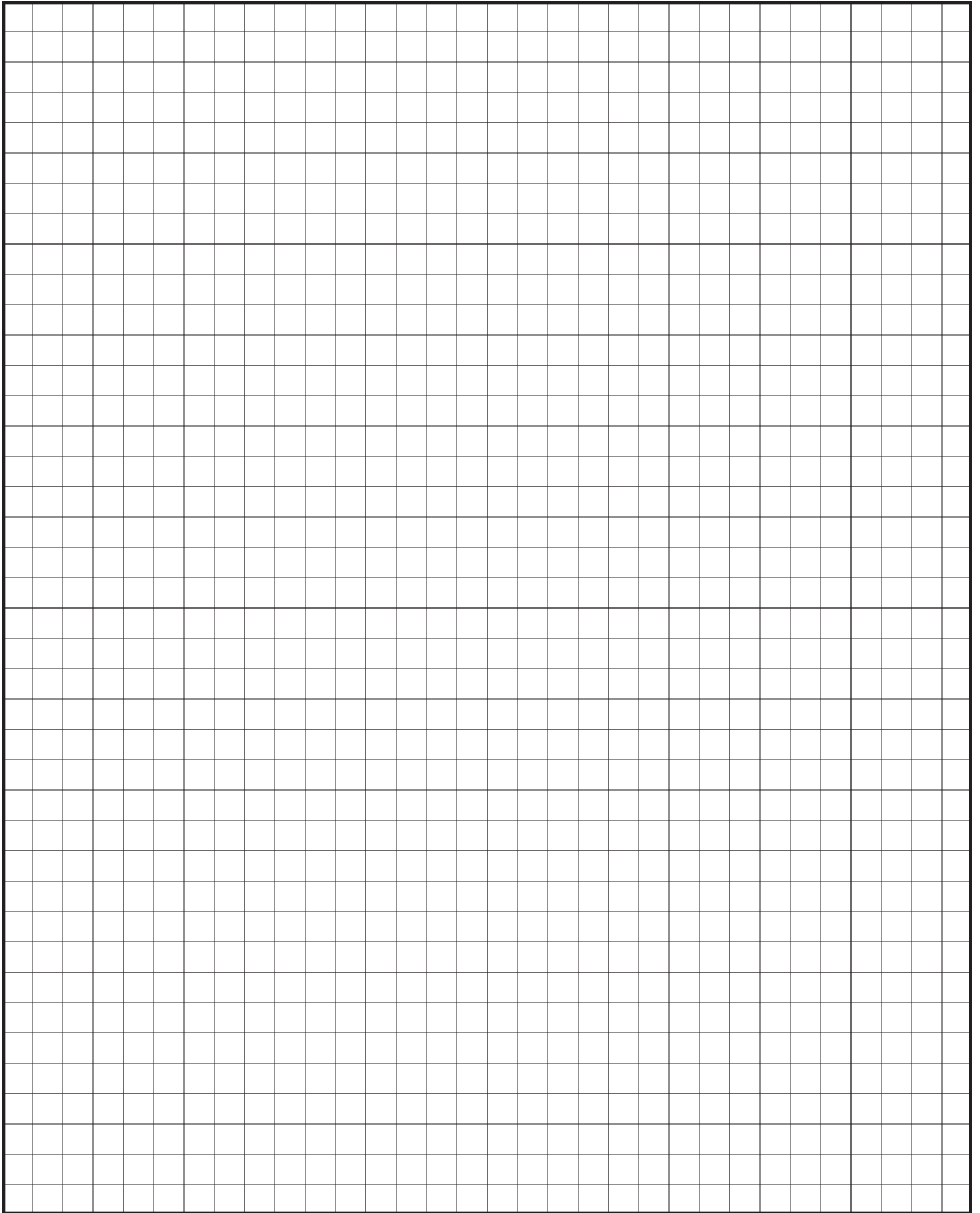

Customer Name: _____ Job Name: _____

Gauge: _____ Color: _____ Status: Original New

Specify: Angles Color Side Dimensions Stretchout

SO _____

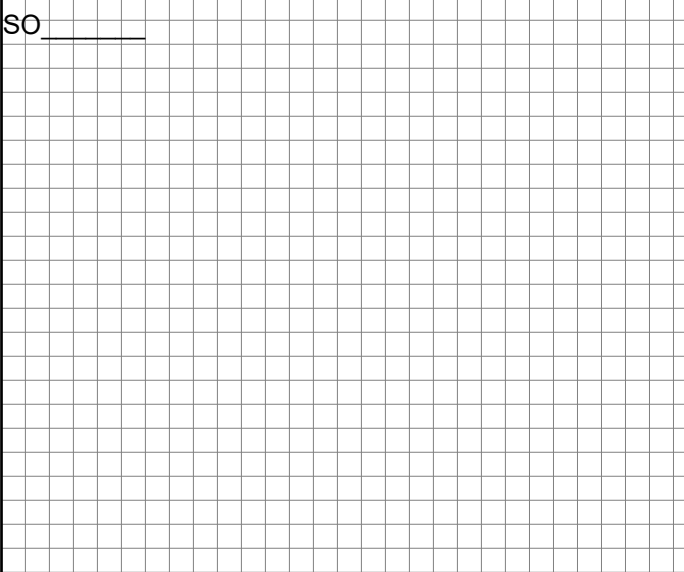

Dwg #: _____ Pitch: _____ # of Pieces: _____

Description: _____

Hems: Open Closed Slightly Open

SO _____

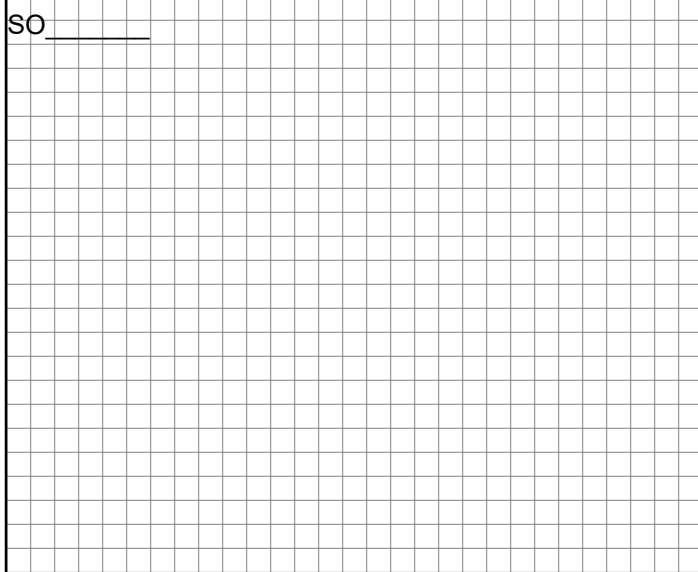

Dwg #: _____ Pitch: _____ # of Pieces: _____

Description: _____

Hems: Open Closed Slightly Open

SO _____

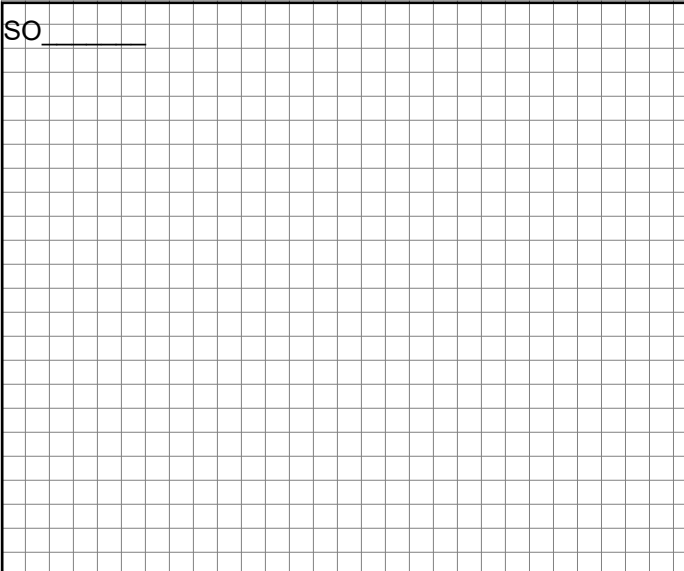

Dwg #: _____ Pitch: _____ # of Pieces: _____

Description: _____

Hems: Open Closed Slightly Open

SO _____

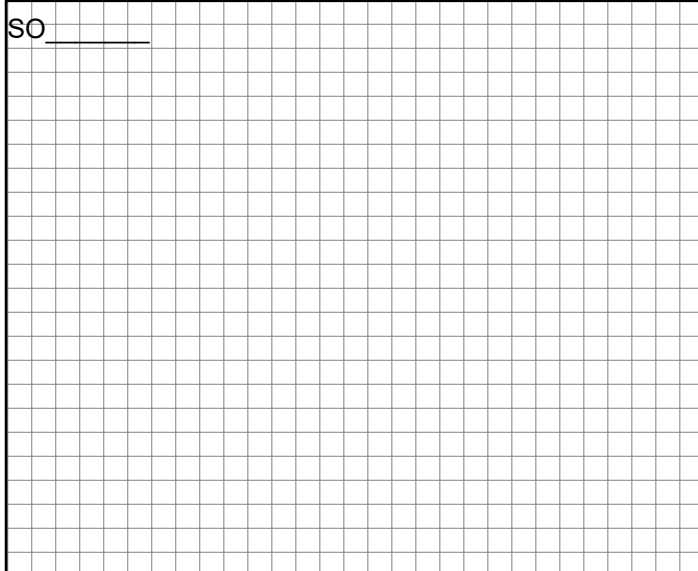

Dwg #: _____ Pitch: _____ # of Pieces: _____

Description: _____

Hems: Open Closed Slightly Open

Please provide a drawing for each flashing with precise measurements and angles
Fax to: 503-581-6877

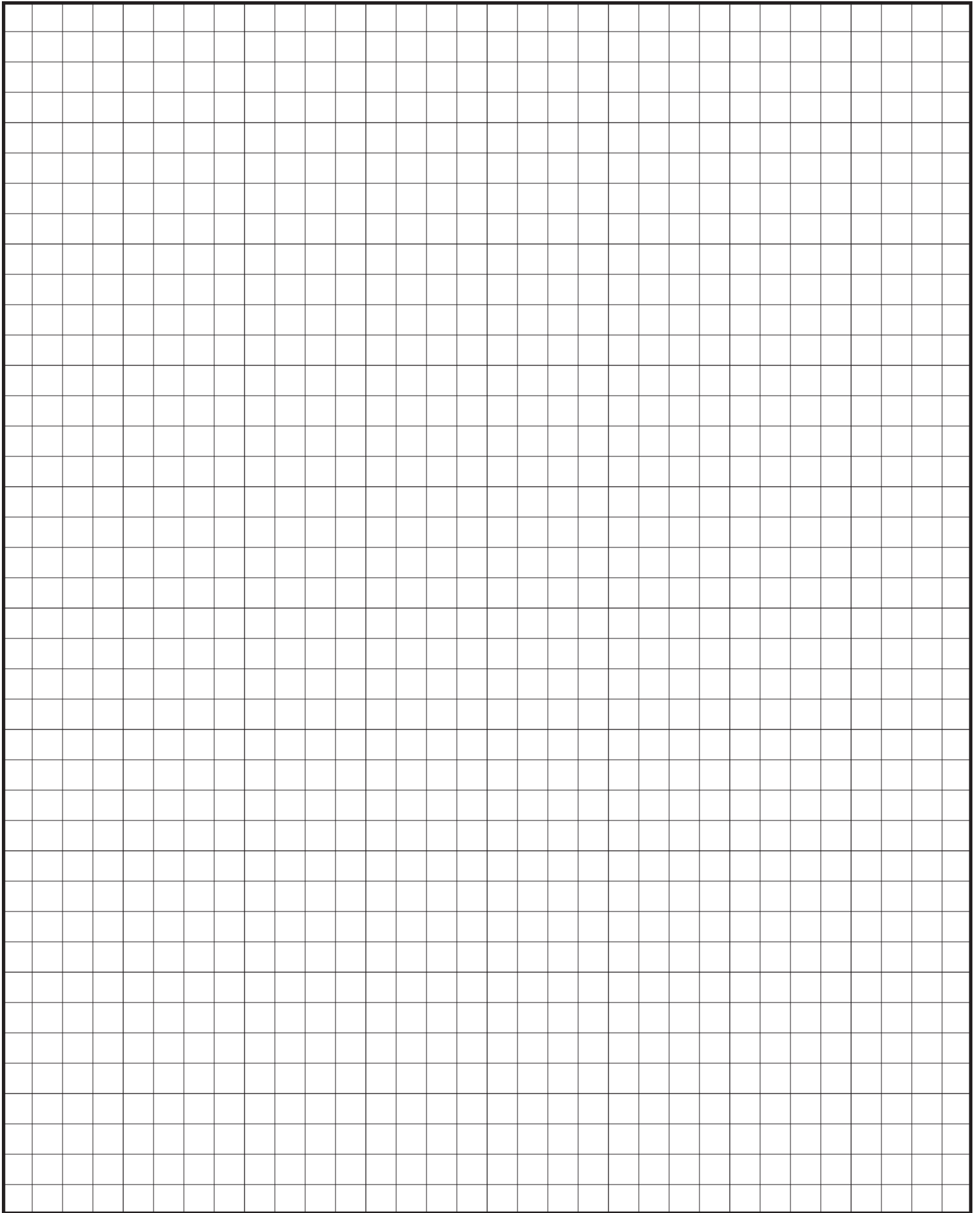



TAYLOR

METAL PRODUCTS

QUALITY PRODUCTS
EXCEPTIONAL SERVICE

SALEM BRANCH

4566 Ridge Dr. NE
Salem, OR 97301

Office: 503-581-8338
Toll Free: 1-800-574-1388
Fax: 503-581-6877

SACRAMENTO BRANCH

5711 Perrin Ave
McClellan, CA 95652

Office: 916-318-8844
Toll Free: 1-800-574-1388
Fax: 916-993-4123

AUBURN BRANCH

2601 C St. SW
Auburn, WA 98001

Office: 206-900-9923
Toll Free: 1-800-574-1388
Fax: 253-804-3545

RIVERSIDE BRANCH

4880 Felspar St.
Riverside, CA 92509

Office: 323-407-7457
Toll Free: 1-877-504-1594

SPOKANE BRANCH

1010 N Nelson St
Spokane, WA 99202

Office: 509-535-8667
Toll Free: 800-238-4057
Fax: 509-535-8682