

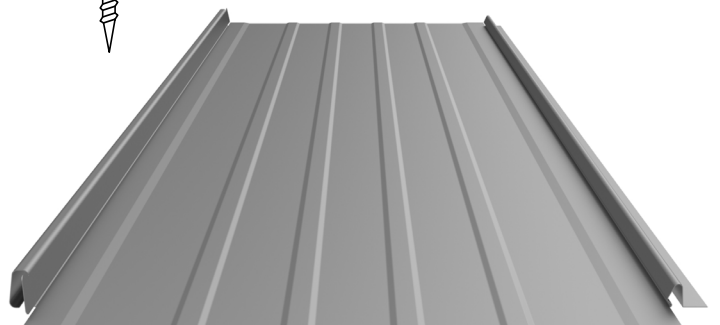

# ROLLED STEEL PRODUCTS

*a Taylor Metal Company*

## Easy-Lock™ Installation Guide

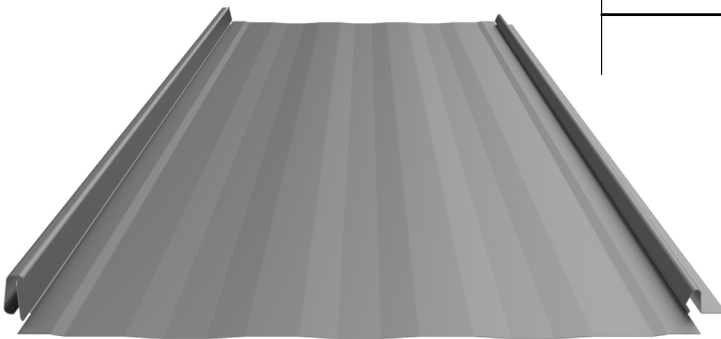
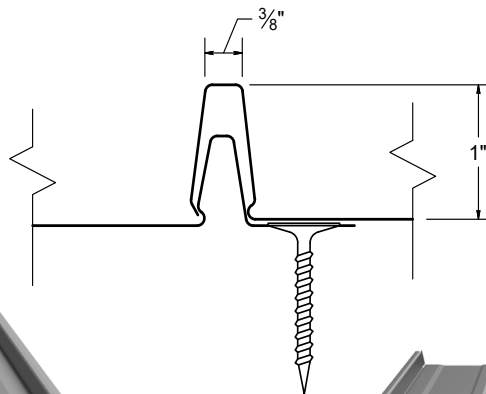





● Panel Specifications ..... 4-5	● Vented Ridge Detail ..... 22
● Introduction ..... 6	● Valley - High Pitch Detail ..... 23
● Handling & Storage ..... 7	● Valley - Low Pitch Detail ..... 24
● Taylor Delivery Fleet ..... 8	● Box Gable Detail ..... 25
● Delivery & Will Call/Loading ..... 9	● Prow Detail ..... 26
● Tools & Equipment ..... 10	● Sidewall Detail ..... 27
● Fasteners ..... 11	● Peak Flashing Detail ..... 28
● Roof Preparation ..... 12	● Pitch Change Detail ..... 29
● Roof Layout ..... 13-14	● Hemmed Endwall Detail ..... 30
● Reversing Strip ..... 15	● Vented Endwall Detail ..... 31
● Panel Preparation ..... 16	● End Dam Detail ..... 32
● Panel Installation ..... 17	● Eave to Gable Transition ..... 33-35
● Low Pitch Eave Detail ..... 18	● Skylight/Chimney ..... 36-38
● Hook Eave Detail ..... 19	● Pipe Penetration Applications ... 39-42
● Hook Eave with Gutter Detail ..... 20	● Standard Flashings ..... 43-49
● Hip/Ridge Detail ..... 21	● Order Form ..... 50

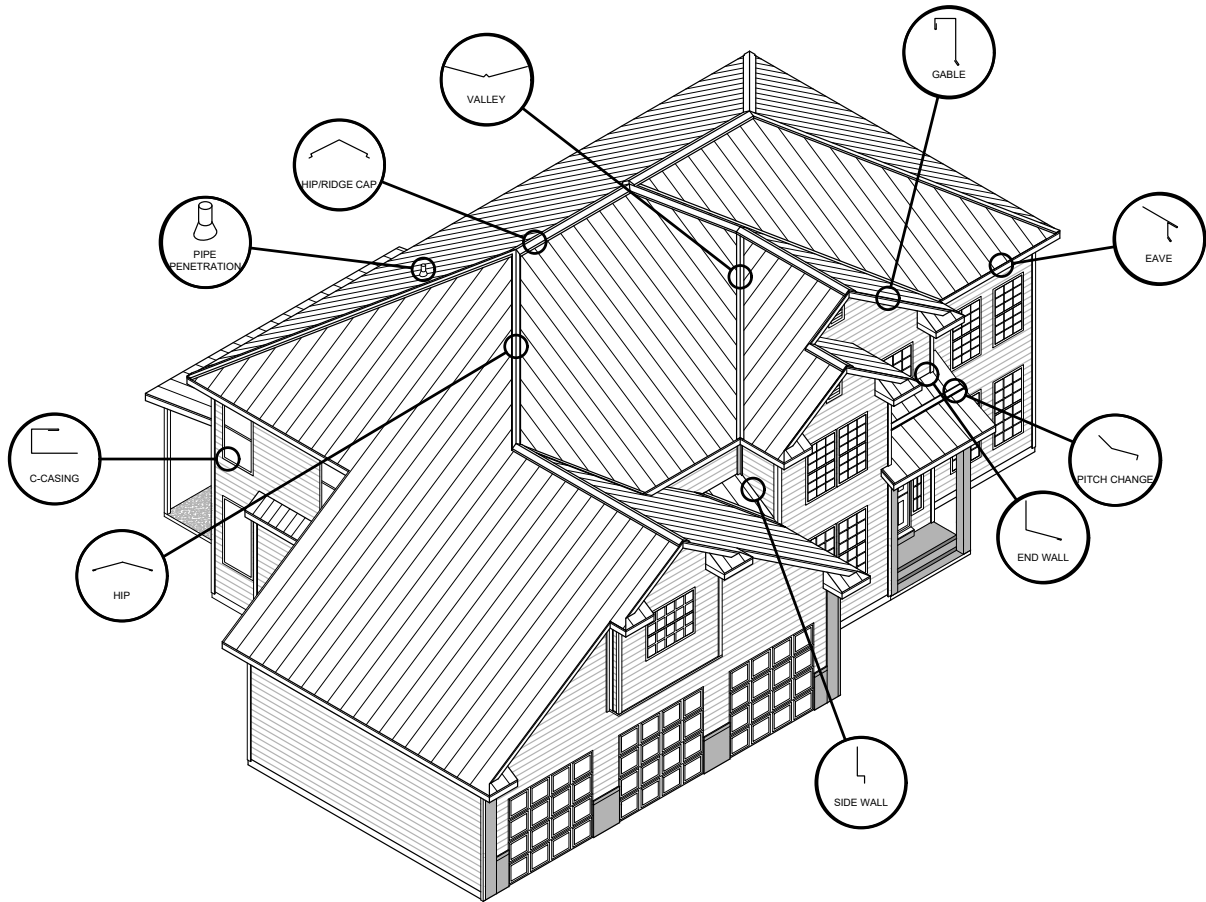

12" and 16" coverage options

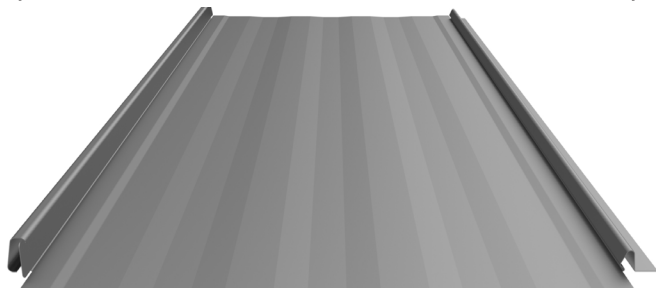

**STRIATIONS**

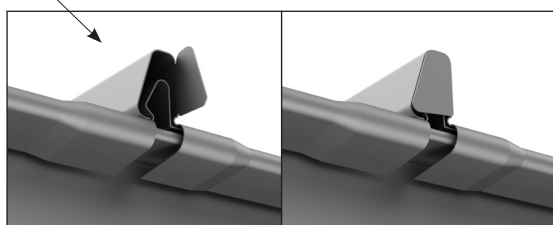

Tabbing feature can help minimize debris from entering in between seams, and gives a more finished appearance.

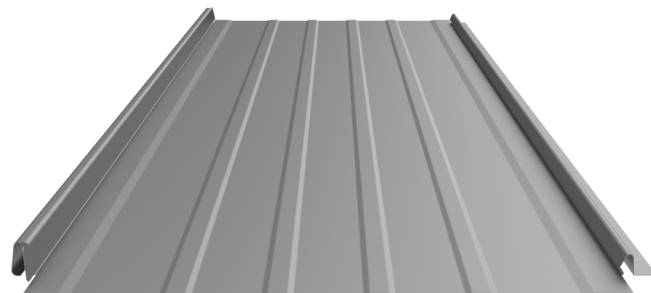

**ACCENT RIBS**

3 Accent ribs for 12" panel  
4 Accent ribs for 16" panel  
(16" panel shown)

**LOCK SEAM DETAIL    REVERSE LAP DETAIL**

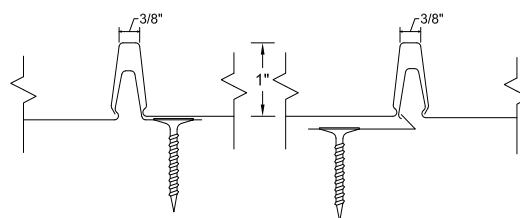

### KEY FEATURES

- 12" and 16" coverage options
- 26, 24 & 22 Tru-Gauge™ and .032" Aluminum
- 16 & 20 oz. Copper (*Please inquire*)
- Factory-notched and tabbed panels available
- Vertical interlocking application: allows installation from both directions starting at any location
- Patented no-siphon lock seam
- 1" vertical rib with 3/8" flat top for ease of flashing attachment
- Concealed fasteners: fasteners cannot leak
- Pre-slotted fastener flange: allows expansion & contraction of panel (high wind clips available for panel lengths over 35')
- 3:12 minimum pitch recommended (*For lower pitches, please inquire*)
- Standard panel lengths 4' to 35' - not notched  
Standard panel lengths 1' to 35' - notched (*For longer panels, please inquire*)
- Panel options: Striations, Accent Ribs, and Flat Pan

### TESTING

-  Code compliance UL Evaluation Report UL ER #25913-01
- UL Construction No. 529
- UL 580 Class 90 - Wind Uplift
- UL 790 Class A (ASTM E108) - Fire rated
- UL 2218 Class 4 - Impact (hail) rated
- ASTM A653/A924 - G90 Galvanized
- ASTM A792 - Zinalume/Galvalume AZ-50/55
- ASTM B209 - Aluminum Substrate



The Easy-Lock™ Standing Seam is the only metal roofing panel with a patented no-siphon dry lock seam, with a unique reversing feature to allow installation of panels from both directions starting at any location. The panel is designed with softer, less industrial lines to provide an architecturally pleasing appearance.

## MATERIAL SPECIFICATIONS

- 26 gauge Kynar 500® Painted Steel  
G-90 Galvanized or AZ-50
- 24 gauge Kynar 500® Painted Steel  
G-90 Galvanized or AZ-50
- 24 & 22 gauge Zincolume® Plus AZ-55  
(No finish warranty – 25 yr. perforation warranty)
- ▲ 22 gauge Kynar 500® Painted Steel  
G-90 Galvanized or AZ-50
- ◆ .032" Kynar 500® Painted Aluminum
- 22 gauge Rusteel Plus™ (A606)
- 16 and 20 oz. Copper  
(Please inquire)
- Kynar 500® and substrate testing data available  
(See website)

## FINISHES

- 21 Standard Colors, 5 Metallic Colors and 4 Specialized Materials
- Kynar 500® Paint System - the ultimate in exterior durability and color retention
- “Cool” color pigments are specially designed to reflect infrared light, reducing heat gain to dwelling, and conform with ENERGY STAR® criteria
- Superior quality, two coat, 70% resin finish, applied at a 1 mil. thickness
- 40 year residential paint warranty
- 20 and 30 year commercial paint warranty: Contact your sales rep. for warranty specifications

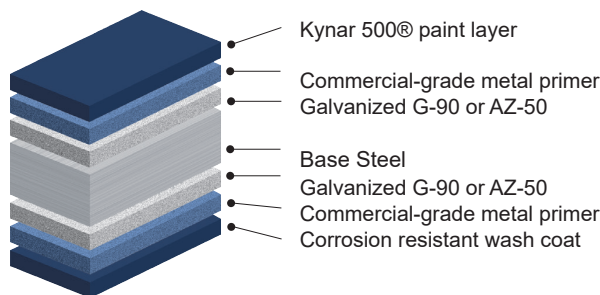

## STANDARD COOL KYNAR 500® COLORS

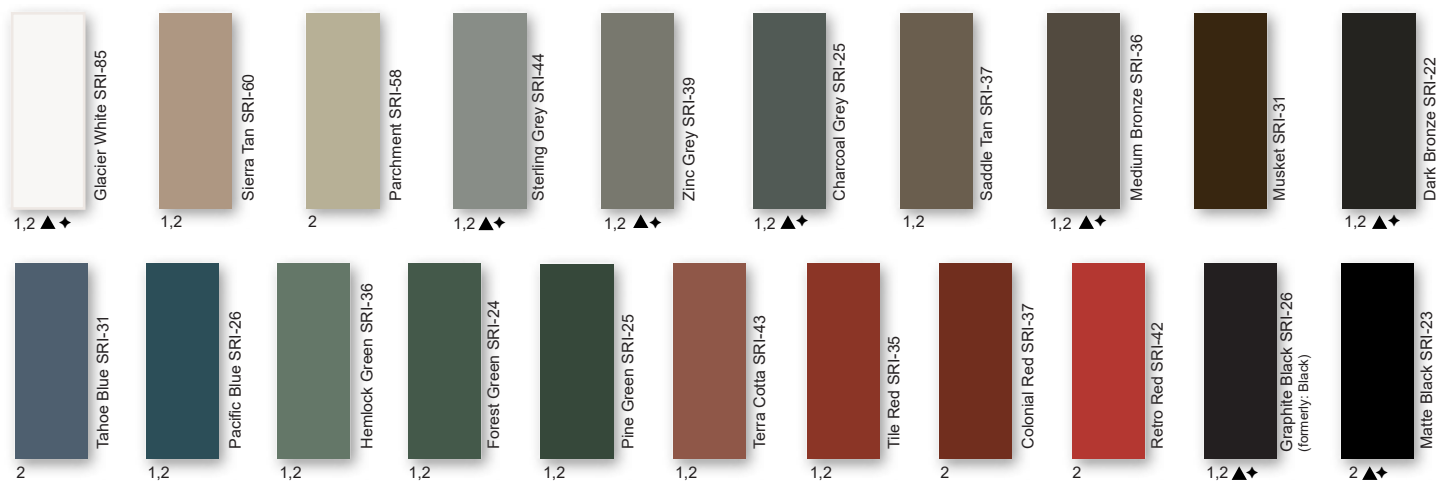

## PREMIUM METALLIC COOL KYNAR® COLORS

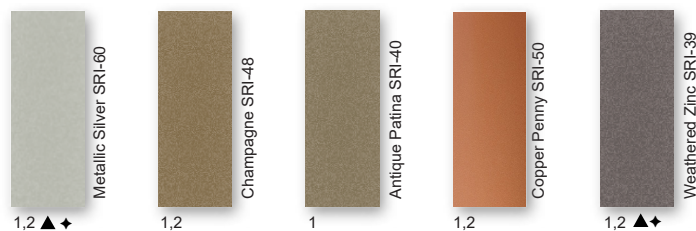

## SPECIALIZED MATERIAL

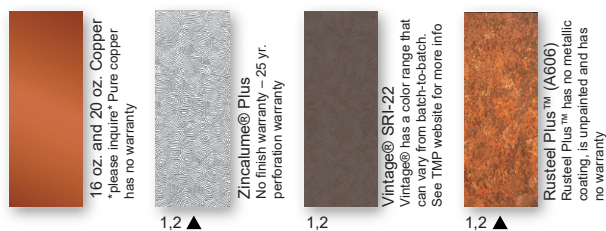

These printed chips provide a close representation of the colors.

Metal samples are available upon request. Coatings are low gloss 10-15% sheen.  
SRI = Solar Reflective Index. SRI values listed above are in accordance with ASTM E 1890 and are based on actual testing.\*\*\*Oil canning is not a cause for material rejection\*\*\*





RSP (a Taylor Metal Products Company), Easy-Lock™ Standing Seam roofing product is designed for residential and light commercial applications, however it is not limited to these uses.

The Easy-Lock™ Standing Seam concealed fastener roofing system is an architectural roofing system and is designed to be weather tight, attractive, easy to install and to provide long life.

These installation instructions are intended to offer suggested application procedures for common building construction. No attempt is made to provide installation details for every application or possible use.

Please contact RSP (a Taylor Metal Products Company) for use of custom flashing details as they pertain to specific conditions or to discuss a specific project.

Conformity to local building codes, details for specific applications, and use of safety and health procedures is the sole responsibility of the installer.

RSP (a Taylor Metal Products Company), assumes no liability for the improper installation of the Easy-Lock™ panel nor for any personal injury or property damage that may occur with the product's use.

*\*Oil Canning - All light gauge metals can display waviness often referred to as "oil canning." This is caused by steel mill tolerances, substrate variation and relative reflectivity. "Oil canning" is an inherent characteristic of steel products, not a defect, and is not a cause for material rejection.*



## Handling

Handle materials with care when off loading or moving materials to avoid damage to panels or flashings. Long panels may require two or more pick-up points, properly spaced to avoid damaging panels. Plan ahead. Contact RSP (a Taylor Metal Products Company) for recommendations on handling/hoisting long panels.

Wear clean cotton gloves when handling copper or unpainted Zincolume® to avoid leaving fingerprints and smudges. While finger-prints or smudges will not harm the material, they will temporarily leave markings on the material until the material weathers.

Wear clean, soft-soled shoes when walking on roofing panels to avoid damage to the painted finish. Take care that sand, gravel, dirt etc. sticking to your shoes is not carried onto the roof, scratching or otherwise damaging the finish on the roofing material.

Walking on asphalt impregnated felt paper, especially on a hot day, can cause the asphalt to stick to your shoes and be tracked onto the roofing material. Do not walk on major ribs of panels. Do not walk on panels that have not been completely installed.

Take care when painting to avoid getting over spray on the roofing material. Remember that wind can carry paint particles some distance. Over spray can cause the finish of the roofing material to look dull and may void your warranty.

Do not allow panels to contact preservative-treated lumber. Water and ice shield material is effective in preventing a corrosive reaction between steel products and pressure-treated lumber.

## Storage

Store the panels, flashings, and accessories in a dry, well ventilated area, on level ground. Slightly elevate one end of bundles to allow drainage of wet materials. Support panels with blocks throughout escalation in elevation to prevent permanent deformation. If covering, allow ventilation around the panels.

Protect panels against standing water and condensation between adjacent surfaces. If panels become wet, immediately separate sheets, wipe dry with clean cloth, and keep sheets separate for air-drying.

Painted metal roofing panels will have a clear plastic film applied to the lower rib of the panel to protect the seam during transportation and handling. Flashing and flat sheet may have a plastic film for protection. Remove this film prior to installation of the panels.

Products with film should not be stored in direct sunlight or under other UV source, and should not be left in extreme heat or cold for long periods.

Secure materials on the ground or roof to prevent winds from moving the materials, especially when leaving the site. Wind-blown materials may cause damage to the material, property or persons. Avoid installing panels in windy conditions.

Safety considerations are the responsibility of the installer and their crew. Be sure to **use common sense** and accepted industry standard safety practices when installing roofing materials. Always use proper safety equipment and attire to minimize risk of cuts or other injuries.

# Taylor Delivery Fleet



**ROLLED STEEL PRODUCTS**  
*a Taylor Metal Company*

## Delivery Fleet

RSP (a Taylor Metal Products Company) prides itself with quick lead times delivered with our fleet of semi trucks. Our fleet of trucks are owned and operated by RSP. All of our drivers are RSP employees, so when your truck rolls in to deliver, you are dealing with RSP.

Expect consistent and exceptional service with short lead times. The inhouse fleet allows for efficient and cost-effective delivery.



Mounted on the rear of our semitrailer, the trailer-mounted "piggy-back" forklift will accompany you right to your place of use, opening up unprecedented possibilities in terms of transportation. It can travel sideways, carrying panels up to 40' long, allowing delivery in locations that would typically be considered impossible to reach.

Save time and effort while avoiding potential loading and transport issues; have experienced RSP personnel deliver and unload your order.







## Delivery

We will make every attempt to deliver material to the desired location. We may be unable to gain access on tight corners or steep terrain. If the site is deemed inaccessible by our driver, the customer may choose an alternate delivery site within a reasonable proximity. If we are unable to make the alternate delivery, additional charges may be assessed.

The customer is responsible for:

- Determining adequate access for delivery ahead of time.
- Meeting the delivery at the agreed upon time.
- Providing adequate resources (1-4 people as needed) for off loading materials.  
***A charge of \$100 per hour may be added for deliveries that go beyond their allotted time.***
- Checking the shipment at the time of delivery.
- Verifying material quantities against the shipping/packing list.
- Noting any damage or discrepancies upon the paper work at the time of delivery and notifying RSP (a Taylor Metal Products Company) within 48 hours of delivery.

Delivery times are usually scheduled one day in advance. RSP (a Taylor Metal Products Company) will make every effort to make the delivery at the scheduled time. Please be aware that there may be conditions beyond our control such as traffic, mechanical failures, road closures, etc. which may affect our schedule. If a delay is expected, you will be notified in advance of delivery.

## Will Call/Loading

Flatbed trailers and trucks are best suited to transport metal roofing materials. These can be loaded from the side with a forklift and tied down in a safe and secure manner.

We are not able to load materials onto vehicles and/or trailers which are not suitable or may be hazardous to load. Please be aware that if we find a vehicle to be inappropriate, we reserve the right to refuse to load your order.

Unacceptable examples include: boat trailers, vans, buses, motor homes, campers and box trailers. Pickup racks which do not have sufficient supports for the weight or are not long enough to support bundles are also unacceptable.

RSP (a Taylor Metal Products Company) is **not** responsible to tie down loads nor do we provide any tie down materials. Please bring tie downs to secure your load (string or twine are **not** acceptable for this purpose).

**Consider having your order delivered on one of our trucks with a piggy back forklift.**





## The following tools/safety equipment may be used for proper installation:

- Screw Gun: Clutch type, variable torque, cordless screw guns will give the best results.
  - Extra batteries
  - Bit holder - magnetic
  - #2 square drive bits or philips drive bits (for panel screws)
  - 1/4" Hex head - magnetic - bit driver (for woodfast flashing screws)
  - 1/8" drill bit (for rivets & pre-drilling fastener holes)
  - Belt & holster (keeps all the above tools safely on your hip)

### Cutting Tools:

- Cutters/Offset (curved jaw) left & right (for precision cutting, long cuts)
- Snips (straight jaw) left & right (for short cuts & circular cuts)
- Electric Shears (aids in long panel rips)

**CAUTION: POWER SAWS MAY CAUSE PANEL DAMAGE!**

**RSP recommends cutting panels and flashings with tin snips or shears.**

**We do NOT recommend the use of saw blades or abrasive wheels - use may void warranties and reduce longevity, especially in marine environments.**





***WARNING : Filings, debris and metal chips must be wiped off panels each day to avoid corroding the panels and causing rust specks or stains. Water can cause non-finished metal shaving to bind to panels after rust develops damaging panels. Failure to properly install panels and remove debris may void the warranty.***

## Other Tools:

- DeBurring Tool
- Hole Punch (for pre-punching holes in metal)
- Rubber Mallet - SoftType (for adjusting panels & flashings)
- Quick Square, Framing Square & Bevel Square (aids in squaring flashings & panels)
- Duck Bill Vise Grips/Pliers (for various bending)
- Upender Tools (used for panel-prep, available at RSP)
- Tape Measures
- Rivet Tool (for riveting flashings)
- Marking pen or grease pencil
- Chalk Line (for marking long panel rips and to align panels)
- Protective gloves to protect hands
- Cotton gloves for working with copper (to protect against fingerprints on finish)
- Ear plugs
- Safety harness kit

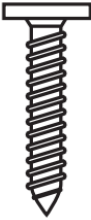
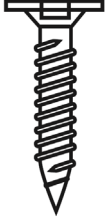

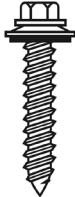
**TMP recommends the following fasteners:**

FASTENER	DESCRIPTION	USE
	<b>Pancake Head, Sharp point</b> #10 x 1" #2 Phillips Head	The pancake head screw is recommended for panel attachment and is a concealed fastener.
	<b>Waferhead Srew, Sharp point</b> #9-16 x 1" #2 Phillips/Square Drive #9-16 x 1-1/2" #2 Square Drive	Waferhead screws are used for attaching the panels to a wood deck or substrate. They are concealed fasteners.
	<b>Lath Head Screw, Sharp Point</b> #8 x 9/16"	While generally not recommended for most applications, this concealed fastener is useful for areas where a longer fastener will penetrate the substrate and exhibit an objectionable appearance, such as exposed overhangs. The pull out rating for this fastener is less than the waferhead, so these fasteners need to be placed more often.
	<b>Woodfast Screw, Sharp Point</b> #9-16 x 1 1/4" Hex Drive- Color Match #9-16 x 1/2" 1/4"	Woodfast screws are recommended for attaching metal to wood in some cases metal to metal.
	<b>Stitch Screw, Sharp Point</b> #12 x 3/4" 1/4" Hex Drive-Color Match	Stitch Screws are used to attach metal to metal such as lap joints in flashing. They can be used interchangeably with rivets.
	<b>Rivets</b> #43 (1/8" x 1/8") Stainless Steel rivet Color Matched or non-painted.	Rivets are used to attach metal to metal such as lap joints in flashing.

# Roof Preparation



**ROLLED STEEL PRODUCTS**  
*a Taylor Metal Company*

## New Construction

RSP (a Taylor Metal Products Company) Easy-Lock™ Standing Seam roofing products can be installed for either new or re-roofing applications.

We recommend installing the Easy-Lock™ Standing Seam over a rigid continuous substrate such as plywood sheathing or decking. We recommend that the plywood be 15/32" or thicker or 22 ga. steel deck. For best results the substrate should be smooth, flat and free of debris.

Cover the entire roof area with 30 lb. ASTM rated felt paper. Apply the felt by rolling it out horizontally across the roof starting at the eave. Allow a 3" overlap for each course.

Lap end joints 6". Maintain the rule of keeping uphill courses lapped on top of downhill courses of felt. Tears and cuts should be replaced with new felt or repaired with roofing lap cement.

To prevent bonding between the copper and roofing felt, a layer of smooth building paper or a rosin sized slip sheet should be laid over the felt before installing the copper roofing.

## Re-Roofing

The Easy-Lock™ Standing Seam can be installed with felt over most existing asphalt, composition, fiberglass shingles or rolled roofing. Tile, gravel, wood shingles/shake, metal or any other type of roofing material should be removed to the bare sheathing. Inspect the substrate for damage or rot and replace sheathing as necessary. Apply the underlayment as described above.

Consider the following when installing the metal roofing over existing roofing materials:

- **Building Codes:** Local building codes will typically limit the number of layers of roofing allowed. Check with your agency.
- **Solid Fastening:** Check the condition of the substrate. Damaged or rotted plywood or decking will not provide for secure fastening. Repair or replace damaged or rotted substrates.
- **Appearance:** Irregular substrates may affect the overall appearance of the metal roofing product. Panel deformation may occur, however, product integrity will not be affected.

- **Roof surface:** Any warped or loose shingles must be nailed down along with any protruding nail heads. Remove all moss and other debris, including existing starter strips. Cut off all overhanging shingles and remove hip and ridge caps.
- **Ventilation:** Trapped moisture can cause premature failure of the metal roofing product as well as substrate, insulation etc. Provide adequate ventilation and appropriate moisture protection.

## Ventilation

Proper ventilation is necessary for full roof life. Check local codes for venting requirements.

To provide for ridge and/or hip ventilation, remove (for retrofit) or leave out (for new construction) 2" of sheathing on both sides of the ridge center. Cover opening with flyscreen and secure the flyscreen with staples. Apply felt paper up to the edge of opening as explained in "Underlayment" section.

RSP (a Taylor Metal Products Company) recommends allowing ventilation between the outer roof deck and the insulation. Lack of ventilation may trap moisture. The rib of the panel is not a source of ventilation for the area beneath the roofing panels.

## Insulation

Check with your design professional or insulation consultant for applications or design details. Also check local building codes to ensure compliance.

## Touch-Up Paint

Most of the time touch-up paint is supplied in spray cans. Spray cans are useful for painting large areas such as downspouts, pipe flashings, and other pre-existing areas.

**Scratches and scuffs in the finish should be touched-up but not sprayed.** The paint should be well mixed and sprayed into a small container, then applied to scratches with a very fine brush or toothpick, just filling in the scratch. If the area is sprayed over, the differences in the chemical makeup will likely cause the touch-up paint to fade differently than the baked-on finish and cause a blotchy appearance over time.

Paint pens are offered in most Kynar® colors and work best for covering minor scratches, please inquire for color options. Paint pens not available for ArmorTech™ panels.



It is important to get the roofing panels installed straight and you can't always depend on the gable/rake edge to be straight. After the underlayment has been applied you must now lay out an alignment line at the gable edge to align your first panel. You can use either of the following methods to check the gable edge to ensure the first panel gets started straight.

## Method #1: 3-4-5 Triangle

The first method utilizes the 3-4-5 triangle method. After the underlayment has been applied, you must now lay out a grid line along the gable edge to align your first panel. Here we are using a 3-4-5 triangle in increments of 9'-12'-15' (e.g.  $3 \times 3 = 9$ ,  $3 \times 4 = 12$ ,  $3 \times 5 = 15$ ). For longer panels use larger multipliers ( $5 \times 3 = 15$ ,  $5 \times 4 = 20$ ,  $5 \times 5 = 25$ ).

**Step 1:** Snap an alignment line 2 feet from the eave.

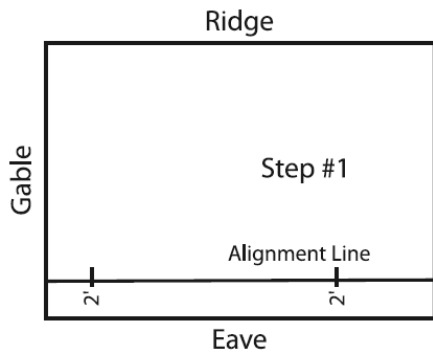

**Step 2:** Start from a point (datum) on the alignment line 1/4" to 1/2" from the left (or right depending on which edge you're starting from). Establish a 12' arc from datum point.

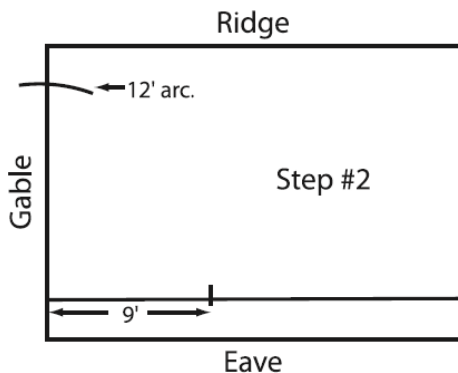

**Step 3:** Measure 9 feet from the datum point along the alignment line and establish a reference point there.

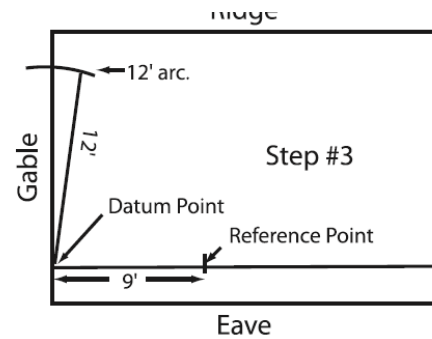

**Step 4:** From the reference point make a 15-foot arc to intersect the 12-foot arc. Snap a chalk line from the intersection point to the datum point. You now have a straight edge to align your first panel along the gable.

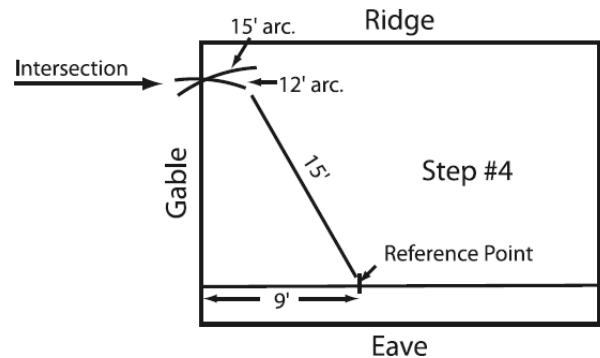

**Step 5:** If you have valleys: Since your underlayment will cover the true center line of your valleys, snap lines at these areas for aligning valley flashings.

## Method #2: Framing Square

The second method utilizes a framing square. Begin by stretching a string line from corner to corner at the eave edge. After the eave flashings are installed, lay down your first panel and square it at the eave using a framing square along the screw flange edge of the panel and squaring to the string line. Once square, secure alignment panel by putting one panel screw in at the bottom and at the top.

If a gable roof, check for the gable side of the pan to be no more than  $\frac{3}{8}$ " off square. The standard gable flashing will compensate up to  $\frac{3}{8}$ ". If more than  $\frac{3}{8}$ ", a compensating gable flashing will need to be used.

Another method is to rip the first panel at the correct angle and to up-end the ripped edge 1" at 90 degrees and use the standard gable flashing. It may be required to rip the last panel. For extreme out of square conditions, consider using a Prow Flashing.

## Prow Roofs

For a prow roof, use the same procedure above to square the first panel. Go to the top and measure the distance from the prow side of the first full panel to the top of the prow edge. (The prow flashing should be installed first; allow for 2" between the prow pan up-leg and the rib of the first full panel).

For example, if your measurement was 3' - make a pencil mark on the framing square for this measurement.

It is critical to maintain and square with the eave. Snap a chalk line from the top mark to the bottom mark. This will be the actual line you will set your first prow panel on. Also, it will give you the angle required to rip your first, second and third prow panels.

Install the first two prow panels and remove the first full-length panel before installing the third prow panel. If you're accurate on your squaring, cuts and alignment, your first full-length panel will be square to the eave line. (See (a) Dotted line is 2" gap.)

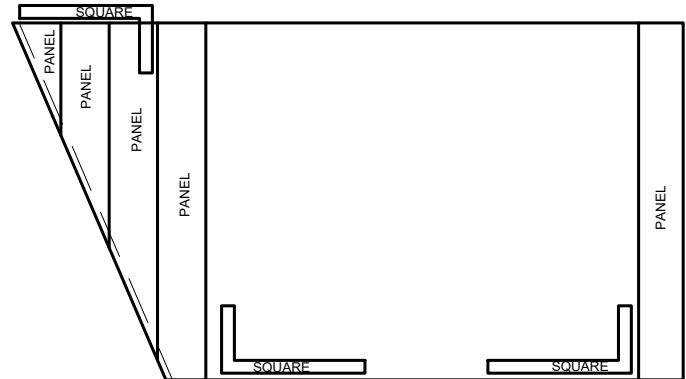

## Hip Roofs

Hip roofs present some challenges to panel alignment. The easiest method of aligning panels on a hip roof is to start in the center of the roof area and use the "Reversing Strip" (see page 13) to install the panels starting at center and installing panels in both directions (left & right).

Use either method of panel alignment to be sure the panels are straight and centered. Position the reversing strip at the center point and fasten into place. Then install the panels as indicated. Incidentally, you can also start the panels at center on a gable roof and work both directions.

Alternately you can align panels on a hip roof by starting with a longer panel (5' to 7') in length. Place the panel in the appropriate spot (usually 5' to 7') from the left or the right and use either method of aligning the panels to get a straight line to work from. Install this panel, and then work back to install the shorter panels and then the rest of the panels as usual.



**\*Reversing Strip suitable for use with Easy-Lock & StreamLine™ panels ONLY.**

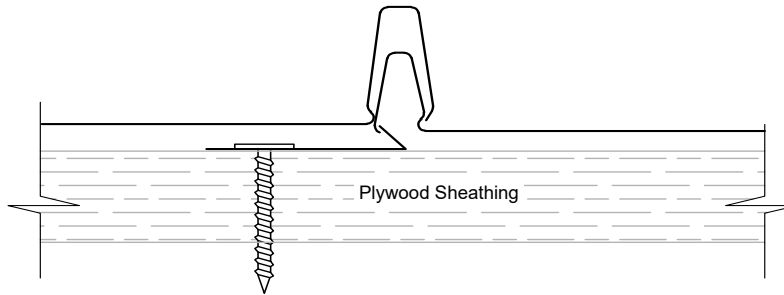

The reversing strip allows the Easy-Lock panels to be installed working both left and right. The reversing strip is most commonly used on hip roof applications although it can be used on other roof styles.

**Step 2:** Place a panel of the appropriate length on the roof and hook the lock lip of the panel (located on the upper/female rib) to the lip of the reversing strip. See (b)

Pull the panel so it fits tightly into reversing strip and fasten the panel to the sheathing with waferhead screws.

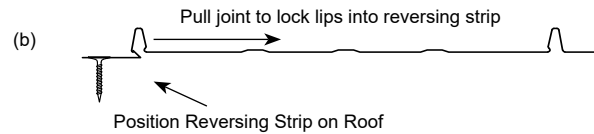
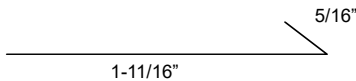

## Reversing Strip Application

**Step 1:** Locate the center of the roof section you are working on. Use 3-4-5 Triangle or Framing Square Method. See (a)

Snap a straight line on the mark perpendicular to the eave line. It is important that the line is straight, so that the panels will be straight.

**Step 3:** Position the next panel so that the female rib is over the female rib of the previous panel laying the opposite direction. Press down until the panel is locked onto the previous panel. Fasten that panel in place.

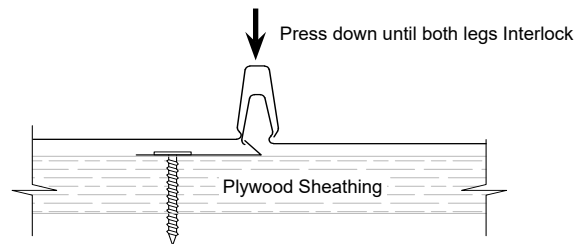
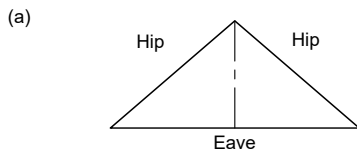

Position the turned edge of the reversing strip along the center-line and fasten to the sheathing every 18" to 24" with a waferhead screw. It won't matter which direction the strip faces.

**Caution:** We do not recommend reversing panels on the same pitch when using metallic colors (i.e. weathered zinc or copper penny) or Zinalume®. The paint/coating will reflect differently when the panels are reversed and could look like a different color.

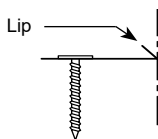

# Panel Preparation



**ROLLED STEEL PRODUCTS**  
a Taylor Metal Company

## Top of Panel - Upend

To up-end panels, snip the pan 7/8" beside the female rib, and 7/8" at 1/4" from the inside of the male leg. The up-end tool makes an accurate marking template. After snipping 7/8" cuts, place up-end tool into pan and bend up to just over 90 degrees. The up-end acts as a baffle. The 1/4" gap at the screw flange allows for clearance to snap in the next panel. You will need to fill the gap at each side of the upended panel with flex seal. (Figure 1)

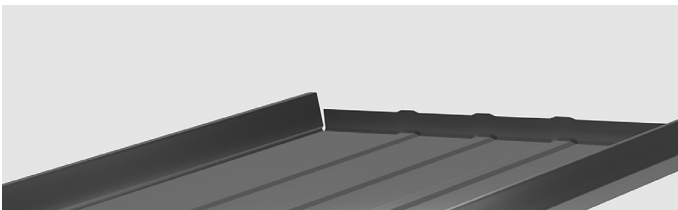
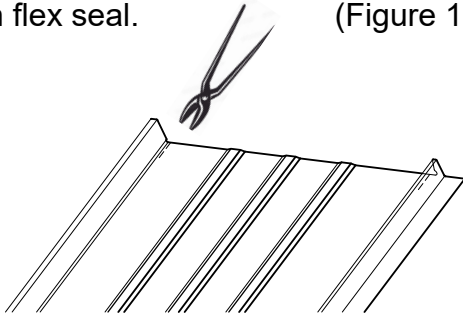

Figure 1

## Bottom of Panel

Snip off the corner of the fastening flange approximately 45° for appearance. (Figure 2)

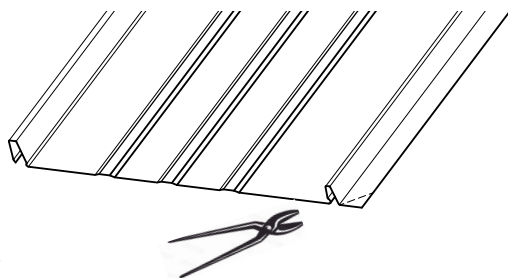
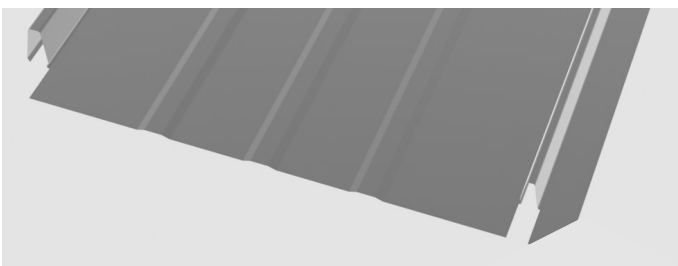

Figure 2



## Low Pitch Applications

### Alternate 1

On pitches of less than 3/12, place up-end tool into pan, bend down and under to form an open hem under the pan. This step brings the pan edge below the eave flashing edge which stops any potential wicking or siphoning. (Figure 3) If using this method, allow for an additional 1/2" of panel length.

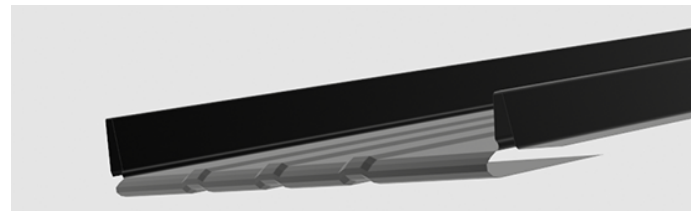
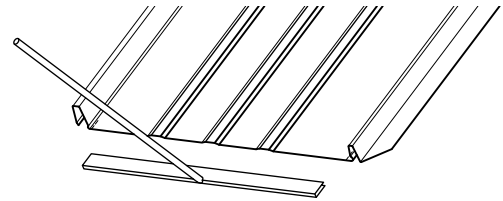

Figure 3

### Alternate #2

On pitches of less than 3/12, use a 1/2" bending tool or other bending tool and make a 30° bend (down) to form a drip edge on the pan of the panel. (Figure 4)

On projects less than 3/12, contact a RSP sales representative with project specifics.

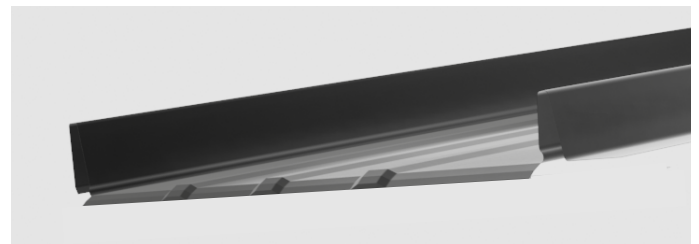
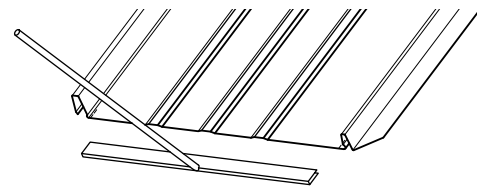

Figure 4

**Note: RSP minimum slope recommendation is 3/12 pitch.**





## Prior to Panel Installation:

**Before you can install the panels you need to install Underlayment (i.e. Felt Paper), Flyscreen, Eave Flashing, Valley Flashing, Prow Gable Flashing, and other flashings as conditions apply.**

Consider the following before ordering and/or installing roofing panels or flashing.

The roof area will rarely come out to the even foot. If working on a gable roof and the incremental distance from gable end to gable end is 4" or less (i.e. 48' 4") consider using the compensating gable flashing. This flashing is used to compensate up to 2" on either one or both ends of the roof. The beginning panel can be started 2" in for the edge and end 2" for the opposite edge.

Although to maintain a visually consistent appearance on each gable end, RSP recommends using compensation gable on both ends, rather than standard gable on one end and compensating gable on the other. Using the compensation gable flashing will keep you from having to cut a narrow panel for one end of the roof and will produce a more appealing visual appearance.

Compensating gable flashing is also useful if the roof is out of square and can take up 2" of top to bottom differential.

In the rare case that you should experience difficulty installing a panel due to a factory defect **stop immediately** and contact RSP (a Taylor Metal Products Company). Roof longevity may be compromised and warranty voided by knowingly installing faulty panels. RSP will not be responsible for panels installed with defects. RSP reserves the right to correct the issue before providing replacement panels.

## First Panel Installation:

You may install the panels working from left to right or right to left. It is a matter of choice and convenience. Determine which direction the panels are to be installed before preparing the panel.

Align the upper (female) leg of the panels along the alignment line you made along the gable edge. Allow the panel to overhang at the eave edge 1" to 1-1/4". Apply double row of non-skinning butyl or single row of double bead butyl tape along the eave flashing, position the panel and fasten the panel into place using the waferhead screws. Be certain screw heads are level and flush to the screw flange or they may dent or show through the next panel.

## Second and Successive Panels:

Apply the bead of caulking on the eave flashing (see Eave Section, page 15) and place panels flush along the eave edge maintaining the overhang established on the first panel.

Position the female leg of the next panel over the male leg of the panel previously installed and lock the panels into place using light hand pressure, foot pressure or tap in place with a rubber mallet. Lock the panels from the bottom up. When the rib is locked into place and in the proper position, fasten the panel into place with waferhead screws.

Repeat for successive panels.

# Low Pitch Eave



**ROLLED STEEL PRODUCTS**  
a Taylor Metal Company

## LOW PITCH EAVE DETAIL

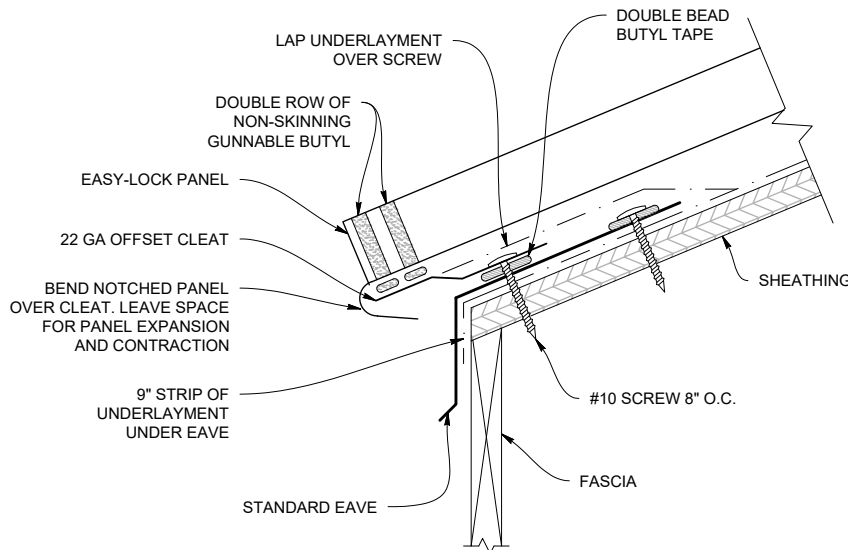

## LOW PITCH EAVE FLASHING (ELELP)

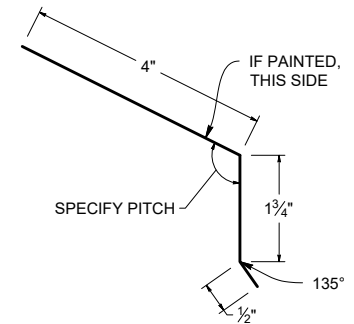

## OFFSET CLEAT (ELOC)

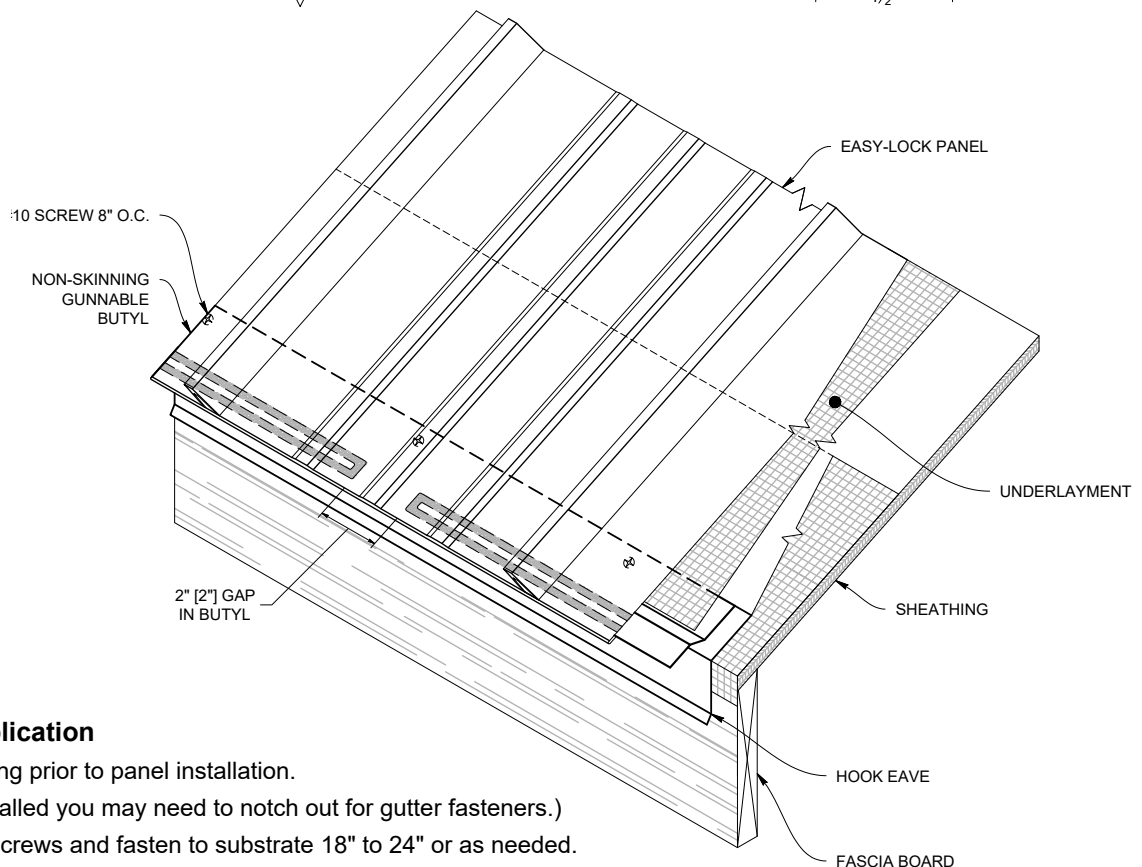
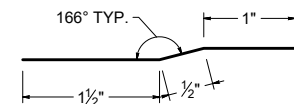

### Eave Flashing Application

- Install eave flashing prior to panel installation.  
(If gutters are installed you may need to notch out for gutter fasteners.)
- Use Waferhead Screws and fasten to substrate 18" to 24" or as needed.
- Allow 1" to 2" lap and apply sealant to overlap.
- Apply 2-1/4" beads of sealant along top of leg of eave flashing, 1" +/- from outside edge.  
(You may also use butyl mastic.)
- Install fascia leg into gutter.
- Insulate between dissimilar metals.

**Note: Customize flashing for more or less coverage.**

**Note: If you experience panel crowning, back bend panels at bottom of panel or turn down edge.**



## HOOK EAVE DETAIL

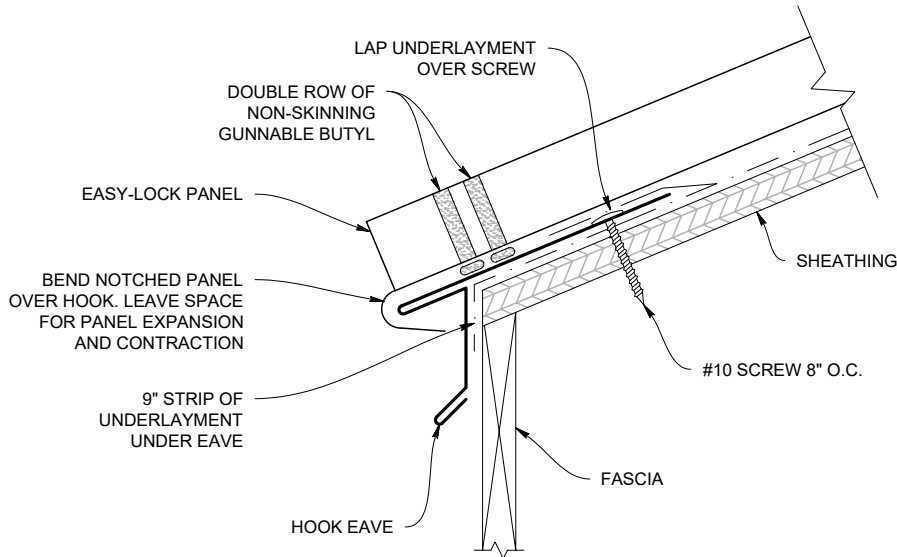

## HOOK EAVE FLASHING (ELEH)

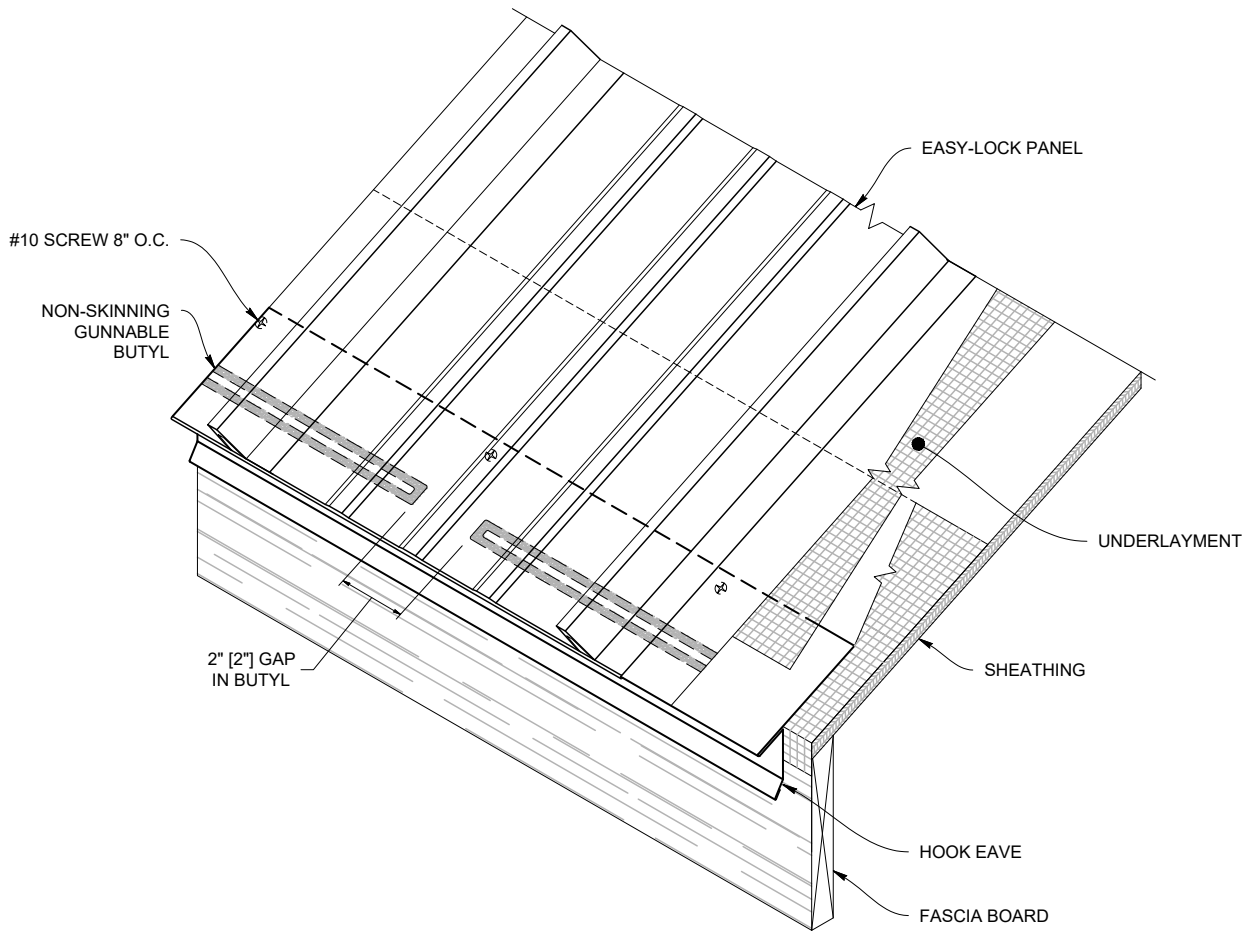
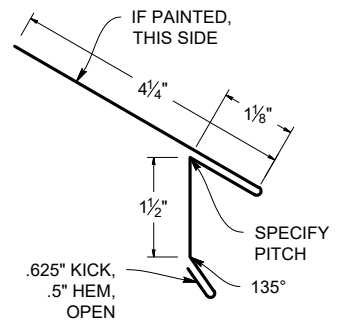

# Hook Eave with Gutter



**ROLLED STEEL PRODUCTS**  
a Taylor Metal Company

## GUTTER HOOK EAVE DETAIL

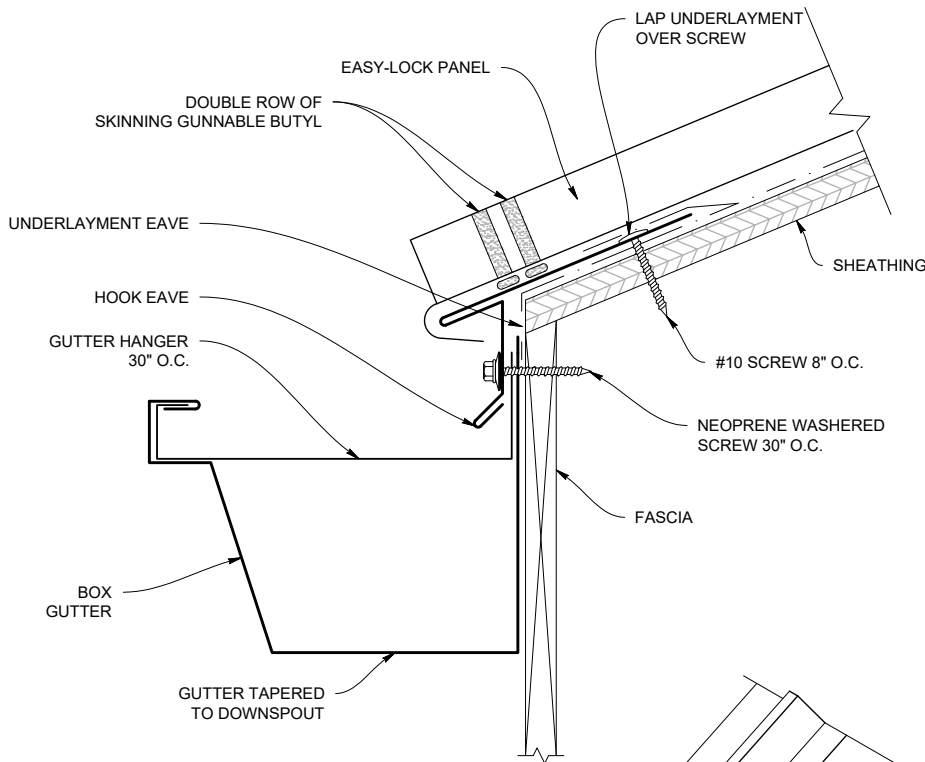

## BOX GUTTER FLASHING

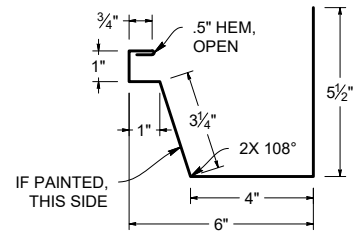

## HOOK EAVE (ELEH)

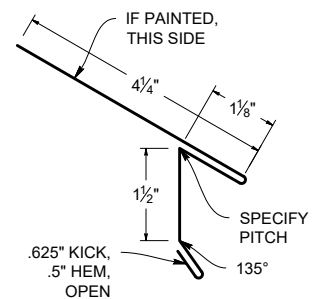

## BOX GUTTER HANGER (AGH6)

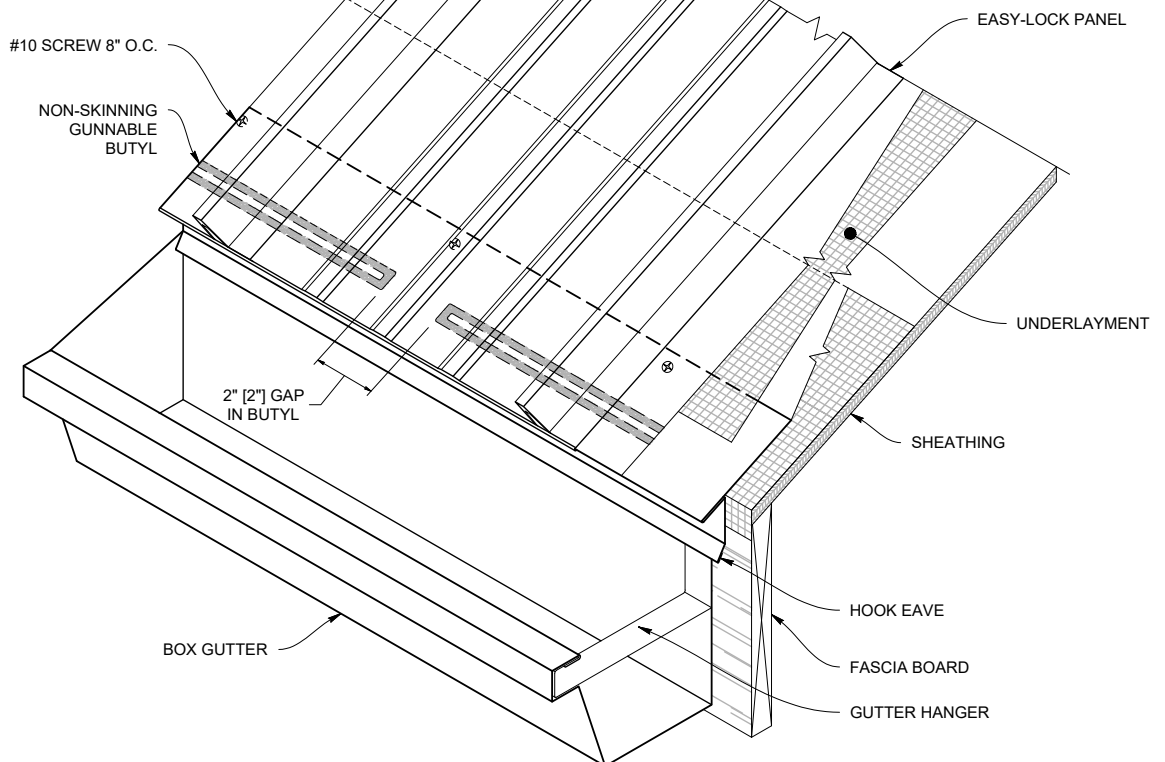
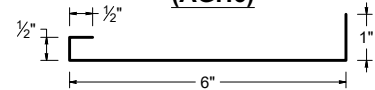



## HIP / RIDGE DETAIL

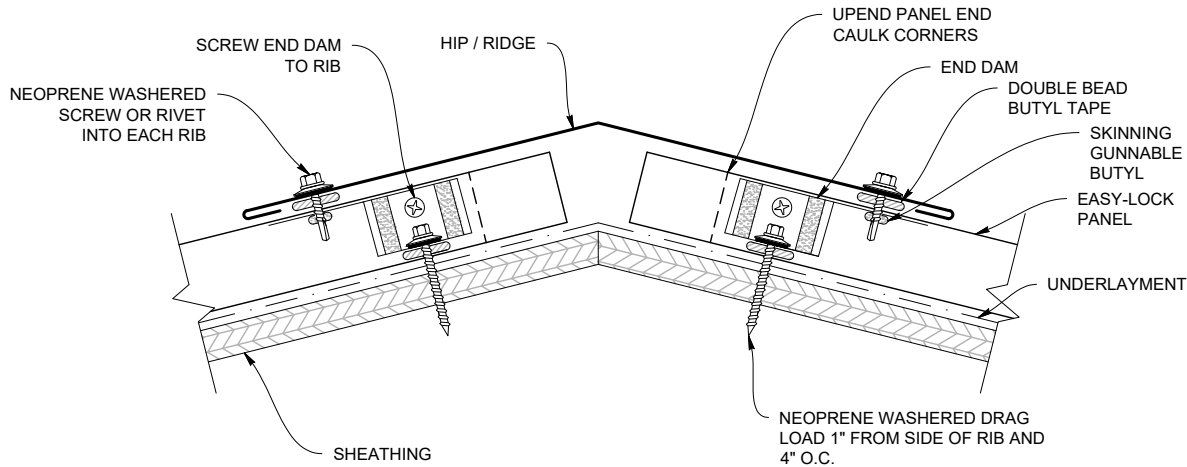

### Hip / Ridge Application

- Cut standing seam panel to match angle of hip/ridge.
- Install panels and upend; caulk the corners.
- Notch hip/ridge cap (as required) for ribs on panel(s). Notch with snips to match rib alignment.
- Allow hip/ridge cap to overhang the bottom corner at least 1-1/2".
- Box in the lower end to match angle of corner.
- Overlap hip/ridge cap, top to bottom, 2" to 3" and caulk each lap.
- Attach hip/ridge cap to each rib of panels with woodfast screw, pop rivet, or stitch screw.

**Note: If ribs are over 24" apart on panel angles, use "Z" Strip for secure fastening.**

### HIP / RIDGE FLASHING (ELHR)

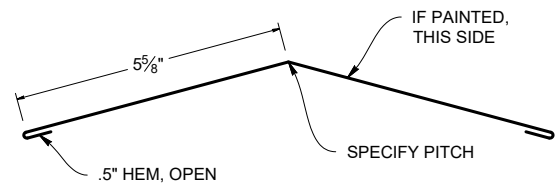

### HIP / RIDGE LAP

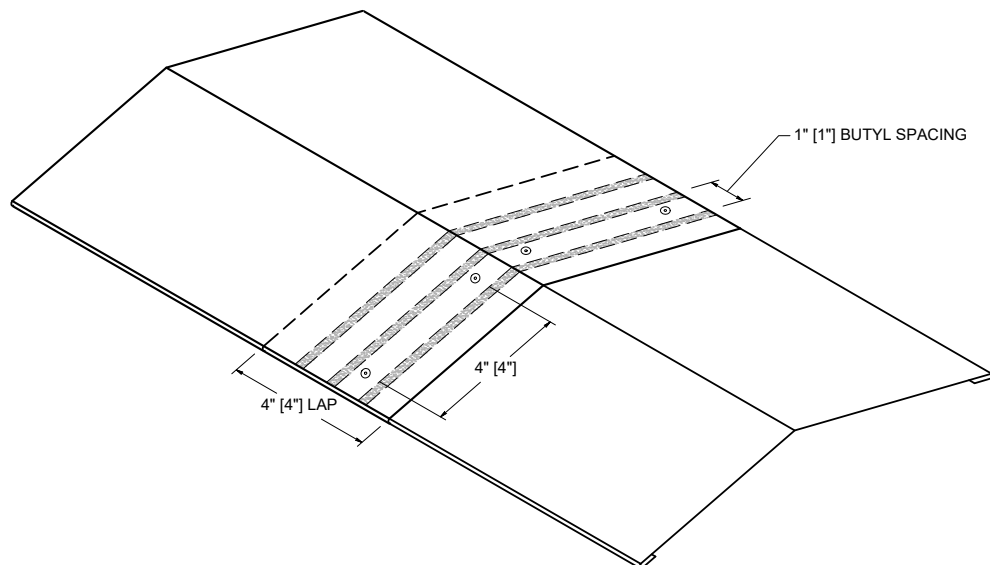

# Vented Ridge



**ROLLED STEEL PRODUCTS**  
a Taylor Metal Company

## RIDGE W/ VENTED CLOSURE DETAIL

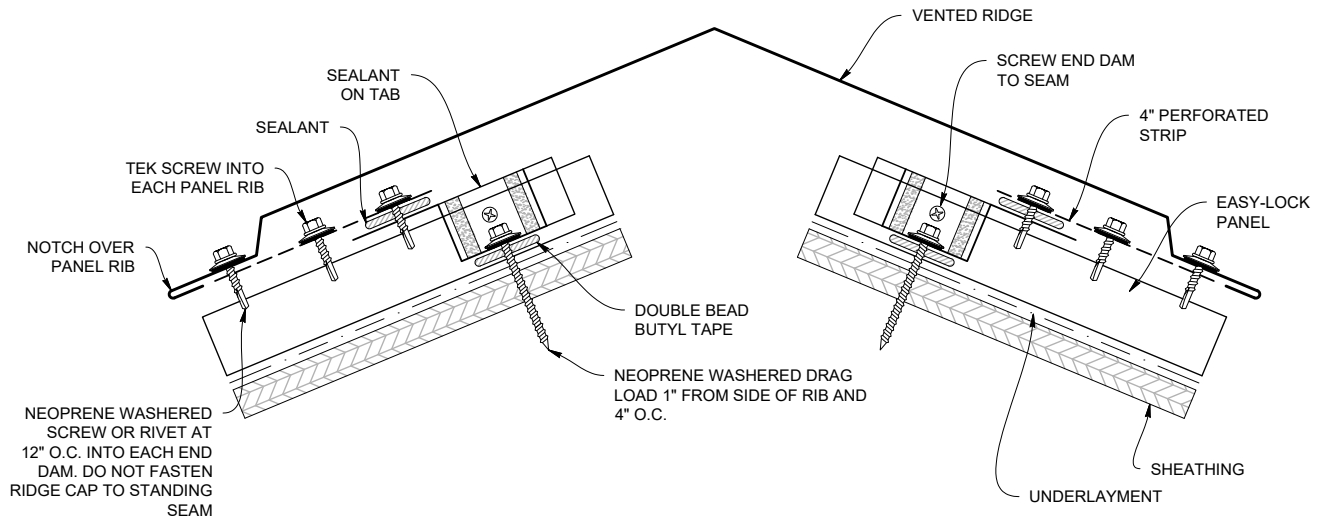

## EASY-LOCK END DAM

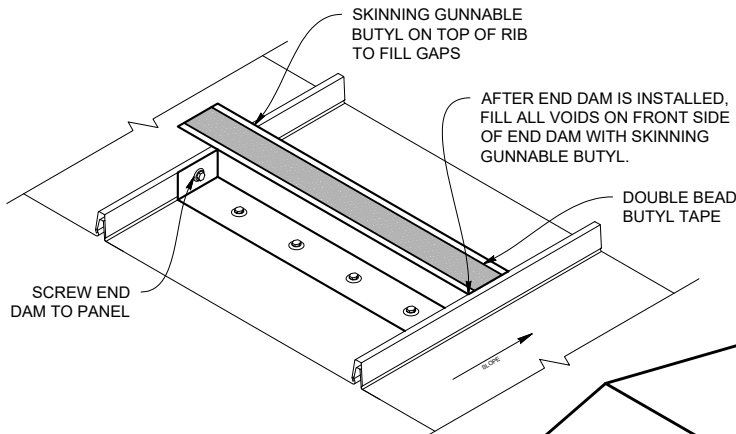

## R17 RIDGE FLASHING (ELR17)

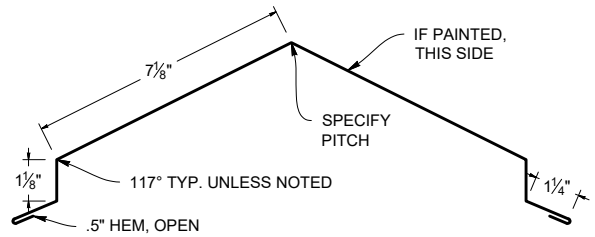

## RIDGE LAP

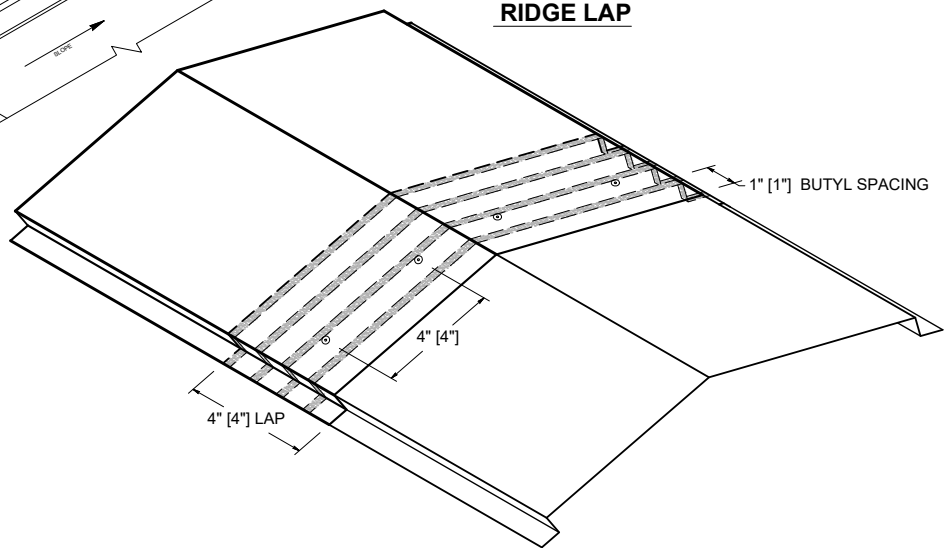



**VALLEY DETAIL**  
(3:12 or Greater Pitch)

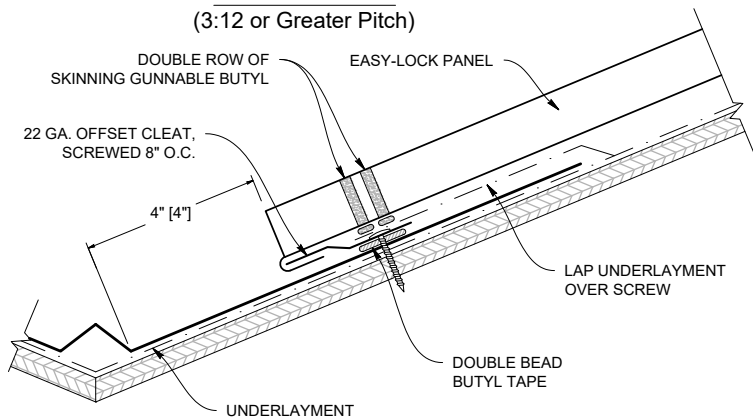

**OFFSET CLEAT (ELOC)**

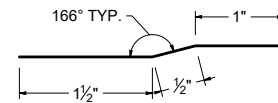

**VALLEY FLASHING (ELVF24)**

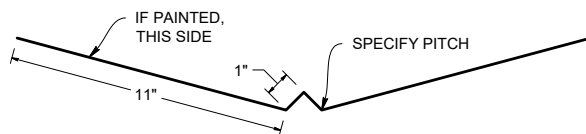

**VALLEY LAP**  
(3:12 or Greater Pitch)

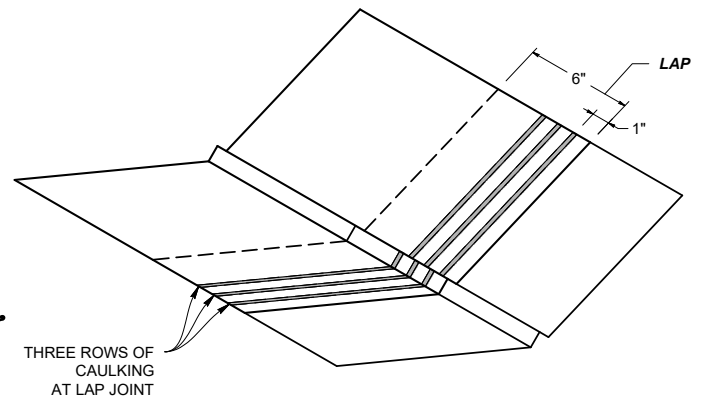

**WIDE VALLEY FLASHING (ELVFW)**

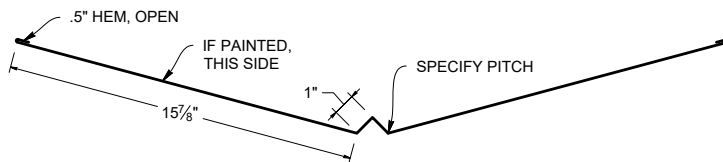

**Valley Flashing Application**

- Install valley flashing by fastening through the pan as near to the outside edge (near the hem) as possible every 18" to 24" on each side. Cover fastener heads with sealant/caulking.
- Cut hems 6" back on each side of the next valley flashing. Apply three 1/4" beads of caulking between the valley pans.
- Form valley flashing over the ridge as necessary.
- Trim panels for angle of valley 2" from the valley center point.
- **Note: Be sure to remove any burrs from the cut edge of panels and use a damp cloth to wipe any filings from the panel.**
- If the panels crown (pan of panel raising up) backbend panel or use the 1/2" upending tool and either bend the panel end down 30 degrees or turn the 1/2" under, forming a hemmed edge.
- Apply butyl mastic tape, or a 1/4" bead of sealant/caulking, up 1" from panel edge.
- **If using a wide valley, the panels will be set farther from the center of the valley pan, place butyl tape so it is 1" from end of panel.**
- Apply a bead of sealant/caulking on top of the hems of the valley flashing.
- Install panels being sure to fasten panels through the fastening flange into substrate, as close as possible to hemmed edge of valley flashing. Do not penetrate the valley flashing.
- **Heavy snow conditions require a wider valley pan. Leave more space between the end of the valley panels and the valley center line.**
- Consider using wide valley flashings for low pitch roofs.

# Valley - Low Pitch

Slope Less than 3:12



**ROLLED STEEL PRODUCTS**  
a Taylor Metal Company

## VALLEY FLASHING DETAIL (Less Than 3:12 Pitch - Not Recommended)

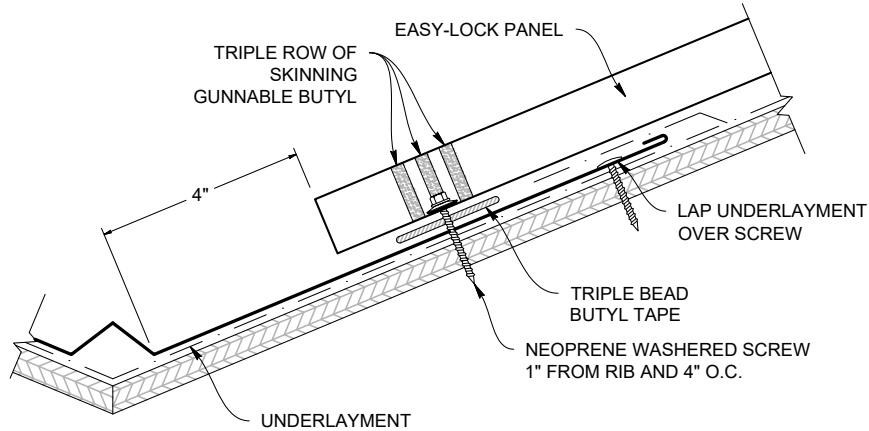

## VALLEY FLASHING 24" (ELVF24)

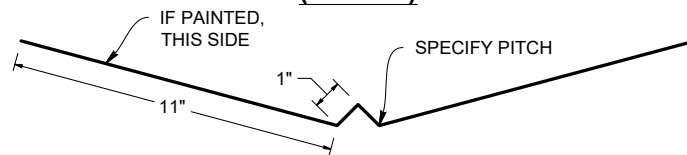

## WIDE VALLEY FLASHING (ELVFW)

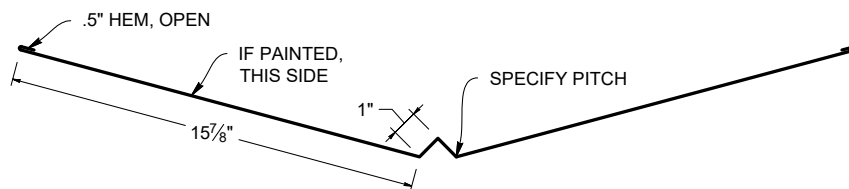

## VALLEY LAP (Less Than 3:12 Pitch - Not Recommended)

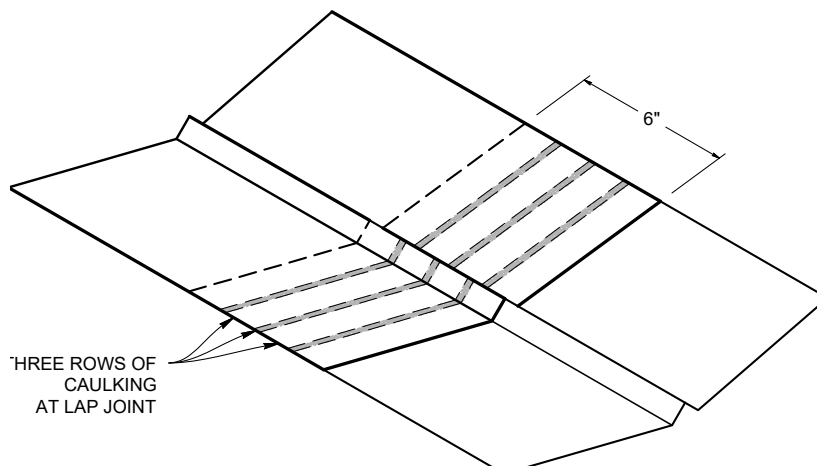





### BOX GABLE DETAIL

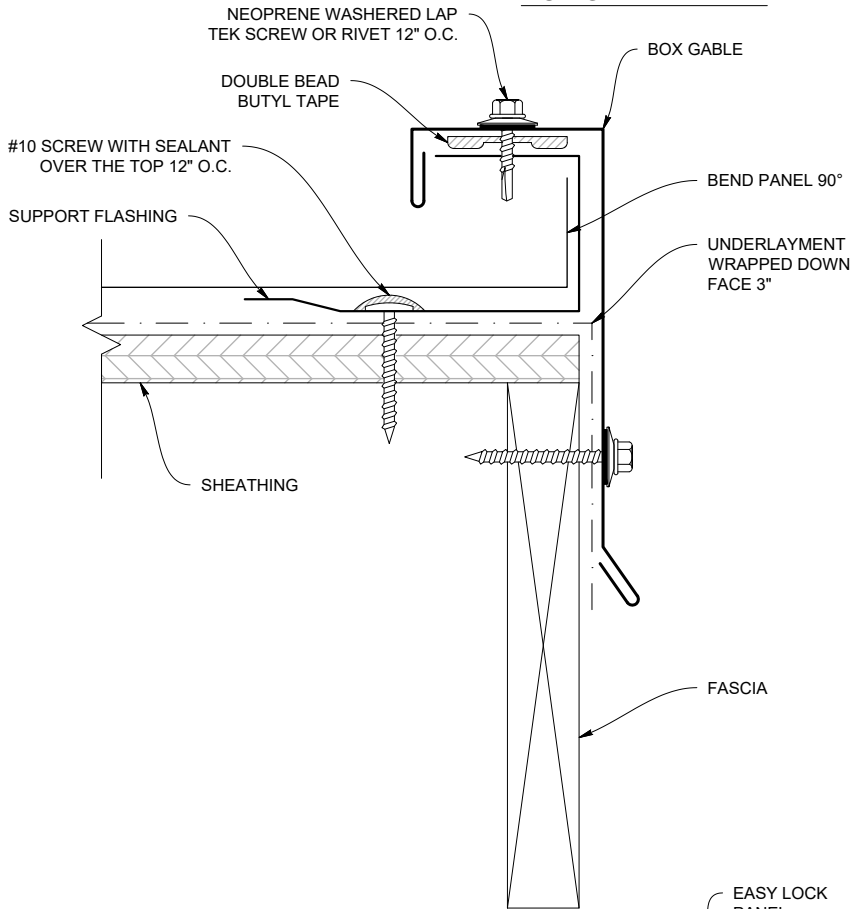

### BOX GABLE FLASHING (ELGB)

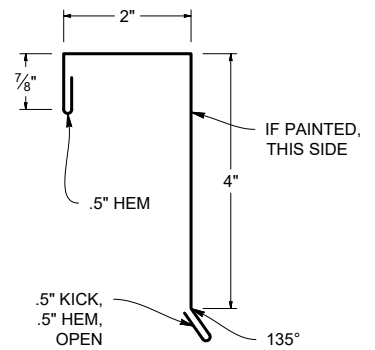

### SUPPORT FLASHING (ELSF)

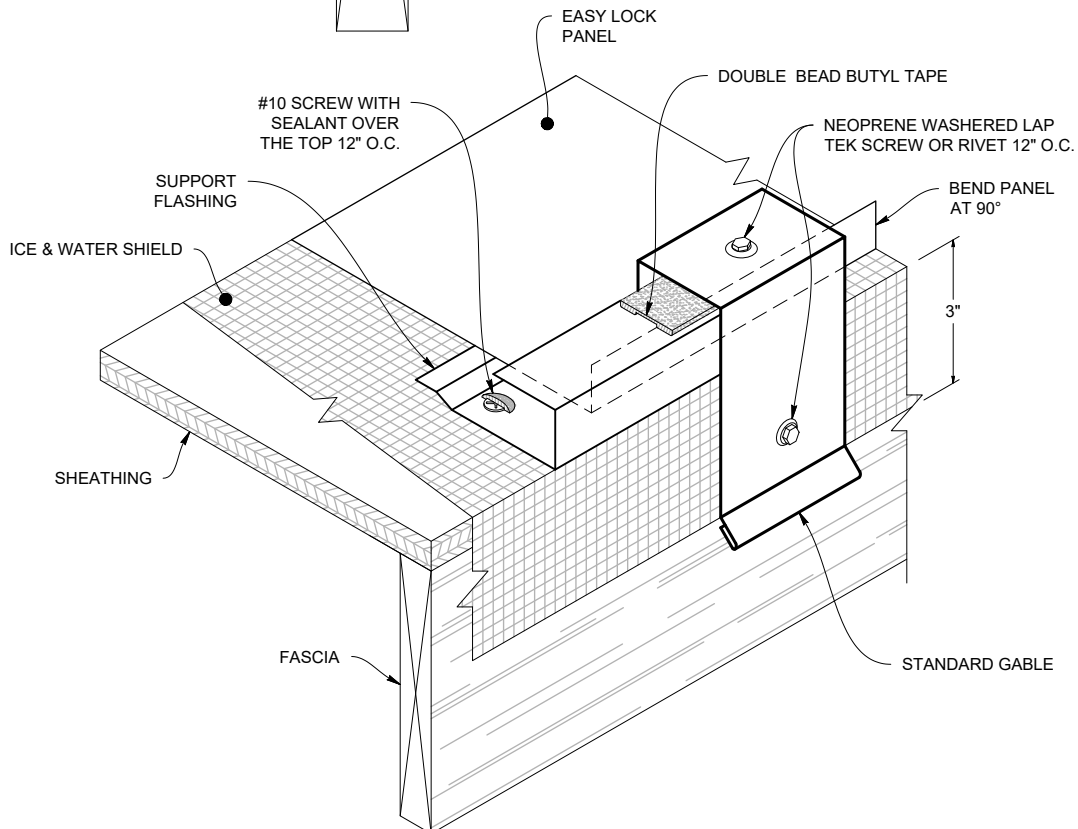
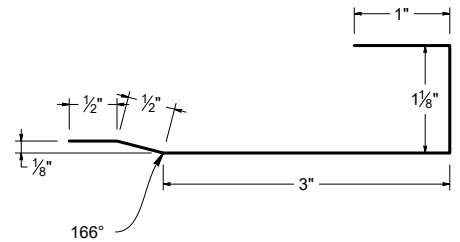

## PROW DETAIL

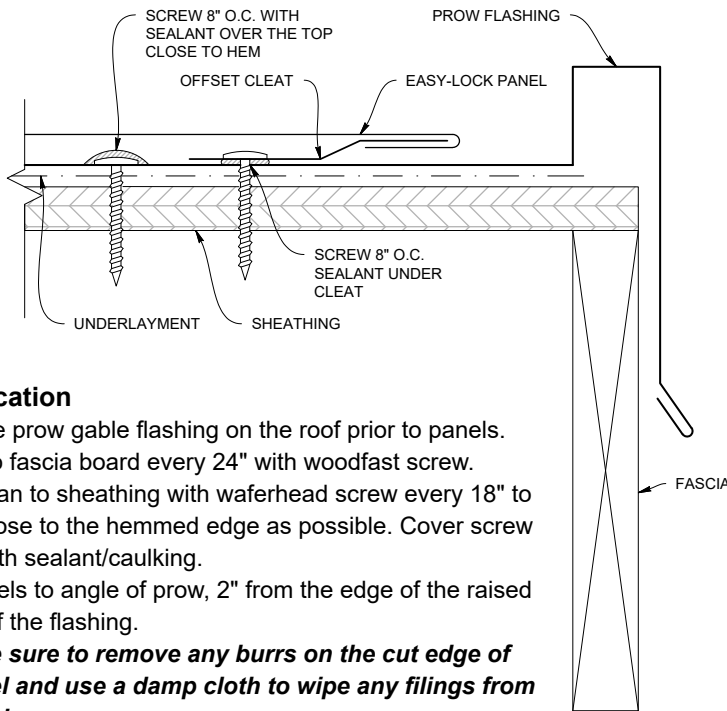

## PROW FLASHING (ELPF)

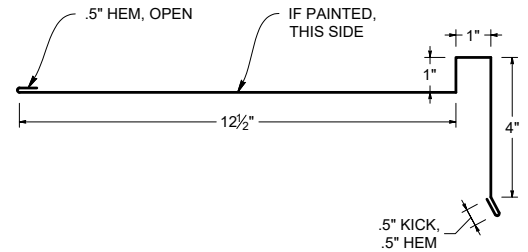

## OFFSET CLEAT (ELOC)

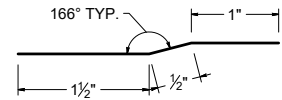

## Prow Application

- Install the prowl gable flashing on the roof prior to panels.
- Fasten to fascia board every 24" with woodfast screw.
- Fasten pan to sheathing with waferhead screw every 18" to 24" as close to the hemmed edge as possible. Cover screw heads with sealant/caulking.
- Trim panels to angle of prowl, 2" from the edge of the raised portion of the flashing.

**Note: Be sure to remove any burrs on the cut edge of the panel and use a damp cloth to wipe any filings from the panel.**

- Apply butyl tape or 1/4" bead of sealant/caulking 3" from the raised edge of the prowl flashing, (1" under end of panels). Apply a 1/4" bead of sealant/caulking to the top of the hem of the prowl flashing.
- Fasten the panels as close to the hemmed edge of the prowl flashing as possible.
- Due to the long cuts typical of the angle of the prowl, using the 1/2" upending tool, bend the cut edge down 30 degrees or turn the edge under forming a hem.

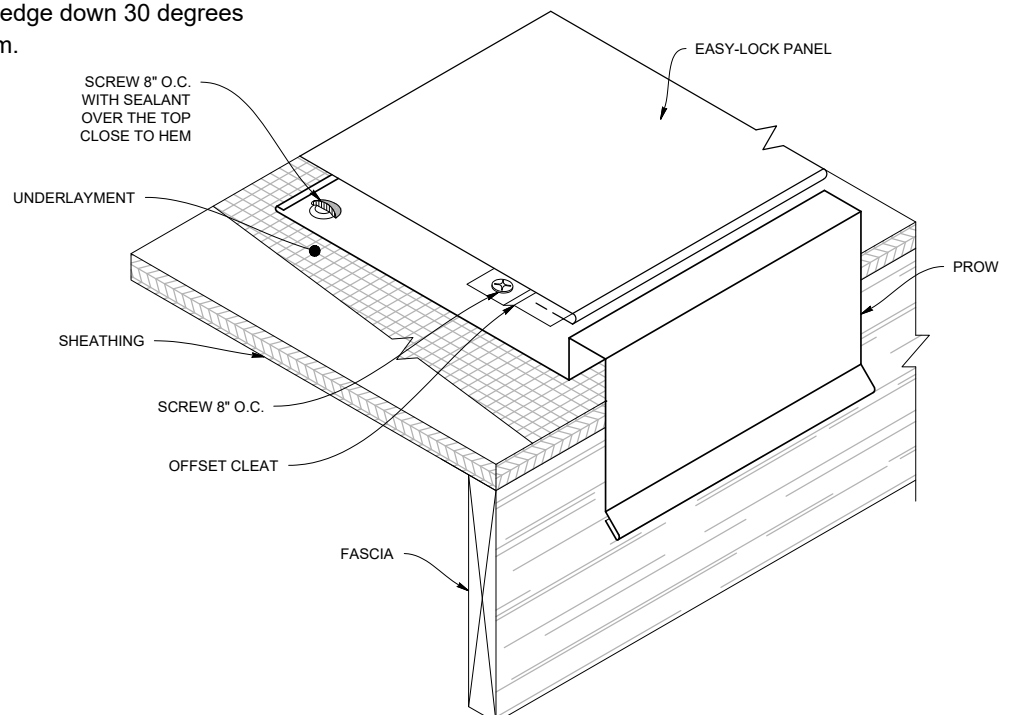



### SIDEWALL DETAIL

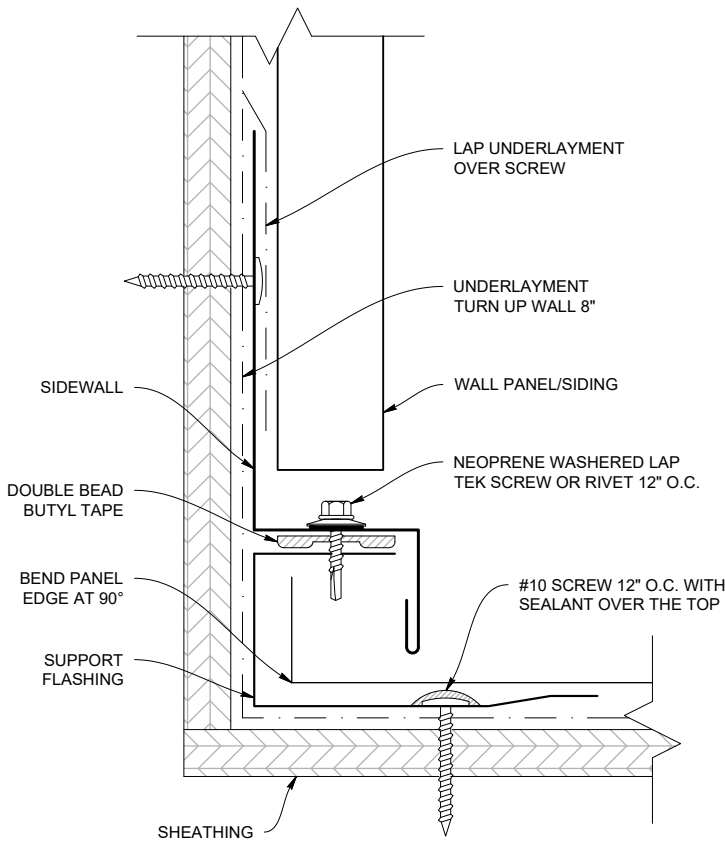

### SIDEWALL & COMPENSATING SIDEWALL (ELSW) (ELSWC)

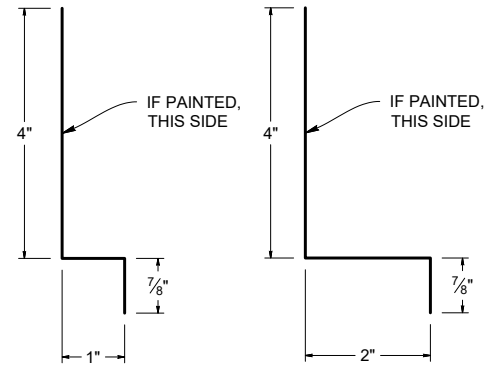

### SUPPORT FLASHING (ELSF)

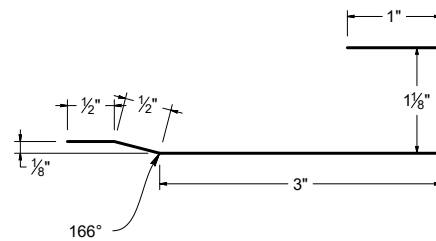

### Sidewall Application

- Sidewall flashing is used where wall runs parallel with slope.
- Install roofing panel first.
- Flash over rib if starting panels at wall or over upended edge of panel (pictured).
- Install flashing under siding (pictured). Attach to wall with waferhead screw for this option.

**OPTION:** Siding is cut 1/4" deep and lip is caulked into the cut to seal. Attach to wall with woodfast screw every 24".

**Note: Specify with lip if using this method of installation.**

- Overlap flashing end to end 2" to 3" and caulk at lap.

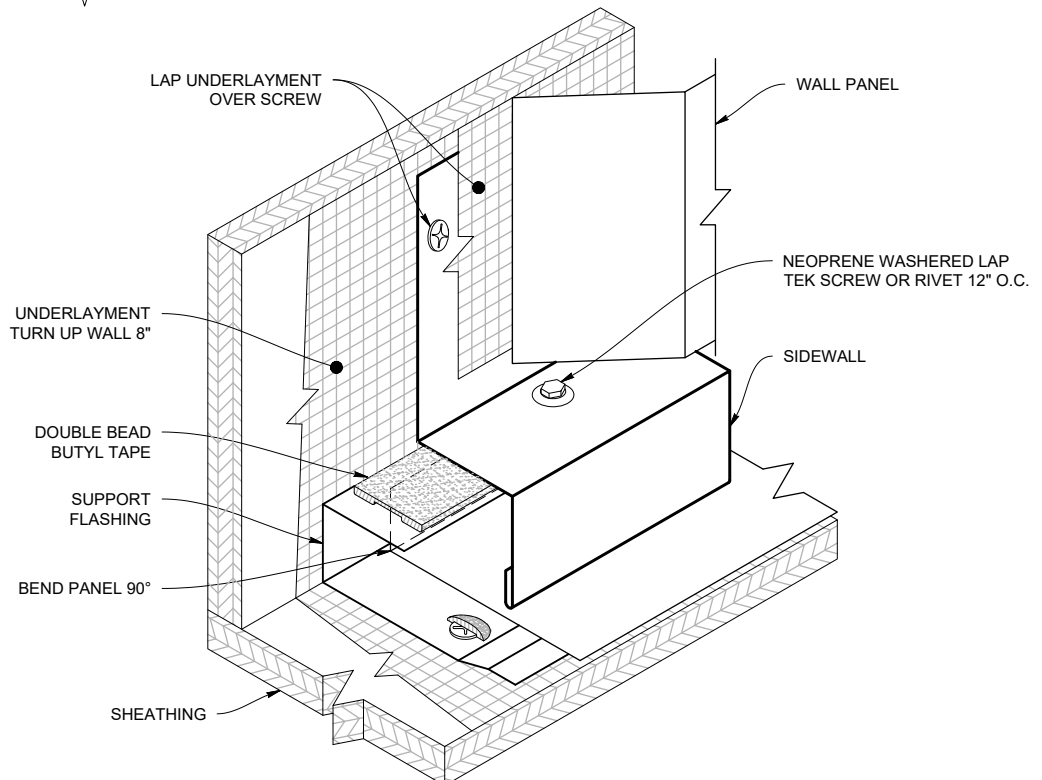

# Peak Flashing

(Ridge End Cap)



**ROLLED STEEL PRODUCTS**  
a Taylor Metal Company

## PEAK FLASHING DETAIL (Ridge End Cap)

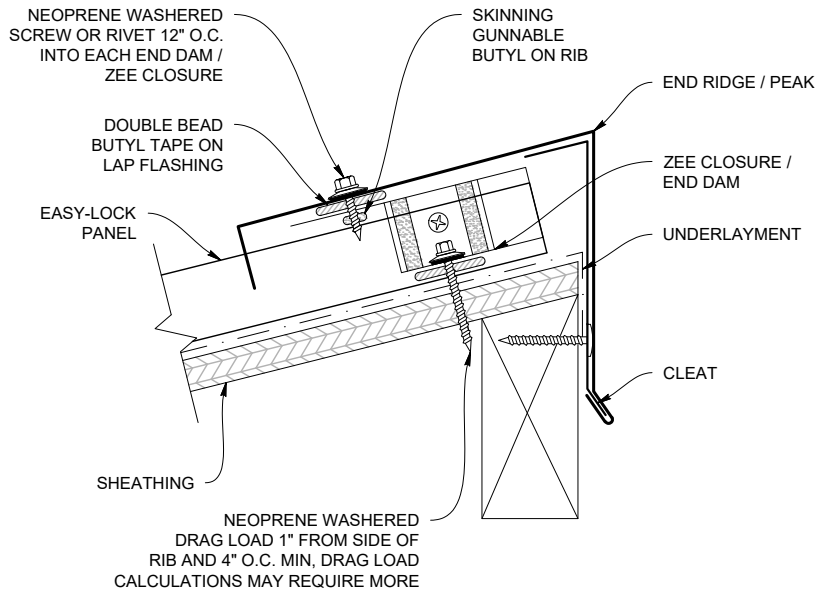

## FIELD NOTCHED PEAK FLASHING (ELREC)

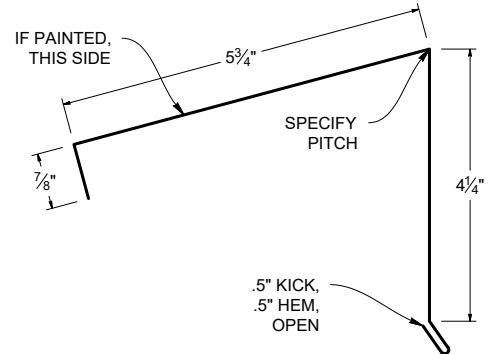

## PEAK CLEAT (ELRECC)

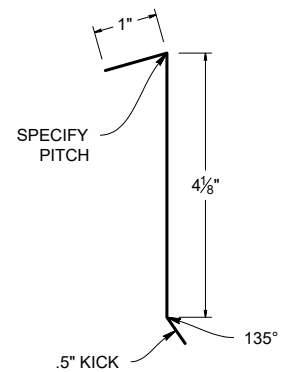

### Peak Flashing Application (R. E. C.)

- Notch 1" leg to fit over rib of panel.
- Fasten through peak flashing into ribs of panel every 24" with woodfast screw or rivit.
- Fasten through 4-3/4" leg of peak flashing into fascia board every 24" with woodfast screw.
- Overlap flashing end to end 2" to 3". Place 1/4" bead of caulk under lap.
- Fasten peak flashing at lap with rivet or woodfast screw.

## PEAK LAP

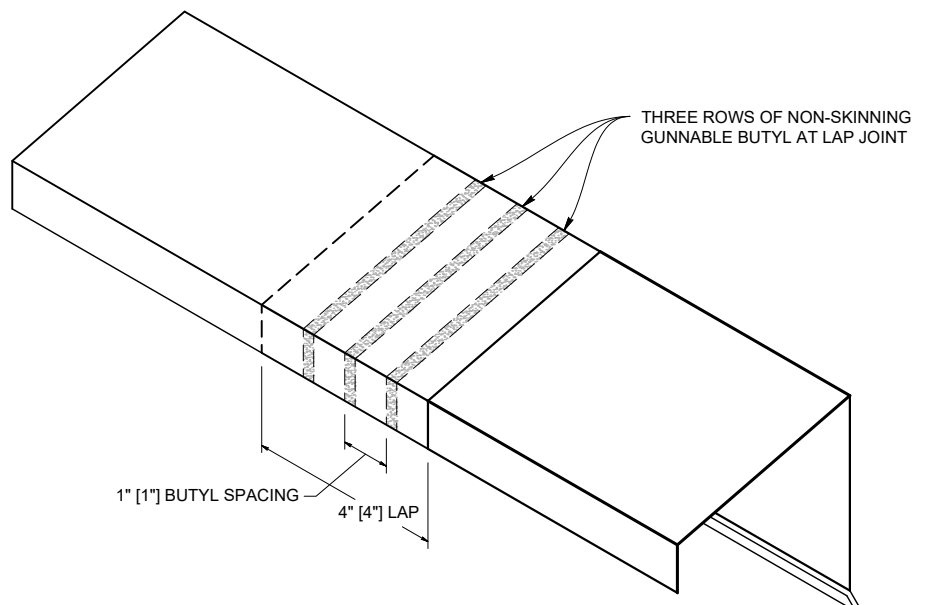

## HEMMED PEAK FLASHING (ELRECH)

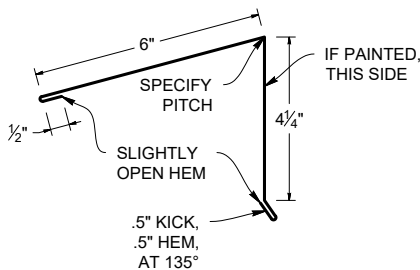



## PITCH CHANGE DETAIL

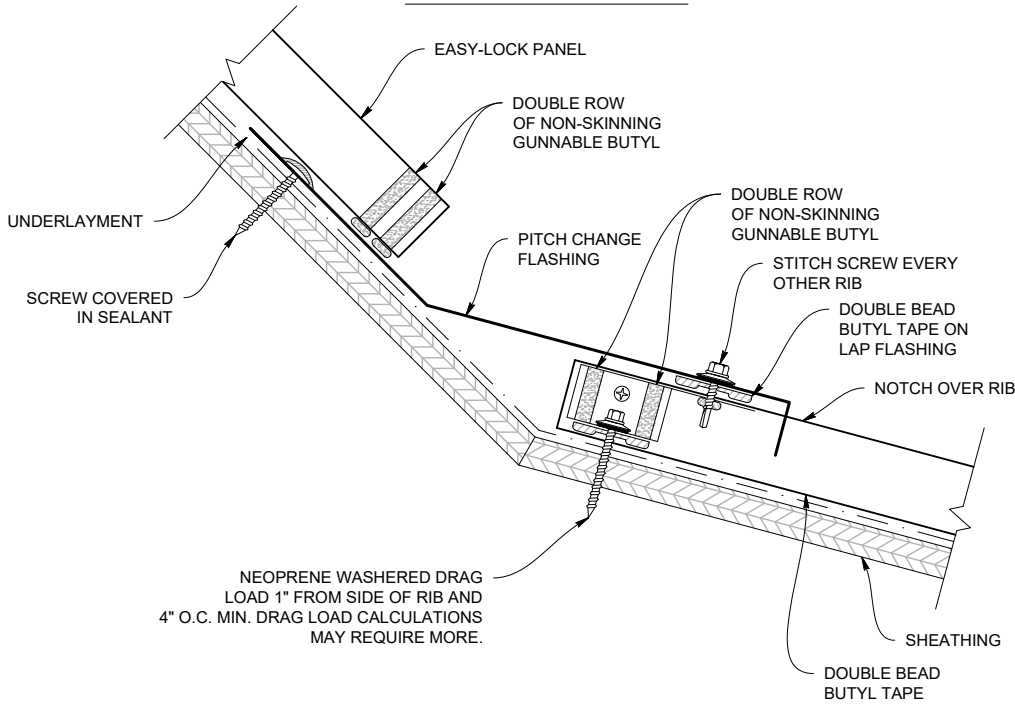

## INSIDE PITCH CHANGE (ELPCIN)

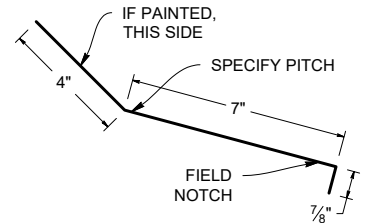

### Pitch Change Inside Application

- Install lower panels and all flashings associated with the lower roof. Upend panels, apply sealant/caulking to corners of up-ended pan.
- Notch 1" leg of flashing to fit over rib of panels.
- Attach upper leg of flashing to sheathing with a waferhead screw on the upper leg every 18" to 24" or as needed. Place sealant/caulking on screw head.
- Allow 3" overlap on flashing, apply three 1/4" beads of sealant/caulking under lap.
- Attach lower leg of flashing to every other rib, with a woodfast screw, rivet or stitch screw.
- Place a 1/4" bead of sealant/caulking on the upper leg of the flashing 1-1/2" from the break. Install the panels 1/2" from the break.

**Note: Custom flashings may be required when pitches are close, e.g. 3:12 to 1:12.**

## PITCH CHANGE LAP

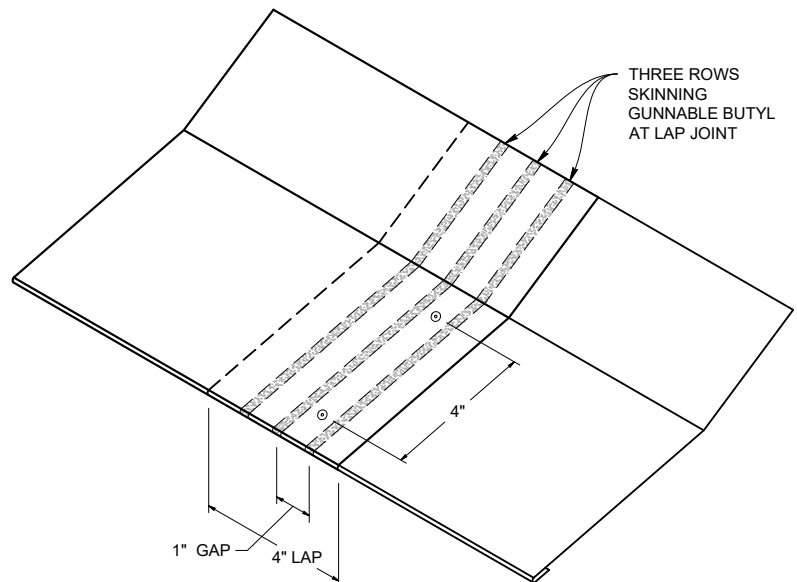

# Hemmed Endwall



**ROLLED STEEL PRODUCTS**  
a Taylor Metal Company

## HEMMED ENDWALL DETAIL

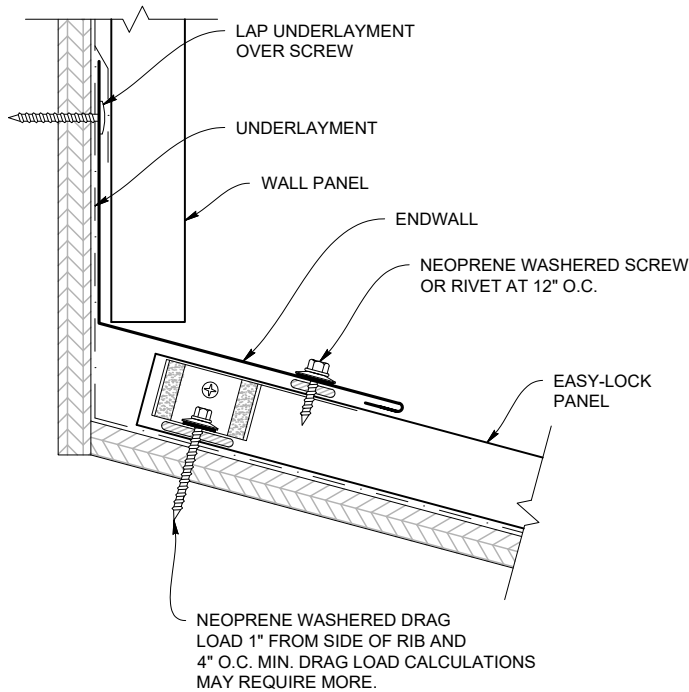

## HEMMED ENDWALL FLASHING (ELEWH)

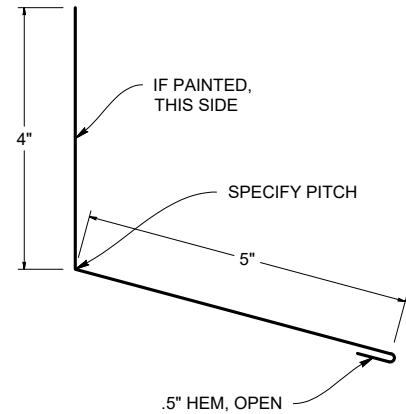

### Hemmed Endwall Application

- Endwall flashing is used where the roof slopes away from a wall (i.e., clerestory or shed roof.)
- Up-end top of panel and apply sealants/caulking to the corner of the up-ended pans before installing flashing.
- Notch 1" leg of endwall to fit over ribs of panels.
- Upper leg (2-1/2") is placed under siding.
- **OPTION:** Siding is cut 1/4" deep and the lip is caulked into the cut to seal.
- **Note: Specify with lip if using this method of installation.**
- Attach flashing to every other rib of panel with rivet, woodfast screw or stitch screw.
- Overlap flashing end to end 2" to 3". Place 1/4" bead of sealant/caulking under lap.

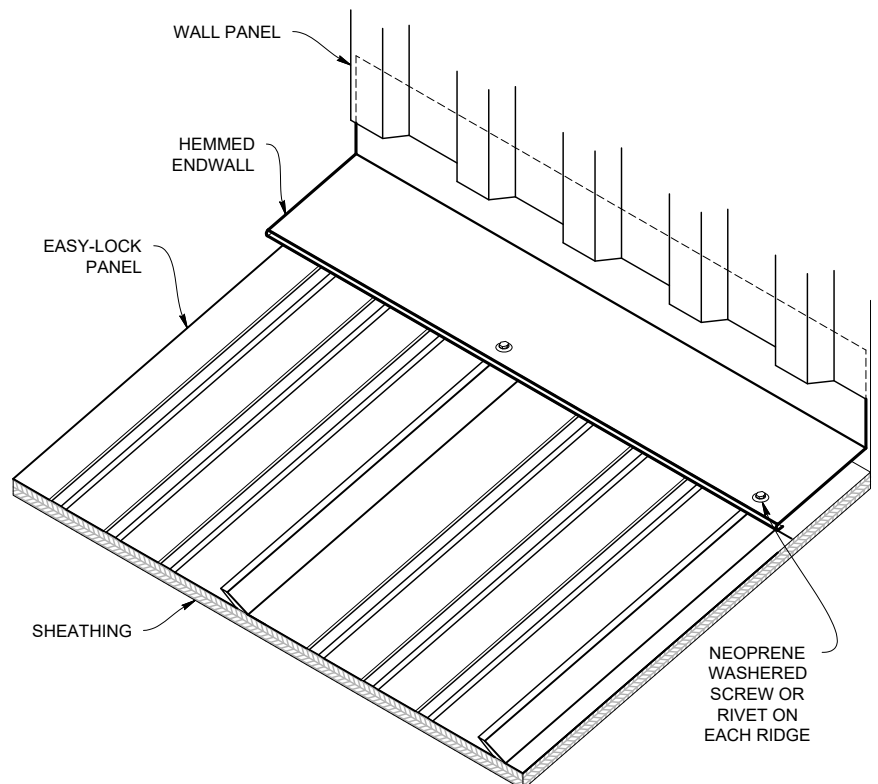



## VENTED ENDWALL DETAIL

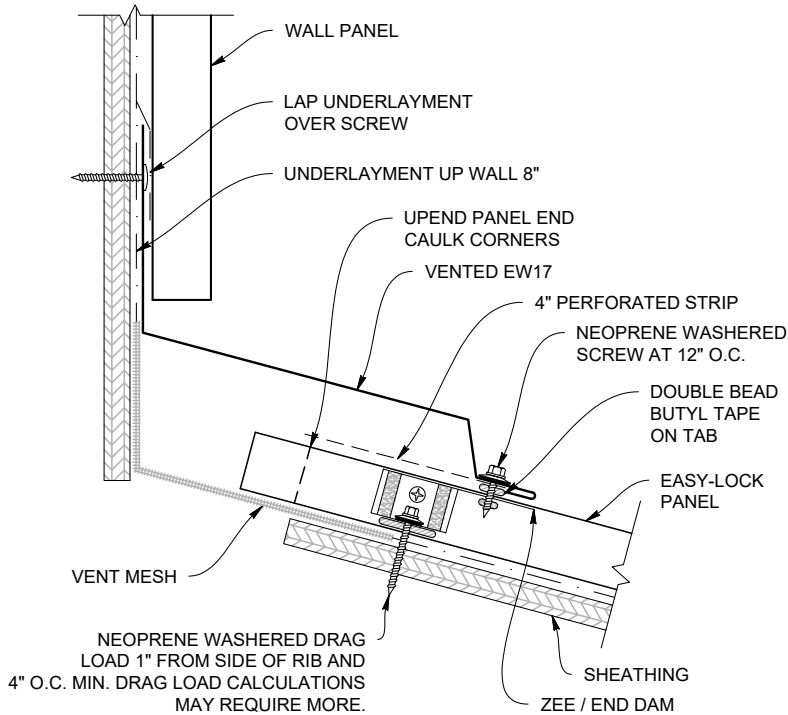

## EW17 ENDWALL FLASHING (ELEW17)

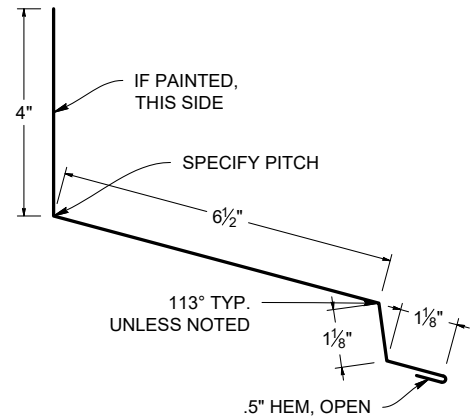

## ENDWALL LAP

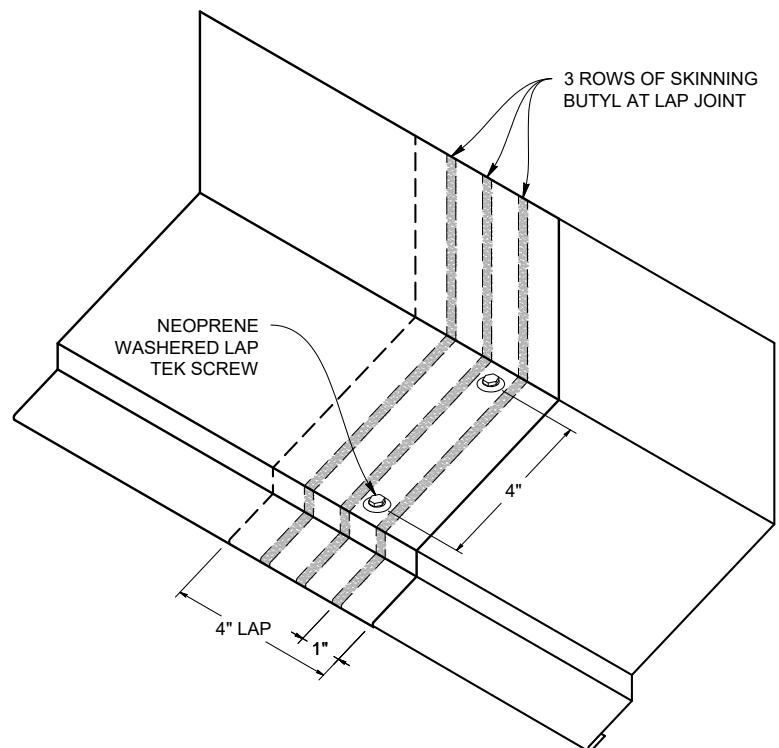

### Vented Endwall Application

- Vented endwall flashing is used to provide ventilation at the wall. Cut out or leave the sheathing back 2" from the wall and cover with vent mesh/flyscreen.
- Upend top of panel and caulk the corners before installing the flashing.
- Place the vented endwall flashing on top of the ribs of the panels. The upper leg (2-1/2") is placed under the siding.  
OPTION: Siding is cut 1/4" deep and the lip is caulked into the cut to seal.  
**Note: Specify with lip if using this method of installation.**
- Attach flashing to every other rib of panel with rivet, woodfast screw or stitch screw.
- Overlap flashing end to end 2" to 3". Place 1/4" bead of sealant/caulk under lap.

# End Dam



**ROLLED STEEL PRODUCTS**  
*a Taylor Metal Company*

## END DAM DETAIL

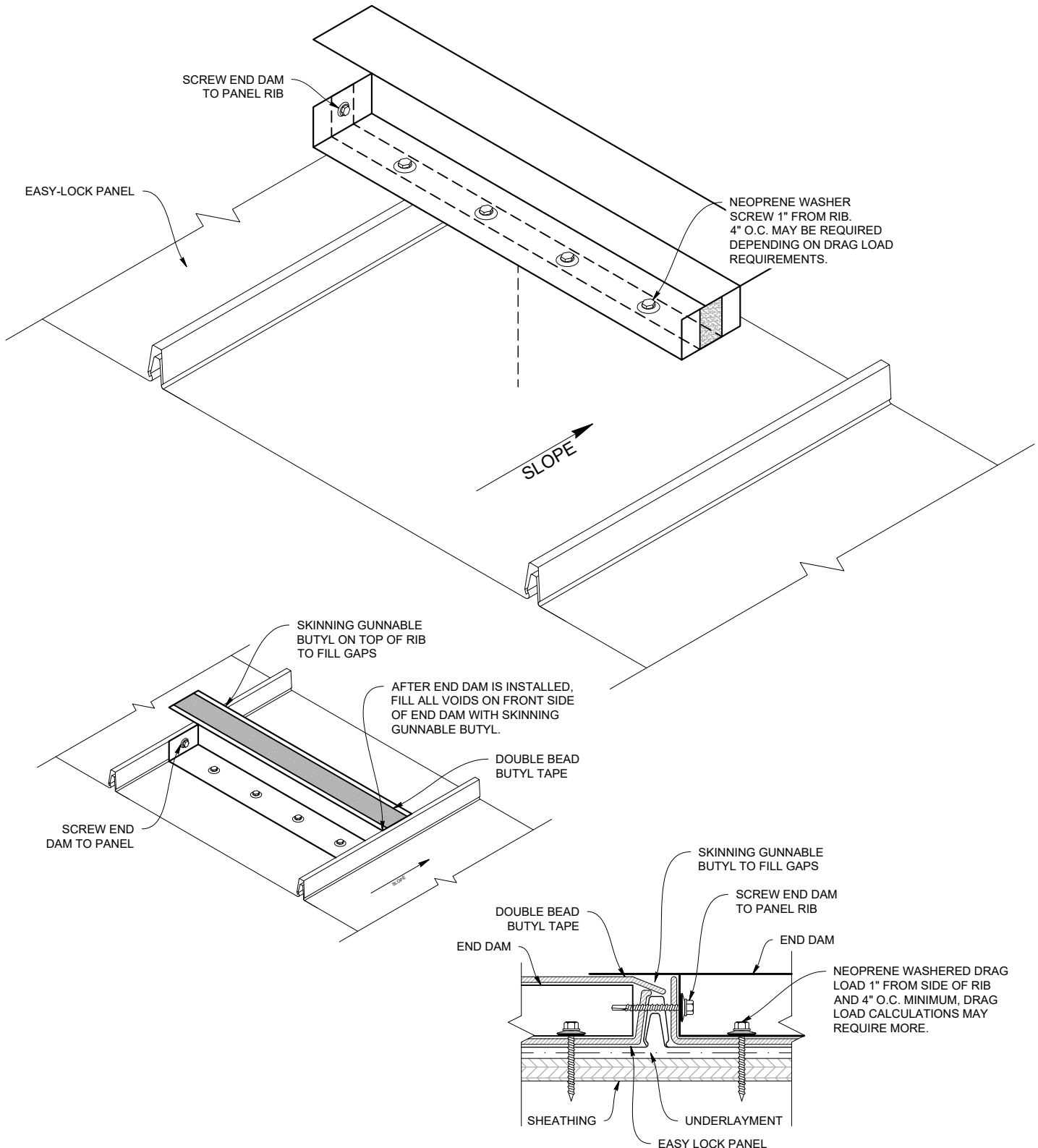





## Eave to Gable Transition

STEP 1

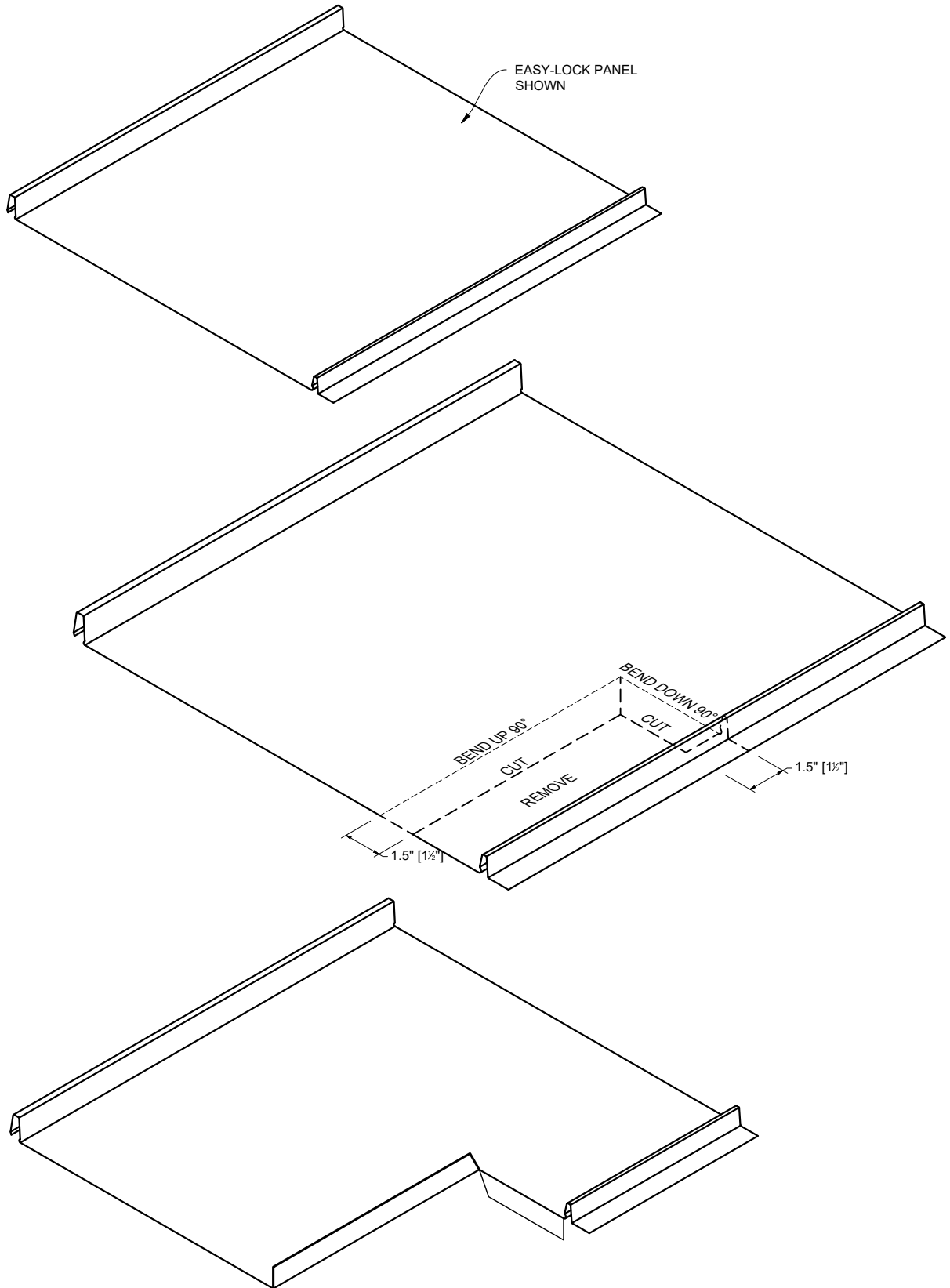

# Eave to Gable Transition



**ROLLED STEEL PRODUCTS**  
*a Taylor Metal Company*

## STEP 2

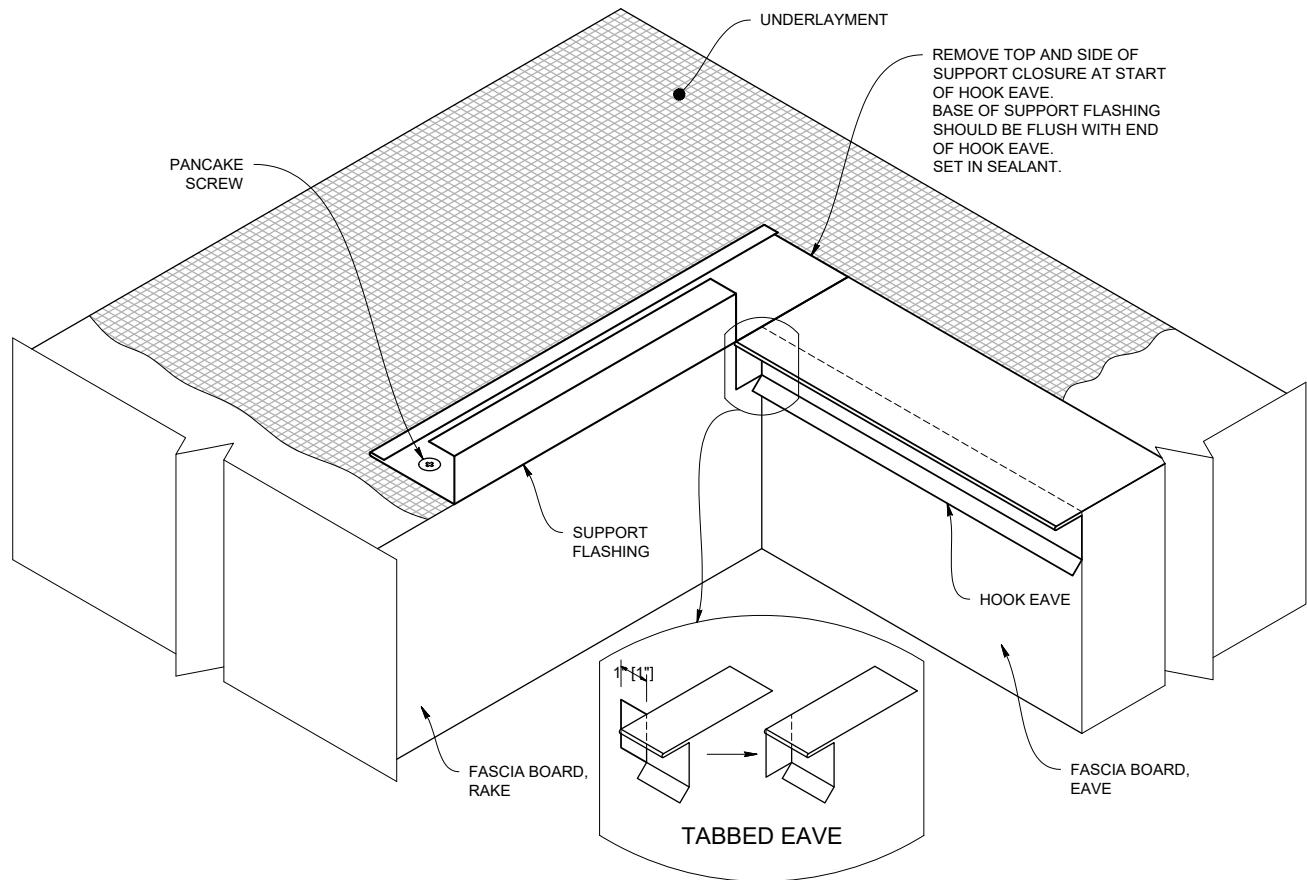



## STEP 3

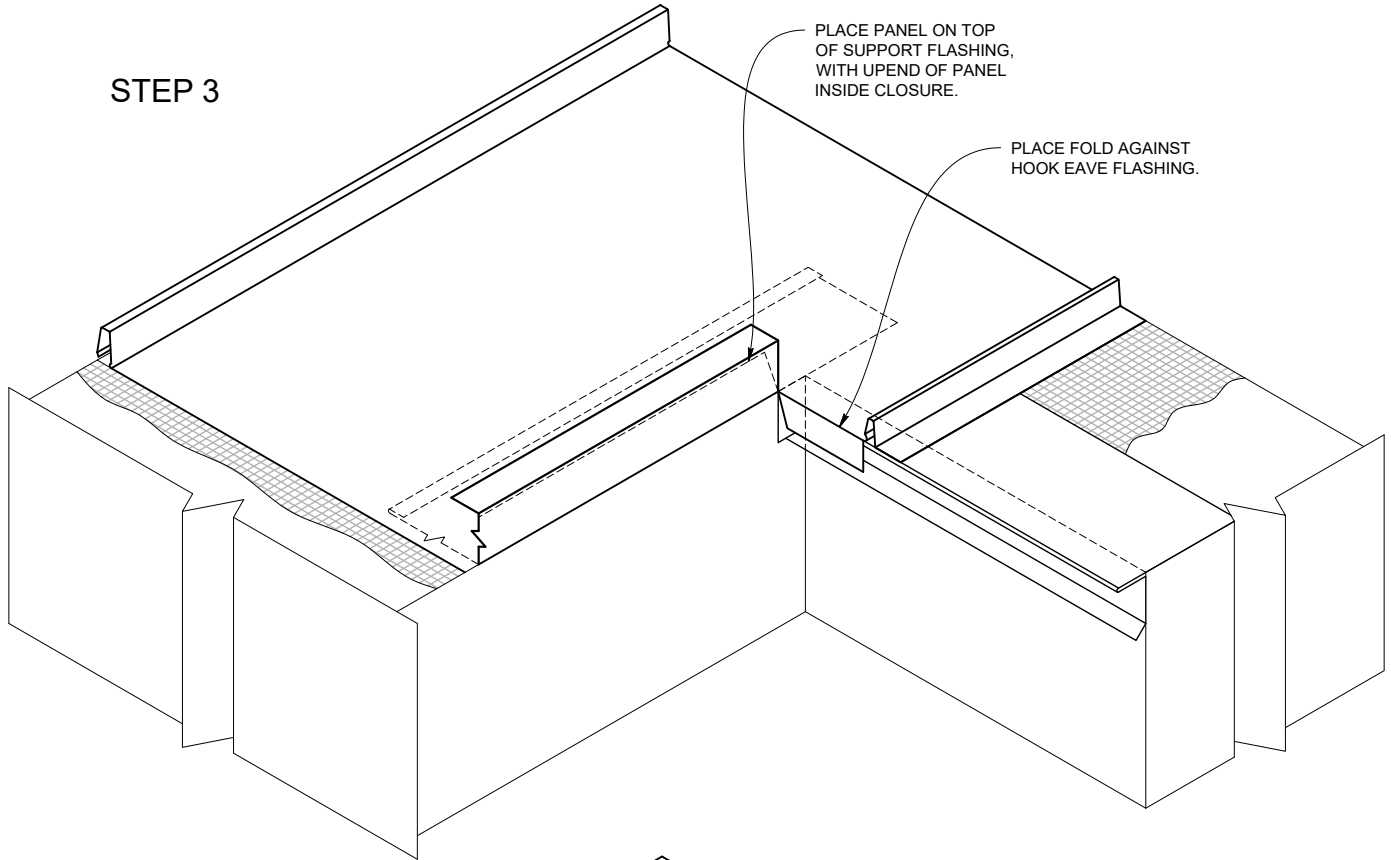

## STEP 4

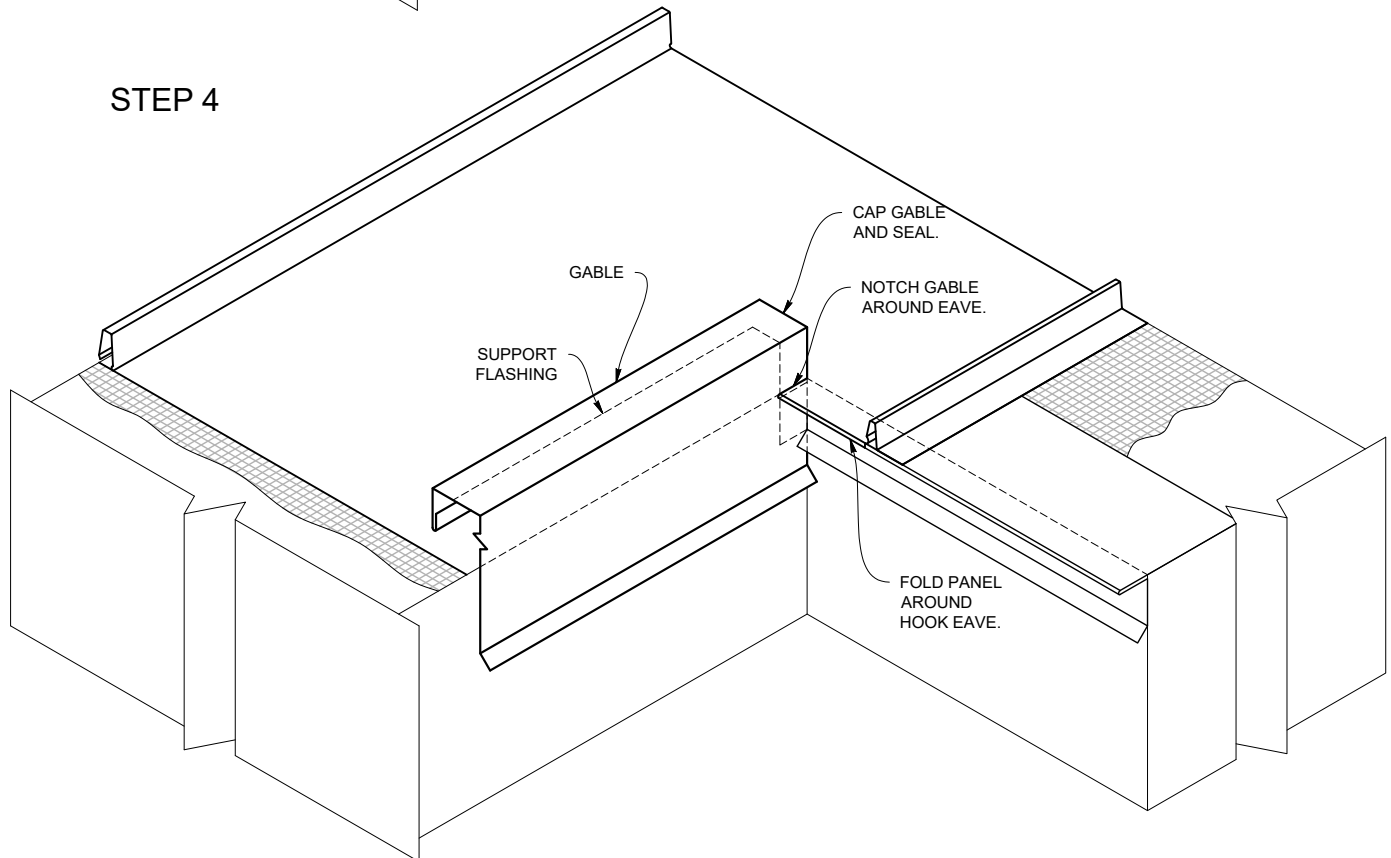

## SKYLIGHT / CHIMNEY TRIM

### For 2" X 4" Curbing

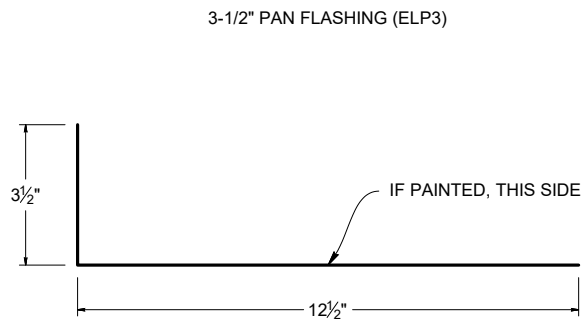

### 2-1/2" SIDE AND BOTTOM FLASHING (ELSB3)

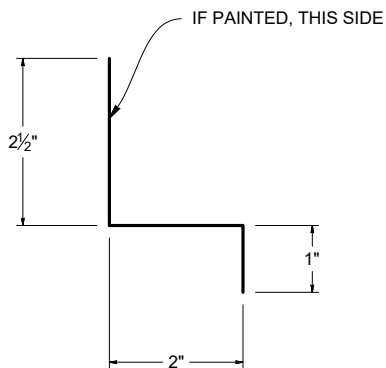

### For 2" X 6" Curbing

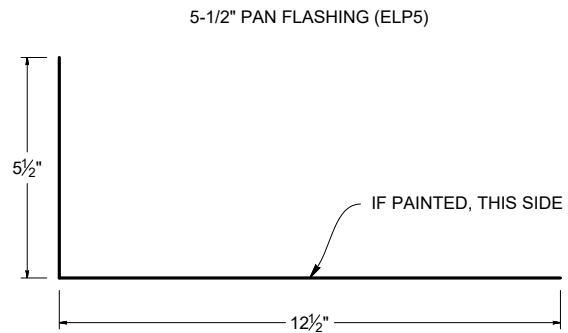

### 5-1/2" SIDE AND BOTTOM FLASHING (ELSB5)

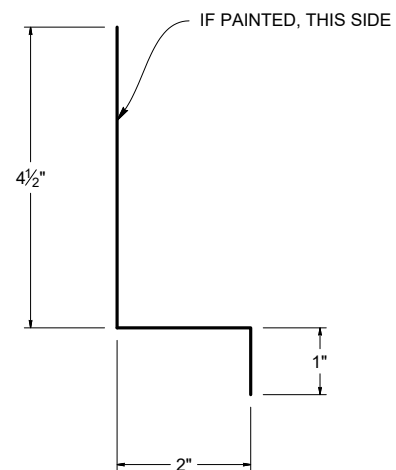

*Apply parts as described on the following pages. Please note that the 12-inch leg of the pan flashing used on a chimney application will need to be bent to the pitch of the roof.*



The following instructions are applicable to most typical skylight or chimney applications. However, your individual application may be unique and require custom flashing and/or special installation. Be sure to check with the skylight manufacturer to determine recommended flashing and whether deviation will result in nullifying your warranty. The use of a cricket is advised in some situations, especially where the drainage is into a curb that exceeds 2'6", or if the roof area will have a lot of debris falling on it. Crickets are specially made to fit the curb/chimney and are used in place of the head flashing. Installation information for the cricket and the head flashing is the same.

## Skylight / Chimney Application

*Dotted lines show where to cut.*

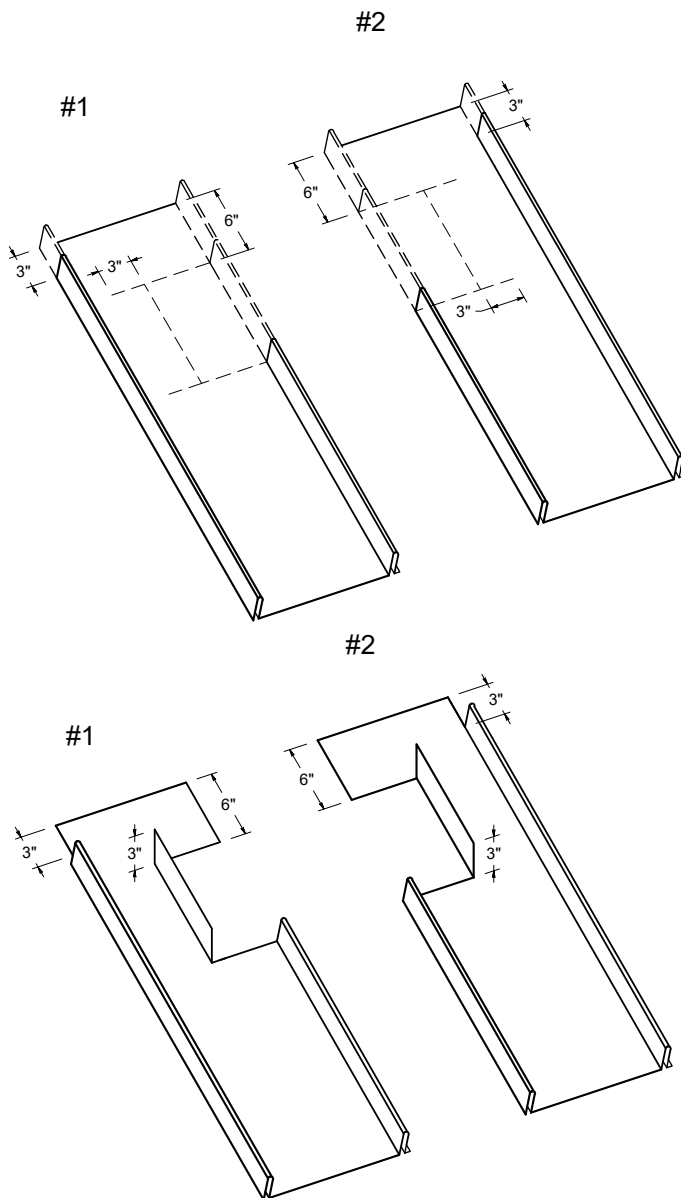

**Parts shown after they have been cut and bent.**

**Step 1:** Working from left to right, cut to fit, bend and install panel #1.

**Step 2:** Cut to fit, bend and install panel #2. *(Install additional panels as normal, between panels #1 and #2, as needed to cover width of skylight/chimney opening).*

**Step 3:** The next piece to install is the pan flashing #3. First place a bead of skinning butyl sealant on top of panel #1 and #2 to stop any water from siphoning at the joint. Next, cut and bend the pan flashing to fit. The artificial ribs should be 1/2" high. Set and fasten.

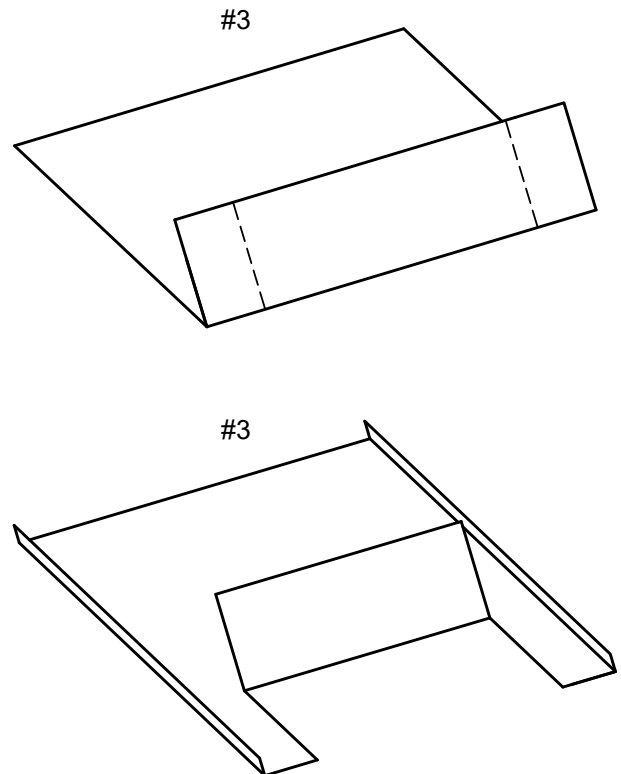

**#3 is the Pan flashing. Order the proper size for the curb height of your skylight, 5-1/2" (ELP5) or 3-1/2" (ELP3).**

# Skylight / Chimney



**ROLLED STEEL PRODUCTS**  
a Taylor Metal Company

*Dotted lines show where to cut.*

#5

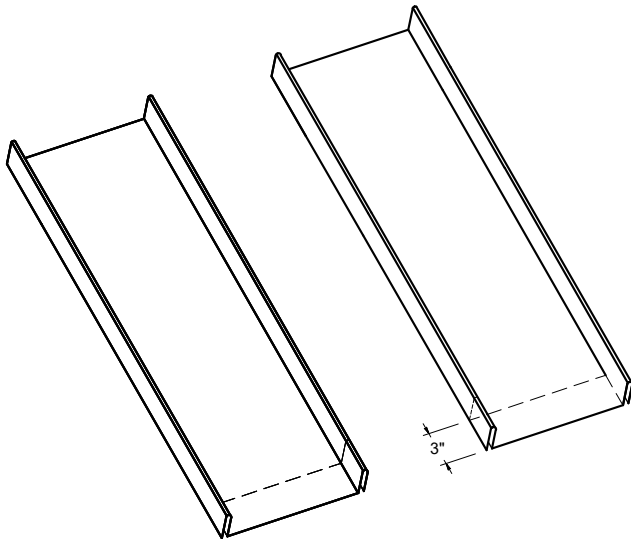

#5

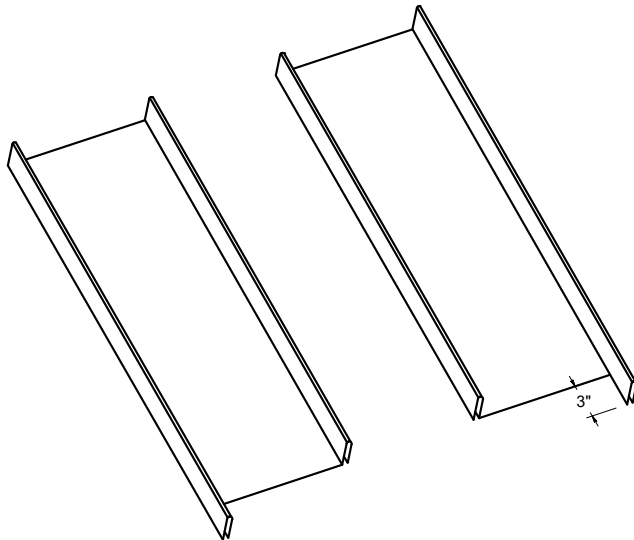

*Parts shown after they have been cut.*

**Step 4:** Working from left to right, cut and install panel #4, snapping it into place and continue fastening as usual.

**Step 5:** Cut and install panel #5. (Install additional panels as normal, between panels #1 and #2, as needed to cover width of skylight/chimney opening).

**Step 6:** Install the bottom flashing #6 as you would the standard endwall flashing. Next, apply sidewall flashing #7 and #8 finishing off around the curb of the skylight.

*Note: Skinning butyl sealant should be used at all joints and where the metal is to be overlapped.*

*Note: The care and attention to detail that is used when installing the flashings determines the overall finished appearance.*

*Note: The preceding information is designed as a general guideline to be used and is not the only acceptable method to flash a skylight.*

38

Parts #6, #7 and #8 are all the Sidewall flashing (ELSB5 or EL SB3). The only difference is the way they are cut and bent on the job. Again, order the proper size curb height of your skylight.

*Dotted lines show where to cut*

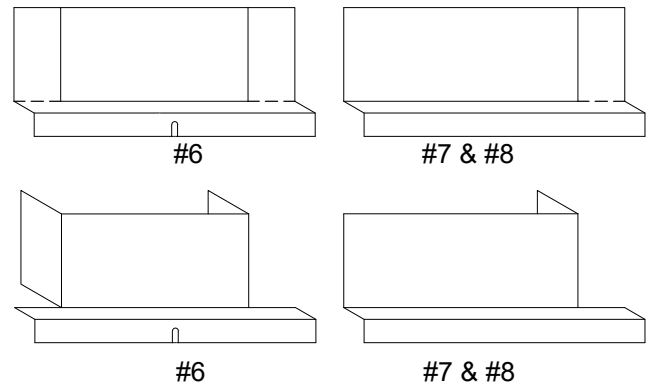

*Parts shown after they have been cut and bent.*

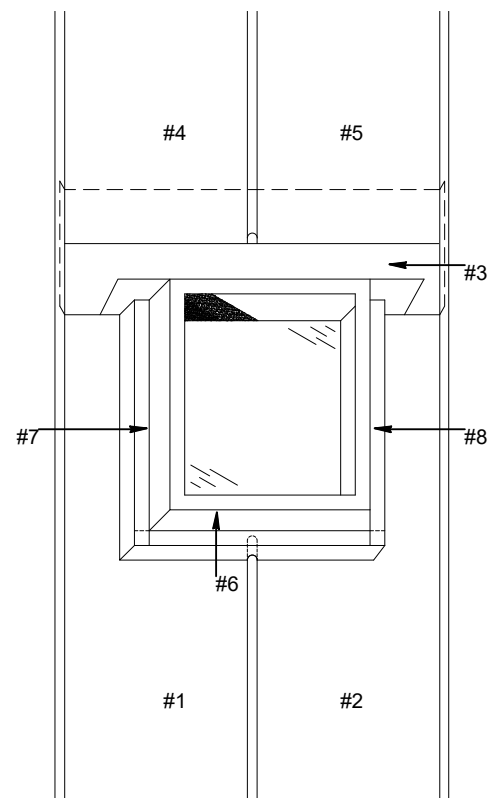

**Diagram of part placement around the skylight.**



**FOR PIPES LOCATED 20' OR GREATER FROM PIN POINT**  
Allows panel and pipe flashing to move with temperature change.

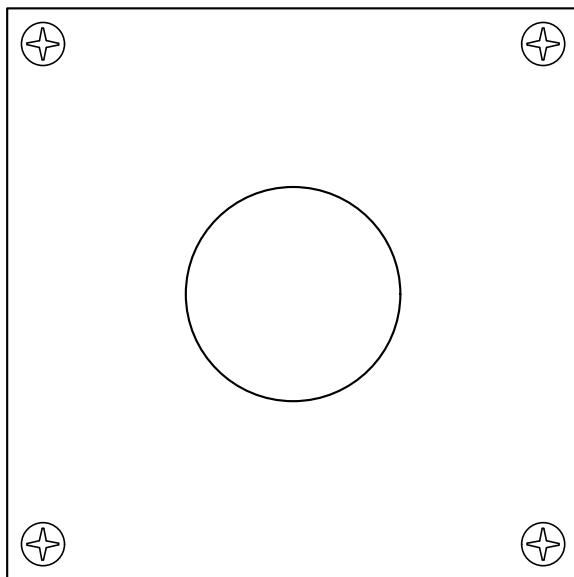
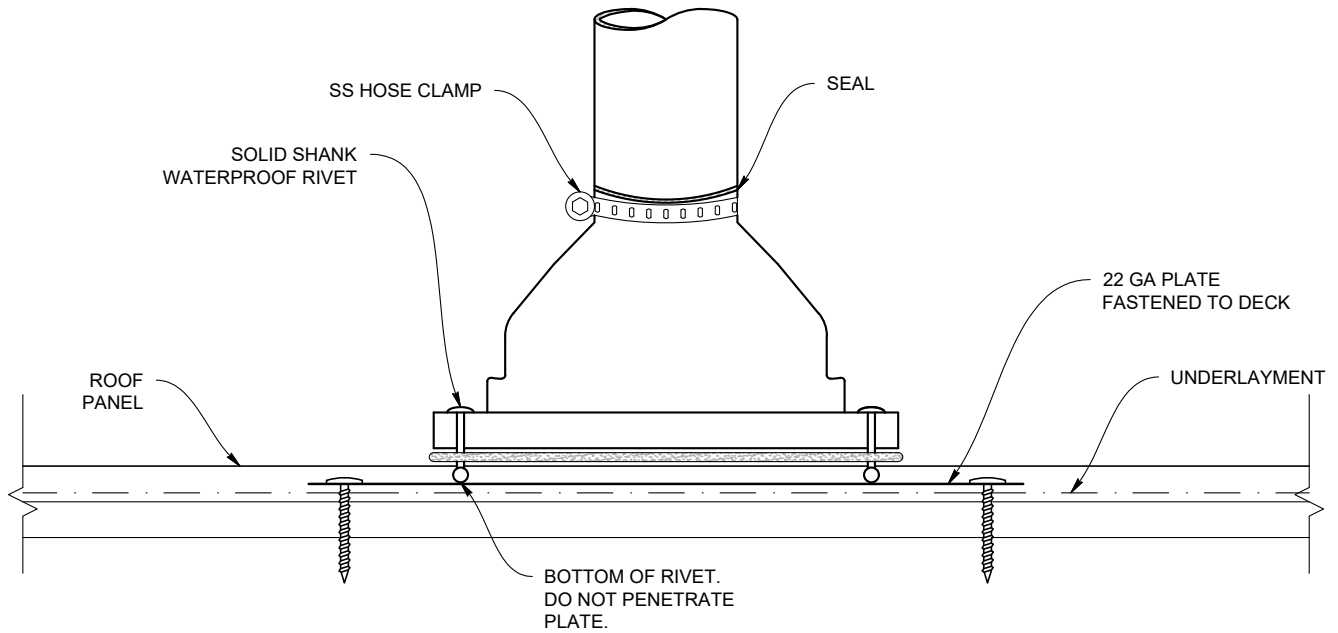

SINGLE 22 GAUGE PLATE

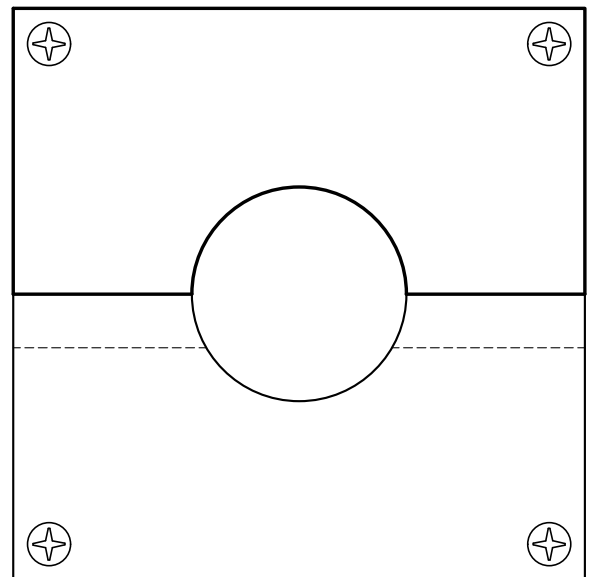

TWO OVERLAPPING 22 GAUGE PLATES

# Pipe Penetration On Rib



**ROLLED STEEL PRODUCTS**  
*a Taylor Metal Company*

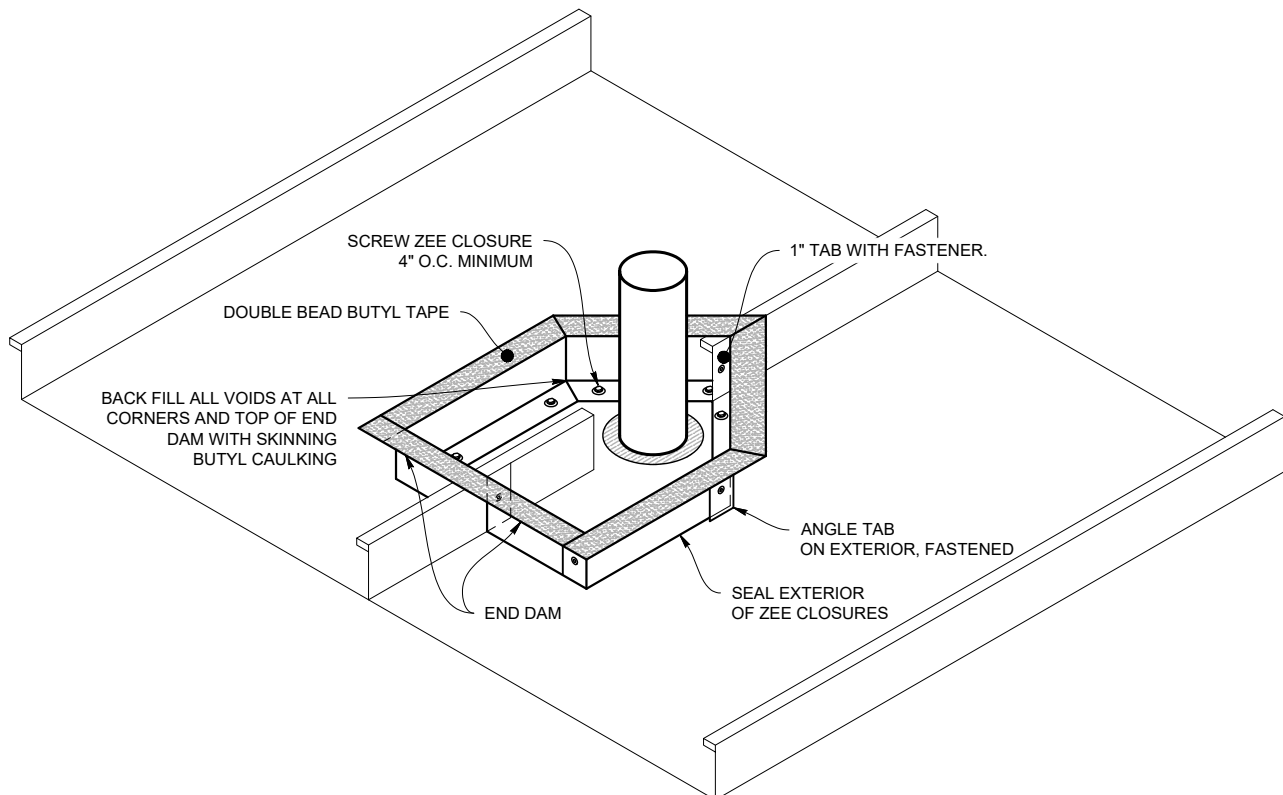
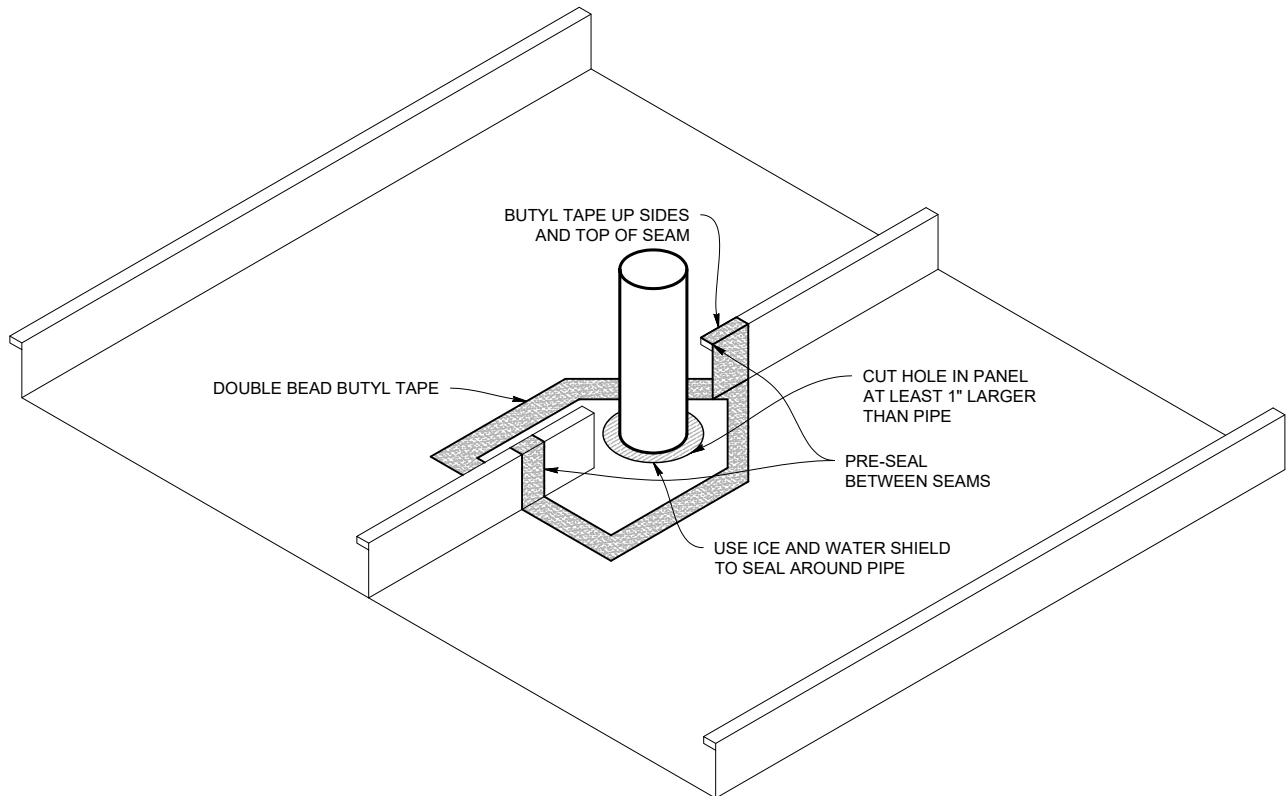



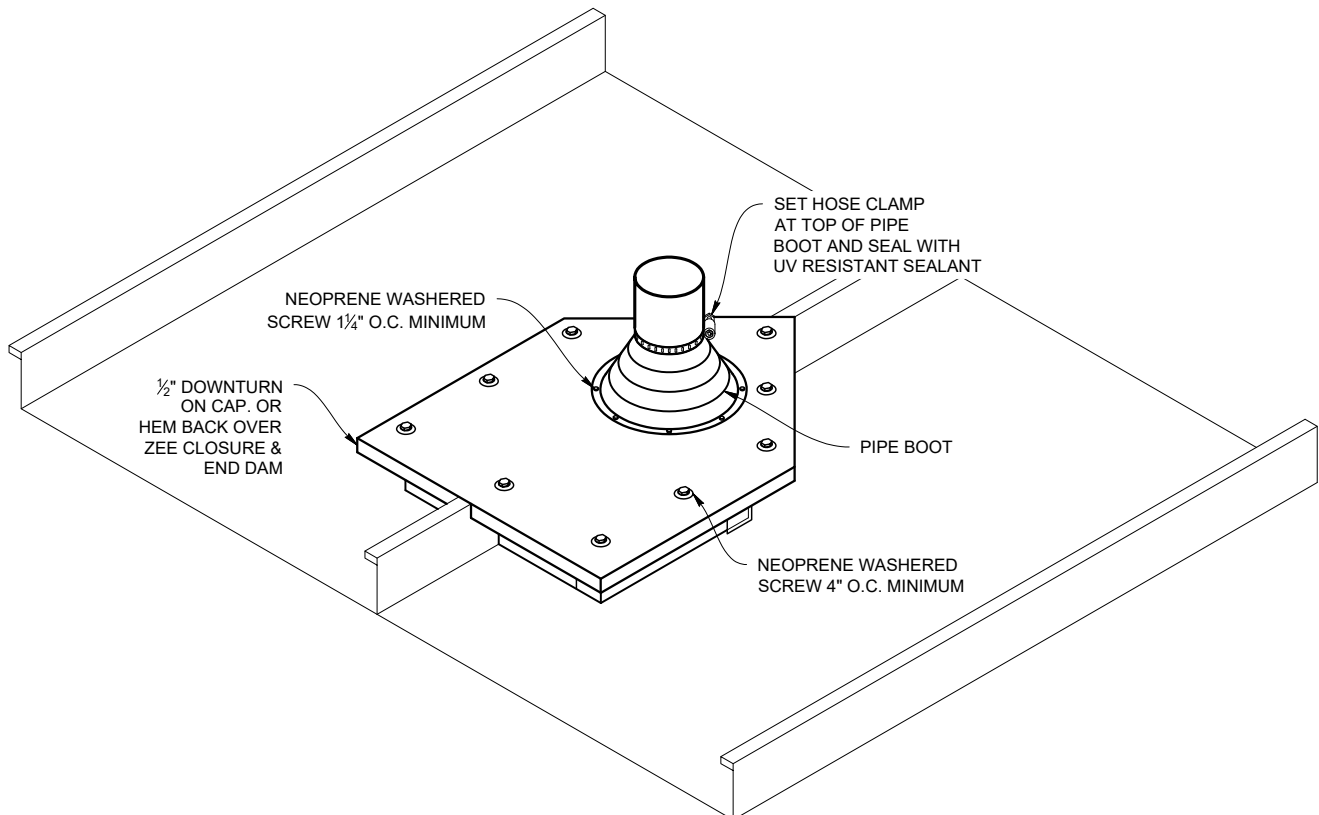
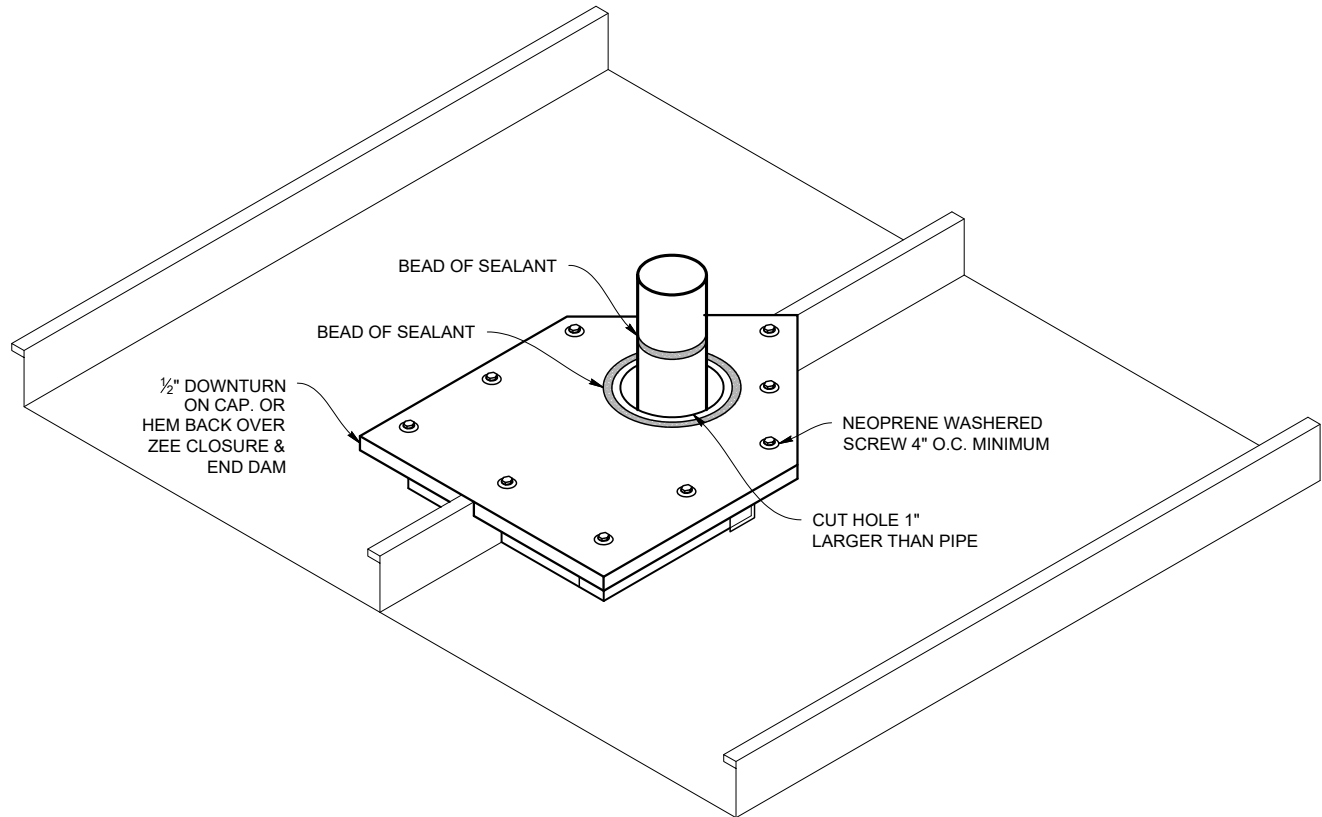

# Pipe Penetration On Pan



**ROLLED STEEL PRODUCTS**  
*a Taylor Metal Company*

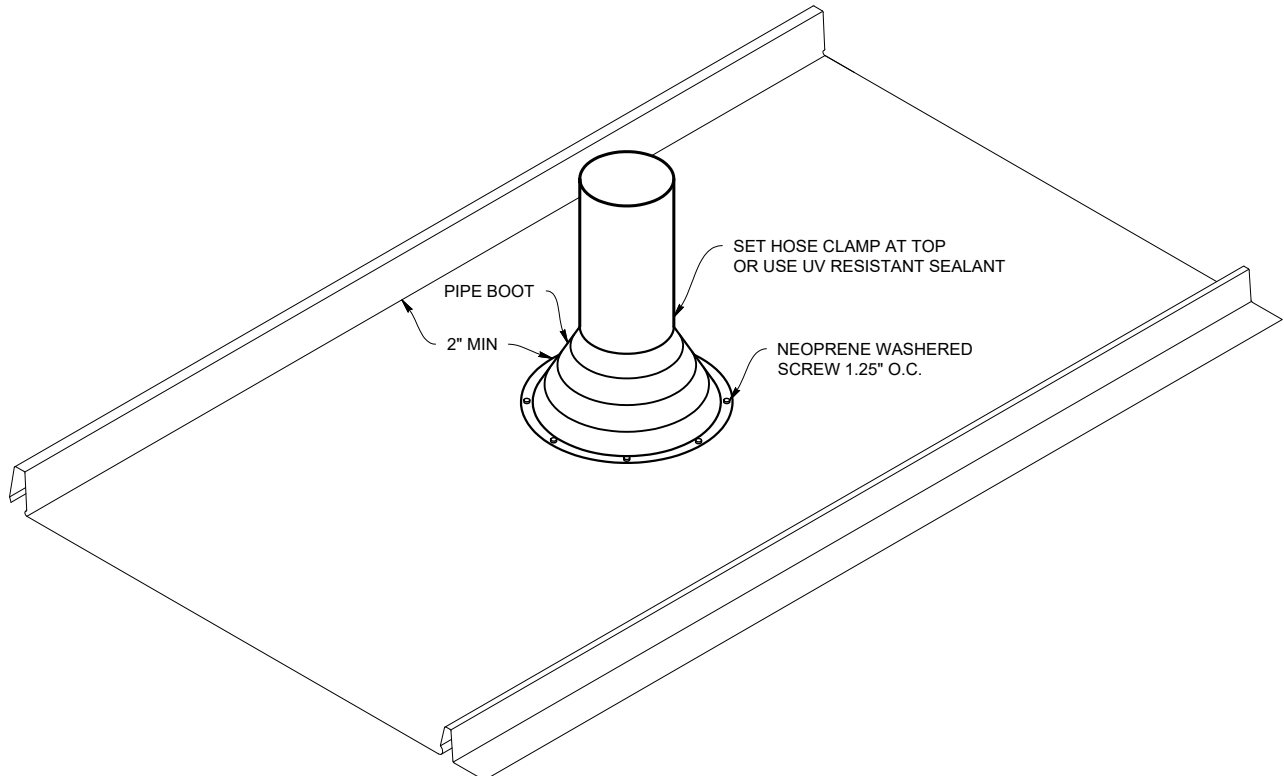
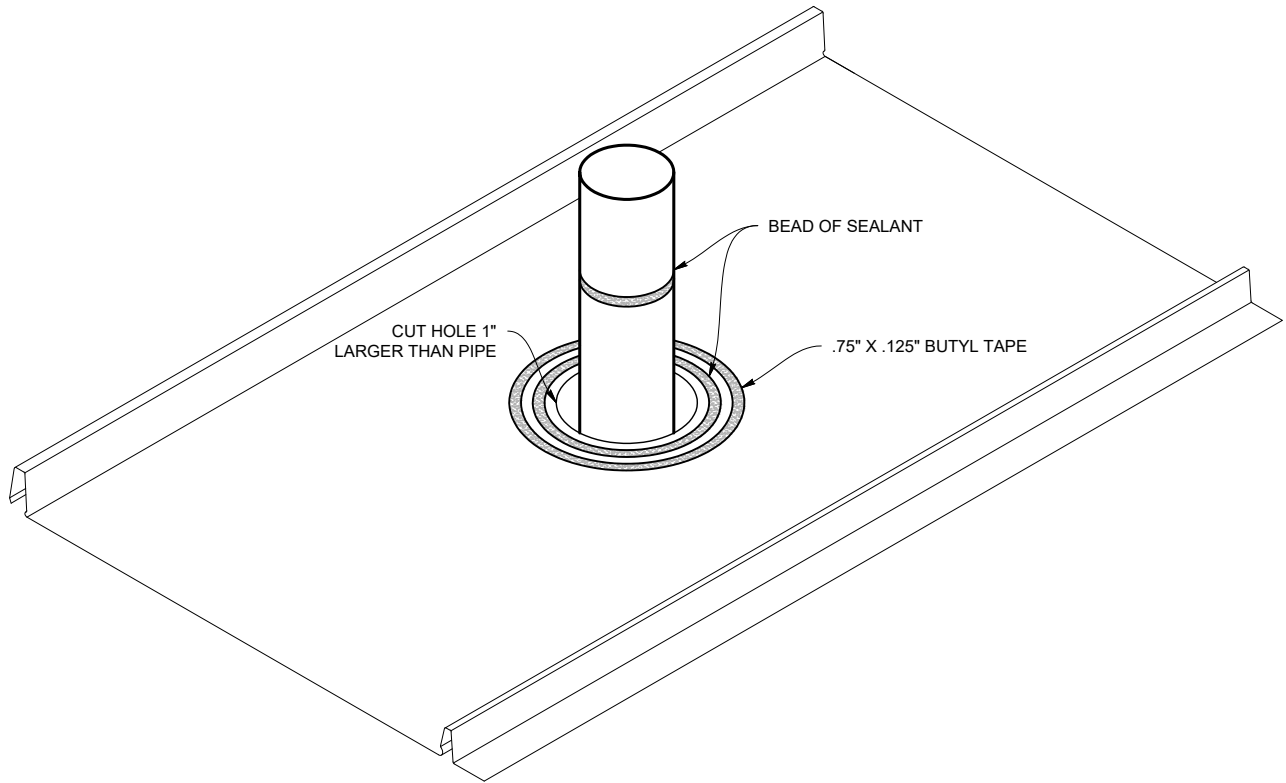

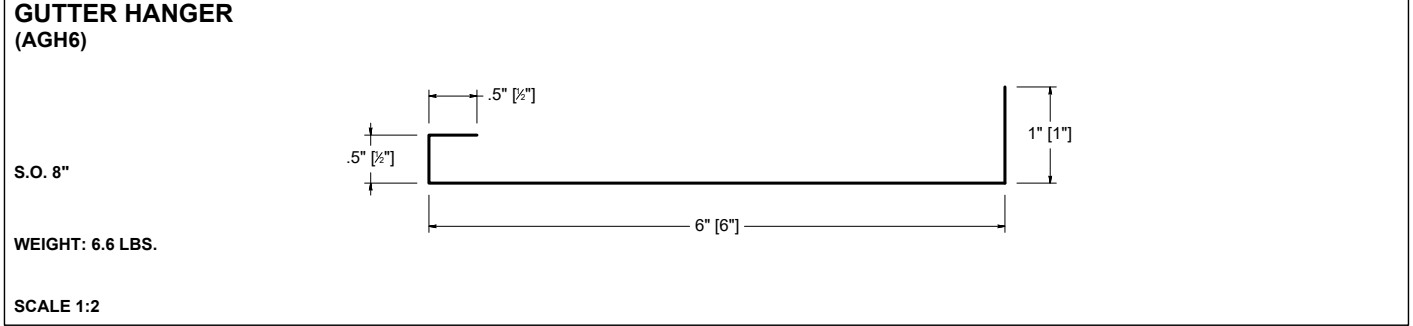
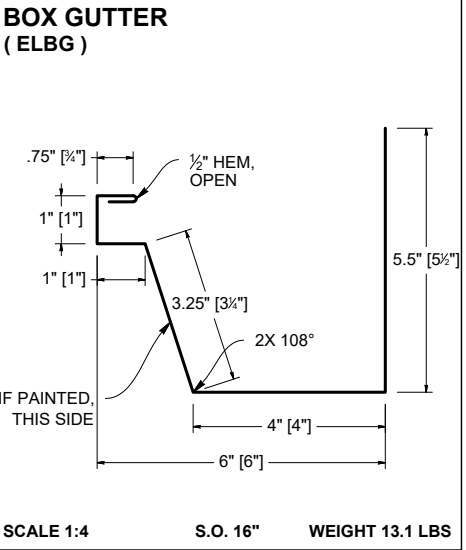
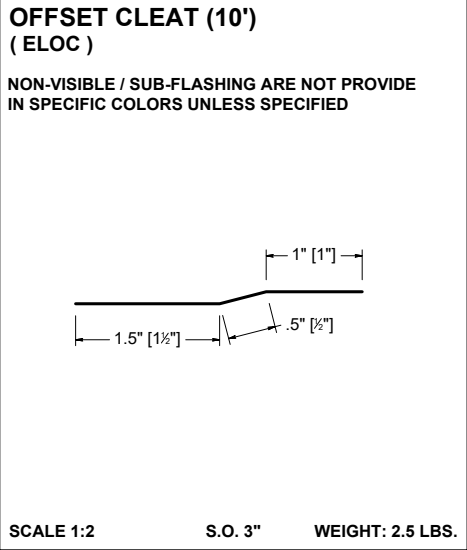
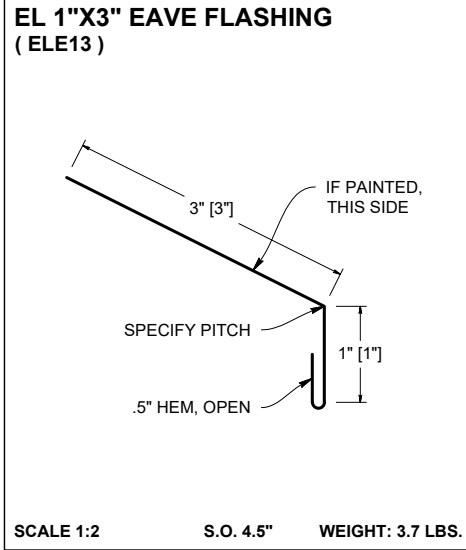
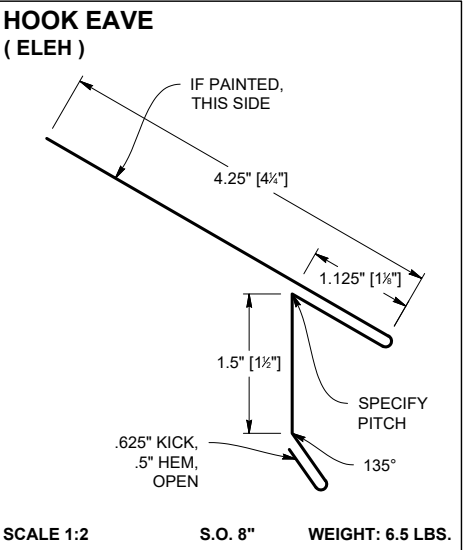
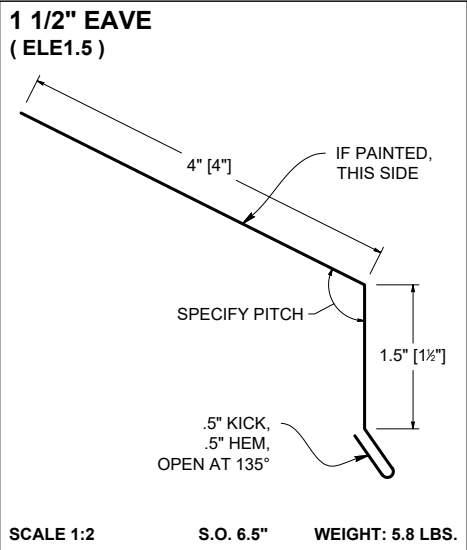
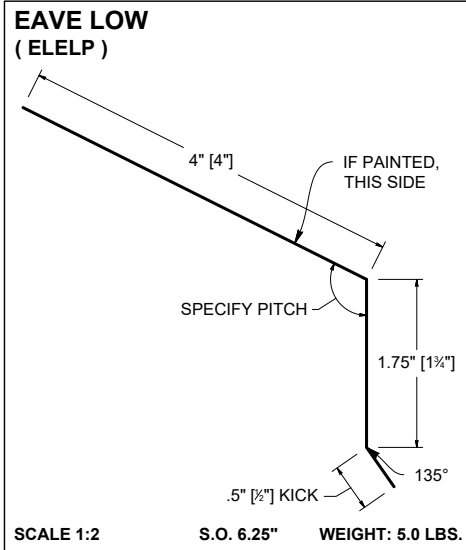



<p><b>NARROW GABLE</b> ( ELGN )</p> <p>SCALE 1:3      S.O. 5.5625"      WEIGHT: 4.7 LBS.</p>	<p><b>COMPENSATING GABLE</b> ( ELGC )</p> <p>SCALE 1:3      S.O. 7.9375"      WEIGHT: 6.6 LBS.</p>	<p><b>COMPENSATING GABLE HEMMED</b> ( ELGCH )</p> <p>SCALE 1:3      S.O. 8.9375"      WEIGHT: 7.9 LBS.</p>
<p><b>GABLE G-17</b> ( ELGG17 )</p> <p>SCALE 1:3      S.O. 9.75"      WEIGHT: 8 LBS.</p>	<p><b>BOX GABLE</b> ( ELGB )</p> <p>SCALE 1:3      S.O. 8.375"      WEIGHT: 6.9 LBS.</p>	<p><b>BOX GABLE NO HEM</b> ( ELGBNH )</p> <p>SCALE 1:3      S.O. 7.375"      WEIGHT: 6.1 LBS.</p>
<p><b>SUPPORT FLASHING (10')</b> ( ELSF )</p> <p>NON-VISIBLE / SUB-FLASHING ARE NOT PROVIDE IN SPECIFIC COLORS UNLESS SPECIFIED</p> <p>SCALE 1:2      S.O. 6.125"      WEIGHT: 5.1 LBS.</p>	<p><b>GABLE CLEAT (10')</b> ( ELBGC )</p> <p>NON-VISIBLE / SUB-FLASHING ARE NOT PROVIDE IN SPECIFIC COLORS UNLESS SPECIFIED</p> <p>SCALE 1:2      S.O. 5.375"      WEIGHT: 4.4 LBS.</p>	<p><b>PROW</b> ( ELPF )</p> <p>SCALE 1:6      S.O. 20"      WEIGHT: 16.3LBS.</p>



<p><b>FIELD NOTCHED RIDGE (UNVENTED) (ELRS)</b></p> <p>6" [6"] 6.25" [5/8"] .875" [7/8"] 7.5° [3/4"] IF PAINTED, THIS SIDE SPECIFY PITCH</p> <p>SCALE 1:4      S.O. 16.5"      WEIGHT: 13.7 LBS.</p>	<p><b>RIDGE FULL VENTED (ELRFV)</b></p> <p>7" [7"] .75" [3/4"] .625" [5/8"] IF PAINTED, THIS SIDE SPECIFY PITCH</p> <p>SCALE 1:5      S.O. 16.75"      WEIGHT: 13.7 LBS.</p>	
<p><b>R-17 RIDGE (ELR17)</b></p> <p>7.125" [7 1/4"] 1.125" [1 1/4"] 117° TYP. UNLESS NOTED .5" OPEN HEM IF PAINTED, THIS SIDE SPECIFY PITCH</p> <p>SCALE 1:5      S.O. 20"      WEIGHT: 16.1 LBS.</p>	<p><b>VENTED PEAK FLASHING (ELRECV)</b></p> <p>6" [6"] 1.125" [1 1/4"] 5.25" [5 1/4"] .5" [1/2"] 7.5" [3/4"] IF PAINTED, THIS SIDE SPECIFY PITCH SLIGHTLY OPEN HEM .5" KICK, .5" HEM AT 135°</p> <p>S.O. 14.625" WEIGHT: 11.9 LBS.</p> <p>SCALE 1:4</p>	
<p><b>PEAK CLEAT (ELRECC)</b></p> <p>1" [1"] 4.125" [4 1/4"] .5" KICK 135° SPECIFY PITCH</p> <p>NON-VISIBLE SUB-FLASHING ARE NOT PROVIDE IN SPECIFIC COLORS UNLESS SPECIFIED</p> <p>FOR USE WITH HEMMED AND FIELD NOTCHED PEAK FLASHINGS ONLY</p> <p>SCALE 1:3      S.O. 5.625"      WEIGHT: 4.5 LBS.</p>	<p><b>HEMMED PEAK FLASHING (ELRECH)</b></p> <p>6" [6"] 1" [1"] 4.25" [4 1/4"] IF PAINTED, THIS SIDE SPECIFY PITCH SLIGHTLY OPEN HEM .5" KICK, .5" HEM AT 135°</p> <p>SCALE 1:4      S.O. 11.75"      WEIGHT: 9.6 LBS.</p>	<p><b>FIELD NOTCHED PEAK FLASHING (ELREC)</b></p> <p>5.75" [5 3/4"] 7/8" 4.25" [4 1/4"] IF PAINTED, THIS SIDE SPECIFY PITCH .5" KICK, .5" HEM AT 135°</p> <p>SCALE 1:4      S.O. 11.875"      WEIGHT: 9.8 LBS.</p>
<p><b>FIELD NOTCHED HIP (ELHS)</b></p> <p>5" [5"] .625" [5/8"] .875" [7/8"] .75" [3/4"] IF PAINTED, THIS SIDE SPECIFY PITCH</p> <p>SCALE 1:4      S.O. 14.5"      WEIGHT: 12.1 LBS.</p>	<p><b>HIP/RIDGE (SPECIFY) (ELHR)</b></p> <p>5.625" [5 5/8"] 1" HEM, OPEN IF PAINTED, THIS SIDE SPECIFY PITCH</p> <p>SCALE 1:4      S.O. 13.25"      WEIGHT: 10 LBS.</p>	



### VALLEY FLASHING 24" HEMMED (ELVF24H)

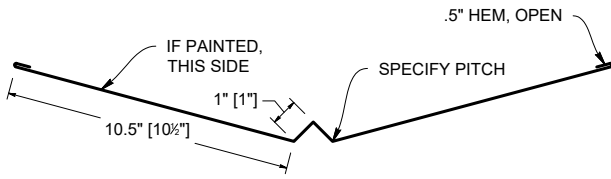

SCALE 1:7

S.O. 24"

WEIGHT: 19.6 LBS.

### VALLEY FLASHING 24" (ELVF24)

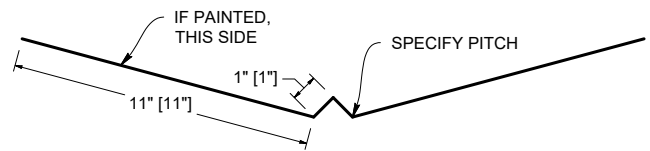

SCALE 1:7

S.O. 24"

WEIGHT: 19.6 LBS.

### VALLEY WIDE FLASHING (ELVFW)

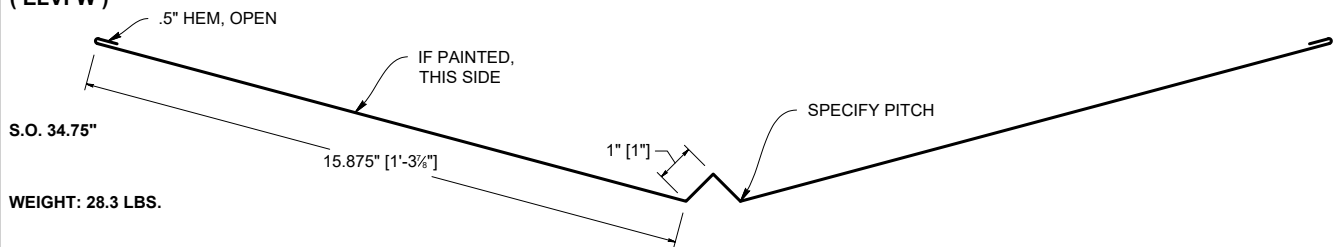

S.O. 34.75"

WEIGHT: 28.3 LBS.

SCALE 1:5

### FIELD NOTCHED INSIDE PITCH CHANGE (ELPCIN)

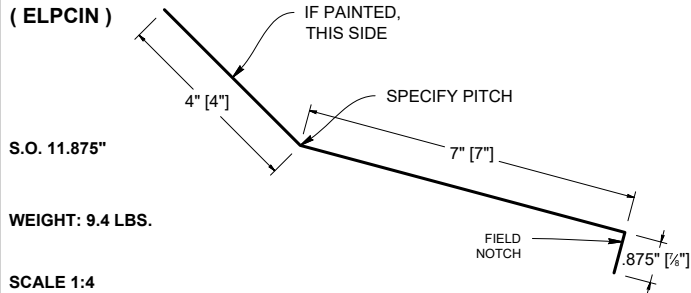

S.O. 11.875"

WEIGHT: 9.4 LBS.

SCALE 1:4

### FIELD NOTCHED OUTSIDE PITCH CHANGE (ELPCON)

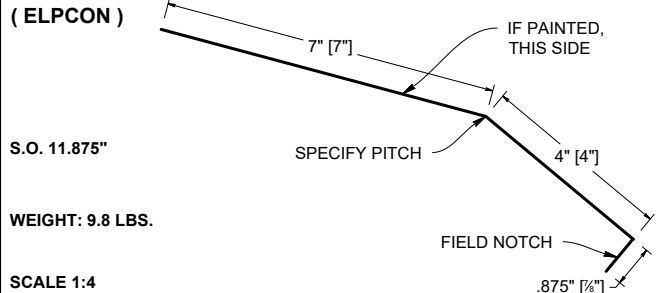

S.O. 11.875"

WEIGHT: 9.8 LBS.

SCALE 1:4

### OUTSIDE PITCH CHANGE HEMMED (ELPCOH)

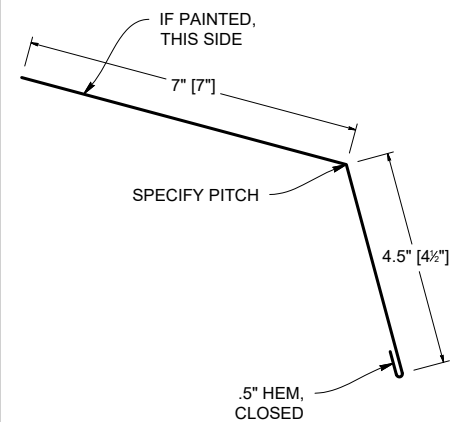

SCALE 1:4

S.O. 12"

WEIGHT: 9.8 LBS.

### INSIDE PITCH CHANGE HEMMED (ELPCIH)

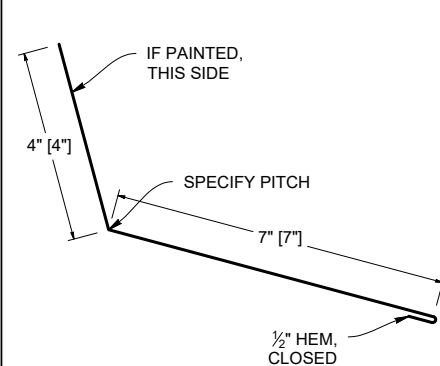

SCALE 1:4

S.O. 11.5"

WEIGHT: 8.6 LBS.

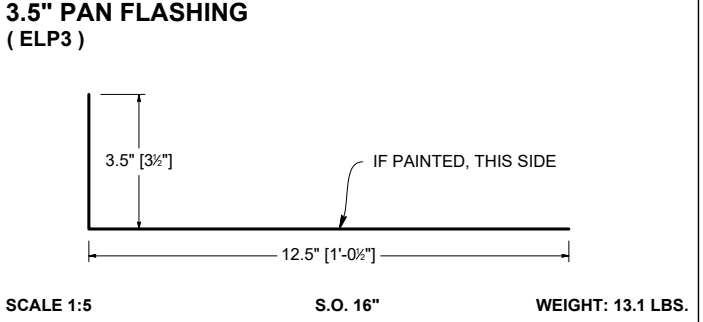
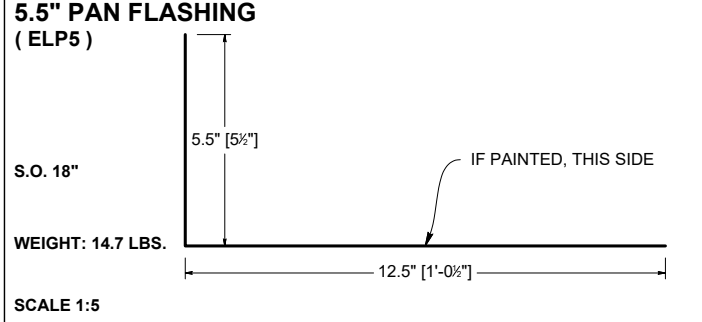
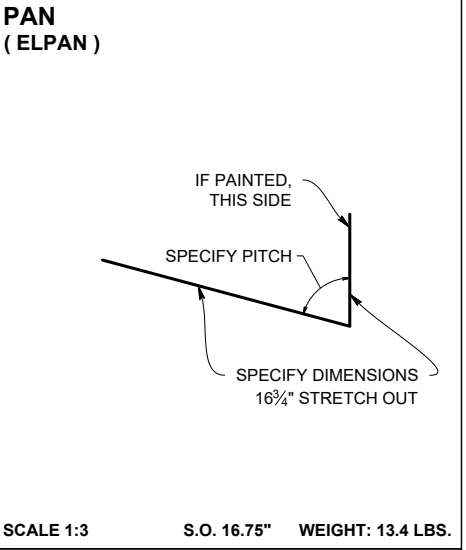
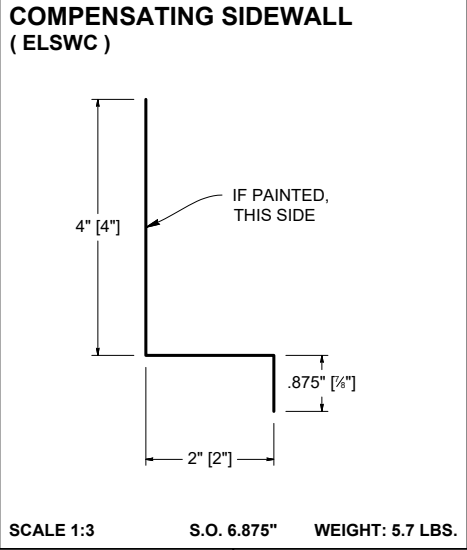
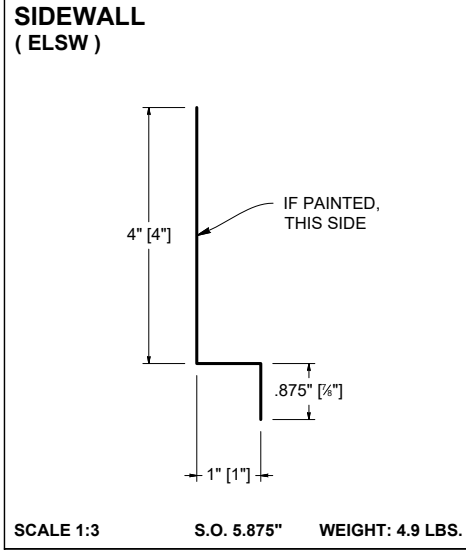
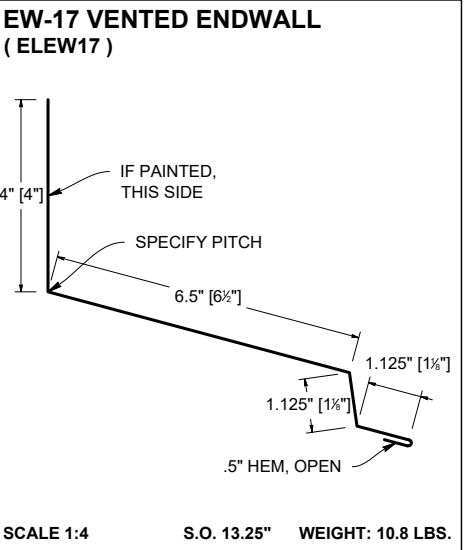
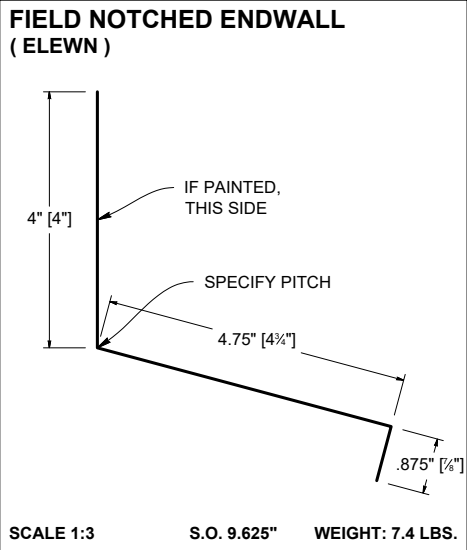
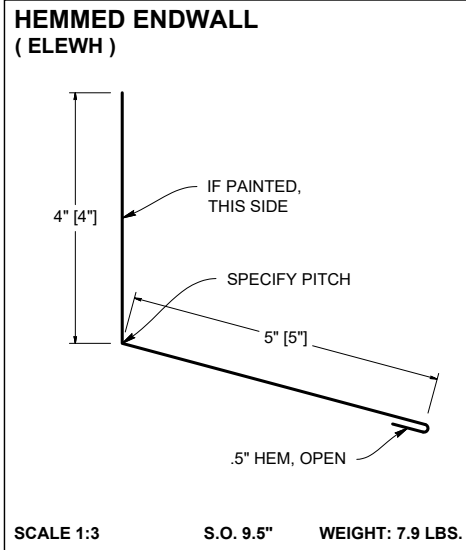



<p><b>C- FLASHING (ELCF)</b></p> <p>SCALE 1:2      S.O. 5.375"      WEIGHT: 4.5 LBS.</p>	<p><b>ZEE CLOSURE (ELZC)</b></p> <p>SCALE 1:2      S.O. 2.875"      WEIGHT: 2.64 LBS.</p>	
<p><b>4" PERF STRIP (ELPS)</b>      ONLY IN 24 GA ZINCALUM</p> <p>SCALE 1:2      S.O. 4"      WEIGHT: 2.5 LBS.</p>	<p><b>REVERSING STRIP (ELSR)</b></p> <p>SCALE 1:1      S.O. 2"      WEIGHT: 1.7 LBS.</p>	
<p><b>OFFSET CLEAT (10') (ELOC)</b></p> <p>NON-VISIBLE SUB-FLASHING ARE NOT PROVIDE IN SPECIFIC COLORS UNLESS SPECIFIED</p> <p>SCALE 1:2      S.O. 3"      WEIGHT: 2.5 LBS.</p>	<p><b>GABLE CLEAT (10') (ELBGC)</b></p> <p>NON-VISIBLE SUB-FLASHING ARE NOT PROVIDE IN SPECIFIC COLORS UNLESS SPECIFIED</p> <p>SCALE 1:2      S.O. 5.375"      WEIGHT: 4.4 LBS.</p>	<p><b>PEAK CLEAT (10') (ELRECC)</b></p> <p>NON-VISIBLE SUB-FLASHING ARE NOT PROVIDE IN SPECIFIC COLORS UNLESS SPECIFIED</p> <p>SPECIFY PITCH</p> <p>SCALE 1:2      S.O. 5.625"      WEIGHT: 4.7 LBS.</p>
<p><b>EASY-LOCK END DAM</b></p> <p>S.O. 8"</p> <p>WEIGHT: 6.5 LBS.</p>		





**EASY LOCK OUTSIDE CORNER (ELCOA)**

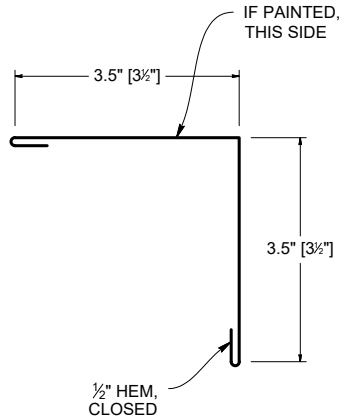

SCALE 1:3 S.O. 8" WEIGHT: 6.6 LBS

**EASY LOCK INSIDE CORNER (ELCIA)**

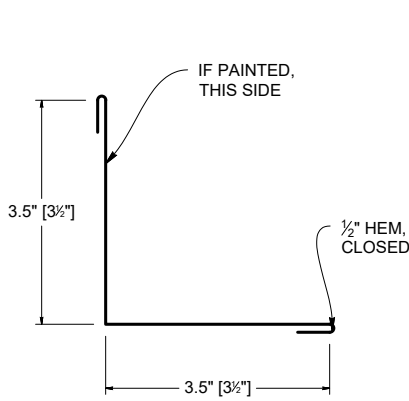

SCALE 1:3 S.O. 8" WEIGHT: 6.6 LBS

**EASY LOCK BASE FLASHING (ELBF)**

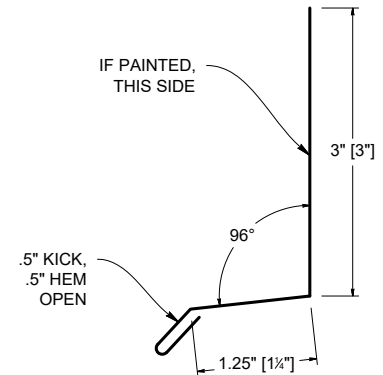

SCALE 1:2 S.O. 5.25" WEIGHT: 4.3 LBS

**EASY LOCK OUTSIDE CORNER POST (ELCPO)**

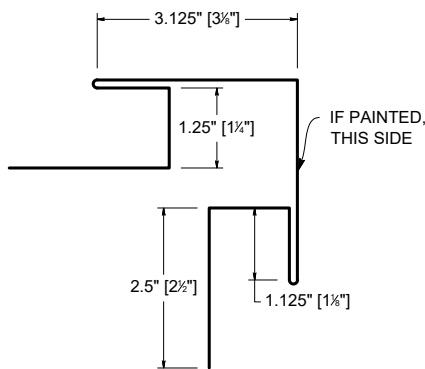

SCALE 1:3 S.O. 16" WEIGHT: 13.1 LBS

**EASY LOCK INSIDE CORNER POST (ELCPI)**

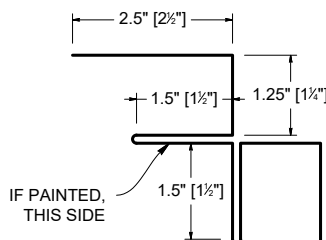

SCALE 1:3 S.O. 13.5" WEIGHT: 10.9 LBS

**EASY LOCK ZEE FLASHING HEMMED (ELZFH)**

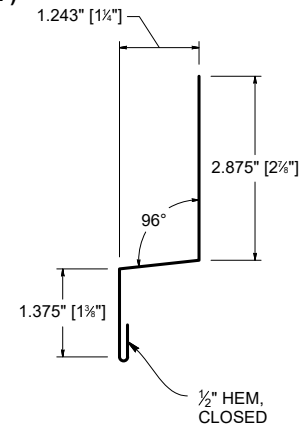

SCALE 1:3 S.O. 6" WEIGHT: 4.5 LBS

**C- FLASHING HEMMED (ELCF)**

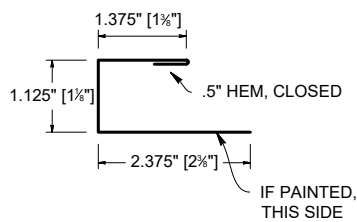

SCALE 1:3 S.O. 5.375" WEIGHT: 4.5 LBS

**2 1/2 SIDE AND BOTTOM FLASHING (ELSB3)**

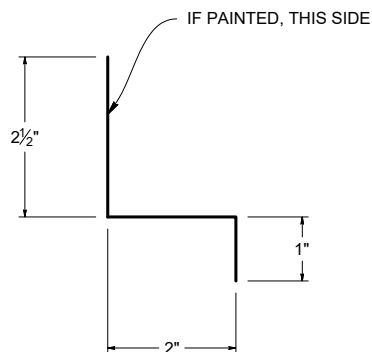

SCALE 1:3 S.O. 5.5" WEIGHT:

**4 1/2 SIDE AND BOTTOM FLASHING (ELSB5)**

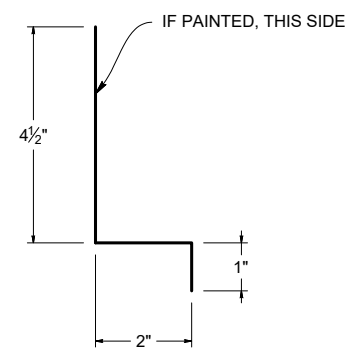

SCALE 1:4 S.O. 7.5" WEIGHT:



# ROLLED STEEL PRODUCTS ORDER FORM

Company: \_\_\_\_\_ Job Name / PO#: \_\_\_\_\_

Contact Person: \_\_\_\_\_ Phone: \_\_\_\_\_

Delivery Address: \_\_\_\_\_

(Address - City - State - Zip)

### PLEASE CALL AHEAD & PRESCHEDULE YOUR DELIVERY DATE

METAL MATERIALS LIST Requested Delivery Date: \_\_\_\_\_

MATERIAL DELIVERED WITH YOUR ORDER →	TRUSSES	LUMBER	INS	MISC
VENDOR →				

PROFILE (CIRCLE ONE/FILL IN): ROLLED RIB 36" 29ga / LOC RIB 16" 26ga / PBR 36" 26ga / R-PANEL 36" 29ga / SL-15 15" 26ga / SW-16 16" 26 ga (VENTED OR NONVENTED)

<b>SIDEWALLS</b> COLOR _____	<b>ROOF</b> COLOR _____
PCS PROFILE: _____	PCS PROFILE: _____
_____ @ _____	_____ @ _____
_____ @ _____	_____ @ _____
_____ @ _____	_____ @ _____
_____ @ _____	_____ @ _____

### ACCESSORIES

(10'-6" STANDARD, 12'-2" OPTIONAL 29 GA ONLY)

<b>GABLES</b>	COLOR _____	QTY		COLOR	GAUGE
PCS	PROFILE _____				
_____ @ _____		_____	RIDGE CAP (SPECIFY PITCH)	_____	_____
_____ @ _____		_____	LTRC (WIDER - STEEPER PITCH)	_____	_____
_____ @ _____		_____	SOFFIT RIDGE (3')	_____	_____
_____ @ _____		_____	GABLE (SPECIFY TYPE)	_____	_____
_____ @ _____		_____	EAVE (SPECIFY PITCH)	_____	_____
_____ @ _____		_____	10'6" OUTSIDE CORNER	_____	_____
_____ @ _____		_____	12'2" OUTSIDE CORNER	_____	29
_____ @ _____		_____	10'6" C-METAL	_____	_____
_____ @ _____		_____	12'2" C-METAL	_____	29
_____ @ _____		_____	10'6" SOFFIT C-METAL	_____	_____
_____ @ _____		_____	12'2" SOFFIT C-METAL	_____	29
_____ @ _____		_____	BASE METAL	_____	_____
_____ @ _____		_____	WALL LIGHT FLASHING	_____	_____
_____ @ _____		_____	SOFFIT PANELS-RR (SPECIFY WIDTH)	_____	_____
_____ @ _____		_____	10'6" DOOR JAMB (SPECIFY SIZE)	_____	_____
_____ @ _____		_____	12'2" DOOR JAMB (SPECIFY SIZE)	_____	29
_____ @ _____		_____	10'6" OPEN JAMB (SPECIFY SIZE)	_____	_____
_____ @ _____		_____	12'2" OPEN JAMB (SPECIFY SIZE)	_____	29
_____ @ _____		_____	FASCIA TRIM (SPECIFY SIZE)	_____	_____
_____ @ _____		_____	SIDEWALL (90°)	_____	_____
_____ @ _____		_____	END WALL (SPECIFY PITCH)	_____	_____
_____ @ _____		_____	SNOW BREAK	_____	_____
_____ @ _____		_____	SINGLE TRACK COVER	_____	_____
_____ @ _____		_____	DOUBLE TRACK COVER	_____	_____
_____ @ _____		_____	W VALLEY	_____	_____

**SLIDER DOOR METAL** COLOR \_\_\_\_\_

PCS PROFILE \_\_\_\_\_

\_\_\_\_\_ @ \_\_\_\_\_

\_\_\_\_\_ @ \_\_\_\_\_

\_\_\_\_\_ @ \_\_\_\_\_

**SLIDER DOOR PACKAGES**  
(SPECIFY STYKE IF DOOR -SINGLE, SPLIT, ETC.)  
# OF DOORS SIZE

<b>SCREWS</b>	QUANTITY	SIZE	COLOR	QUANTITY	SIZE	COLOR	<b>DRIVER SOCKETS</b>	(QTY)
_____ ROOF	_____	_____	_____	_____ STITCH	3/4"	_____	_____	1/4" HEAD
_____ WALLS	_____	_____	_____	_____ TEKS	1"	_____	_____	1/16" HEAD
_____ TRIM	_____	_____	_____	_____ PANCK	1"	(GALVANIZED ONLY)	_____	PHILLIPS

**MISC.** (PIPE FLASHINGS, ETC.) \_\_\_\_\_ **PAINT PEN:** QTY \_\_\_\_\_ COLOR \_\_\_\_\_ **JOB SIGN:** YES  NO

<b>CLOSURES:</b>	<b>POLYCARBONATE:</b>	<b>UNDERLAYMENT:</b>	<b>2" INSULATION BATTS:</b>
PROFILE: _____	PCS LENGTH	# OF ROLLS	QUANTITY LENGTH (27' 33', OR 44')
QUANTITY	RR CLEAR (2' OR 12')	HYDRASHELL	_____ 6' X _____
_____ INSIDE	RR OPAL (2' OR 12')	ICE & WATER	_____ 6' X _____
_____ OUTSIDE	PBR OPAL (12')	SHIELD	_____ 6' X _____
_____ LP2 VENTED			_____ 4' X _____
_____ UNIVERSAL			_____ 4' X _____
_____ STRIP MASTIC			



# Custom Trim Order

Customer Name: \_\_\_\_\_ Job Name: \_\_\_\_\_

Gauge: \_\_\_\_\_ Color: \_\_\_\_\_ Status:  Original  New

Specify:  Angles  Color Side  Dimensions  Stretchout

SO \_\_\_\_\_

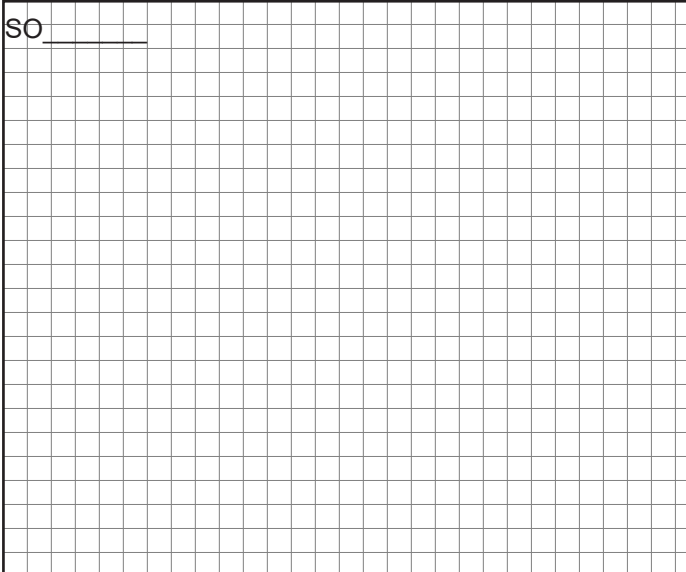

Dwg #: \_\_\_\_\_ Pitch: \_\_\_\_\_ # of Pieces: \_\_\_\_\_

Description: \_\_\_\_\_

Hems:  Open  Closed  Slightly Open

SO \_\_\_\_\_

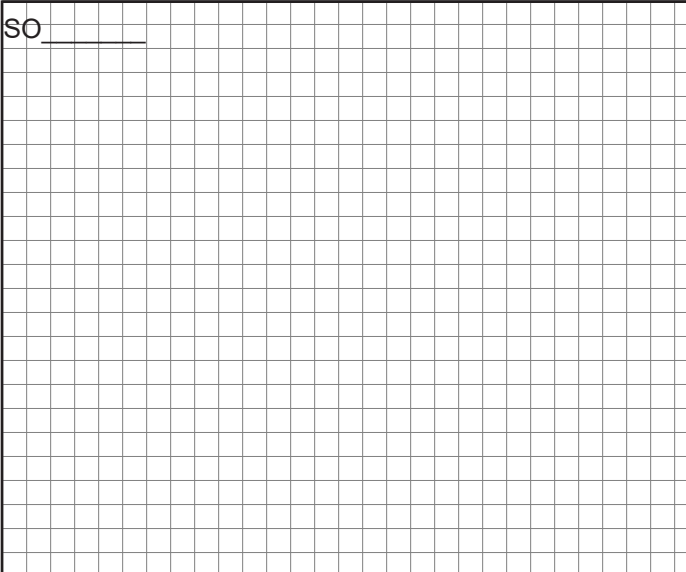

Dwg #: \_\_\_\_\_ Pitch: \_\_\_\_\_ # of Pieces: \_\_\_\_\_

Description: \_\_\_\_\_

Hems:  Open  Closed  Slightly Open

SO \_\_\_\_\_

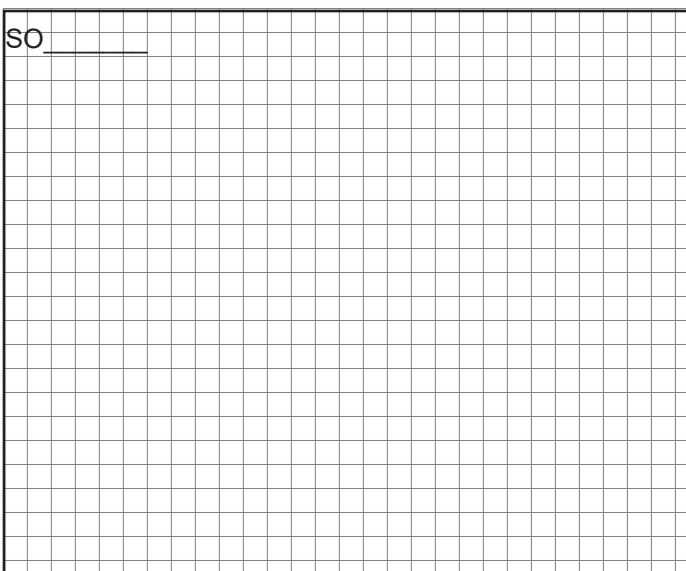

Dwg #: \_\_\_\_\_ Pitch: \_\_\_\_\_ # of Pieces: \_\_\_\_\_

Description: \_\_\_\_\_

Hems:  Open  Closed  Slightly Open

SO \_\_\_\_\_

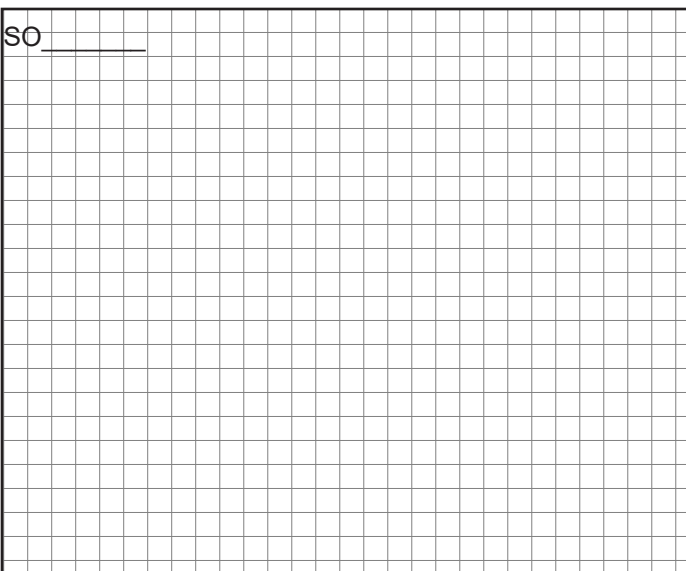

Dwg #: \_\_\_\_\_ Pitch: \_\_\_\_\_ # of Pieces: \_\_\_\_\_

Description: \_\_\_\_\_

Hems:  Open  Closed  Slightly Open

**Please provide a drawing for each flashing with precise measurements and angles**  
Fax to: 503-581-6877

# Custom Trim Order



**ROLLED STEEL PRODUCTS**  
*a Taylor Metal Company*

Customer Name: \_\_\_\_\_ Job Name: \_\_\_\_\_

Gauge: \_\_\_\_\_ Color: \_\_\_\_\_ Status:  Original  New

Specify:  Angles  Color Side  Dimensions  Stretchout

SO \_\_\_\_\_

--

Dwg #: \_\_\_\_\_ Pitch: \_\_\_\_\_ # of Pieces: \_\_\_\_\_

Description: \_\_\_\_\_

Hems:  Open  Closed  Slightly Open

SO \_\_\_\_\_

--

Dwg #: \_\_\_\_\_ Pitch: \_\_\_\_\_ # of Pieces: \_\_\_\_\_

Description: \_\_\_\_\_

Hems:  Open  Closed  Slightly Open

SO \_\_\_\_\_

--

Dwg #: \_\_\_\_\_ Pitch: \_\_\_\_\_ # of Pieces: \_\_\_\_\_

Description: \_\_\_\_\_

Hems:  Open  Closed  Slightly Open

SO \_\_\_\_\_

--

Dwg #: \_\_\_\_\_ Pitch: \_\_\_\_\_ # of Pieces: \_\_\_\_\_

Description: \_\_\_\_\_

Hems:  Open  Closed  Slightly Open

**Please provide a drawing for each flashing with precise measurements and angles**

**Fax to: 503-581-6877**

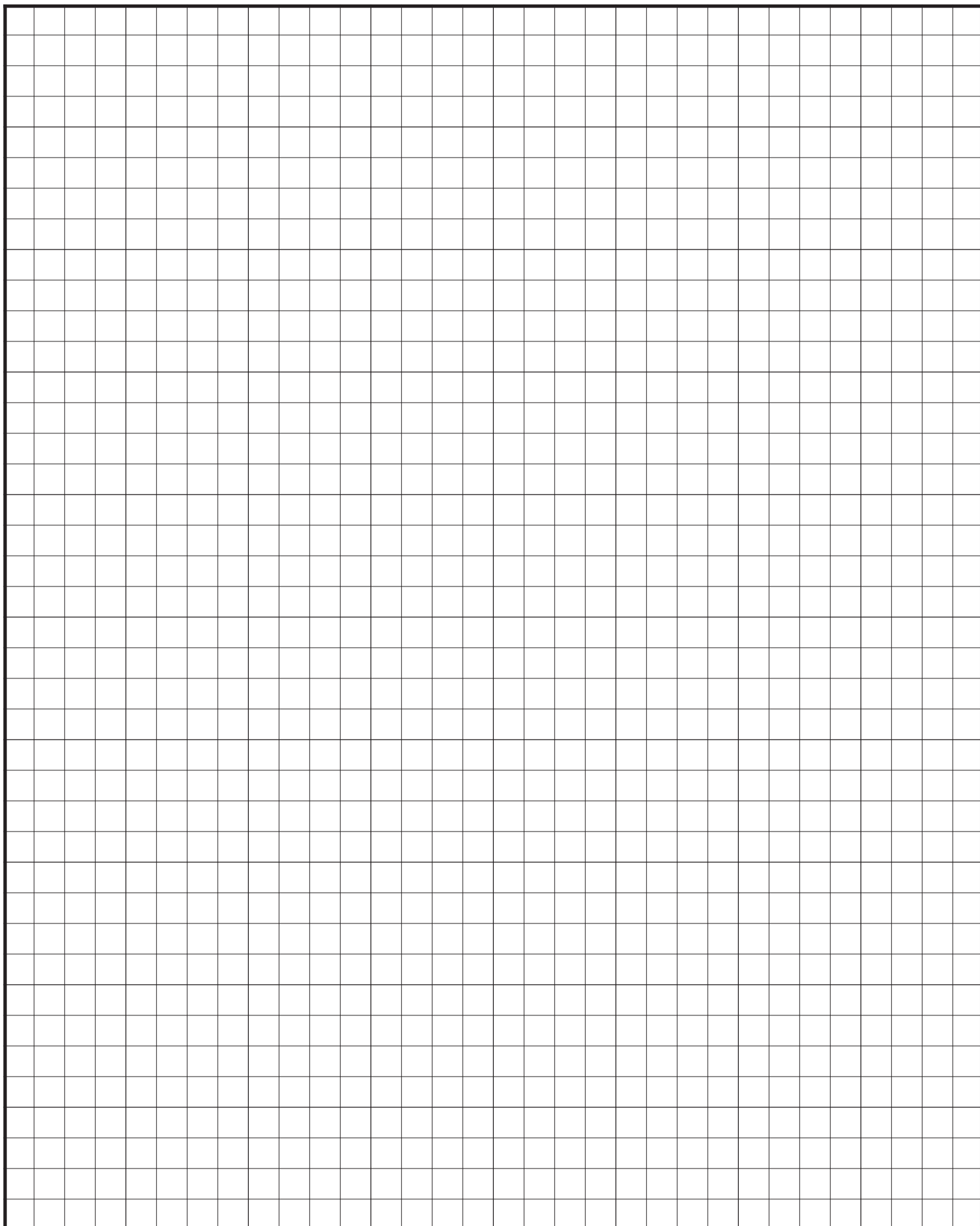







**TAYLOR**

---

**METAL PRODUCTS**

---

**QUALITY PRODUCTS**  
**EXCEPTIONAL SERVICE**

---

**SALEM BRANCH**

4566 Ridge Dr. NE  
Salem, OR 97301

Office: 503-581-8338  
Toll Free: 1-800-574-1388  
Fax: 503-581-6877

**SACRAMENTO BRANCH**

5711 Perrin Ave  
McClellan, CA 95652

Office: 916-318-8844  
Toll Free: 1-800-574-1388  
Fax: 916-993-4123

**SPOKANE BRANCH**

1010 N Nelson St.,  
Spokane, WA 99202  
[www.go-rsp.com](http://www.go-rsp.com)

Office: 509-535-8667  
Toll Free: 800-238-4057  
Fax: 509-535-8682

**AUBURN BRANCH**

2601 C St SW,  
Auburn, WA 98001

Office: 206-900-9923  
Toll Free: 1-800-574-1388  
Fax: 253-804-3545

**RIVERSIDE BRANCH**

4880 Felspar St.  
Riverside, CA 92509

Office: 323-407-7457  
Toll Free: 1-877-504-1594